

8. AIR CONDITIONER AND HEATER

1) CLEAN AND REPLACE OF THE CIRCULATION FILTER

※ **Always stop the engine before servicing.**

- (1) Remove the screw (1) and cover (2) on the seat base.
- (2) Remove the circulation filter (3).

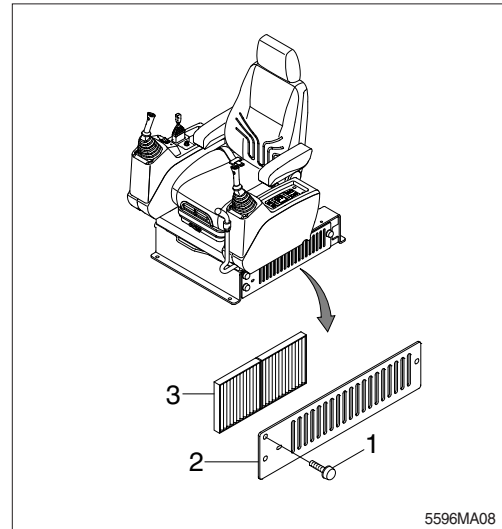

- (4) Clean the filter using a pressurized air (Below 2 kgf/cm², 28psi).

△ **When using pressurized air, be sure to wear safety glasses.**

- (5) Inspect the filter after cleaning. If it is damaged or badly contaminated, use a new filter.

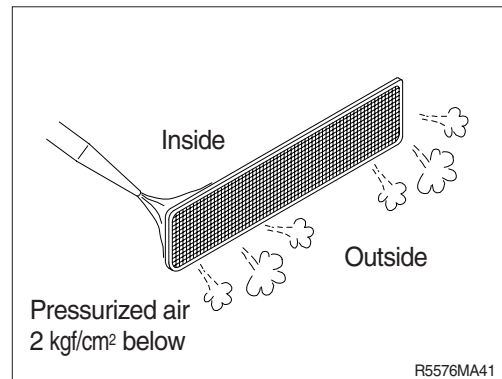

2) CLEAN AND REPLACE OF THE RECIRCULATION FILTER

※ **Always stop the engine before servicing.**

- (1) Remove the screw (1), cover (2) and pad (3).
- (2) Remove the recirculation filter (4).

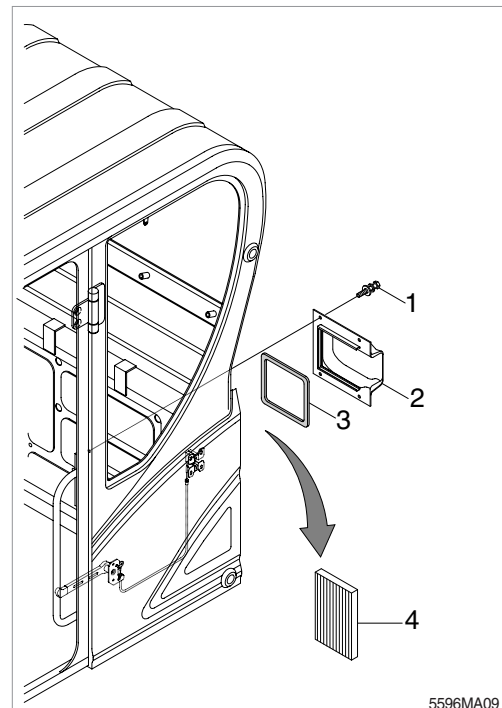

- (3) Clean the recirculation filter using a pressurizes are (Below 2 kgf/cm², 28psi) or washing with water.

△

When using pressurized air, be sure to wear safety glasses.

- (4) Inspect the filter after cleaning. If it is damaged or badly contaminated, use a new filter.

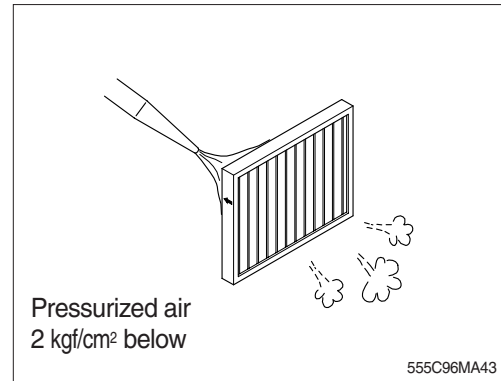

3) PRECAUTIONS FOR USING AIR CONDITIONER

- (1) When using the air conditioner for a long time, open the window once every one hour.
- (2) Be careful not to overcool the cab.
- (3) The cab is properly cooled if the operator feels cool when entering there from outside (about 5°C lower than the outside temperature).
- (4) When cooling, change air occasionally.

4) CHECK DURING SEASON

Ask the service center for replenishment of refrigerant or other maintenance service so that the cooling performance is not damaged.

5) CHECK DURING OFF-SEASON

Operate the air conditioner 2 or 3 times a month (each for a few minutes) to avoid loss of oil film in the compressor.