

4. LOADING THE MACHINE

- 1) Load and unload the machine on a flat ground.
- 2) Use the gangplank with sufficient length, width, thickness and gradient.
- 3) Place block tires of the truck and the trailer not to move the trailer.
- 4) Place the swing lock device to the **LOCK** position before fixing the machine at the bed of trailer and confirm if the machine parallels the bed of trailer.
- 5) Drive straight and depress the acceleration pedal slowly on the gangplank with the two speed switch positioned as low speed.

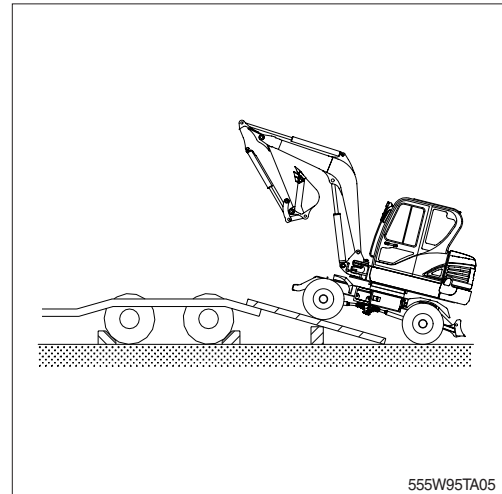

- 6) Do the following after loading the machine to the trailer.
 - (1) Stop loading when the machine is located horizontally with the rear wheel of trailer.

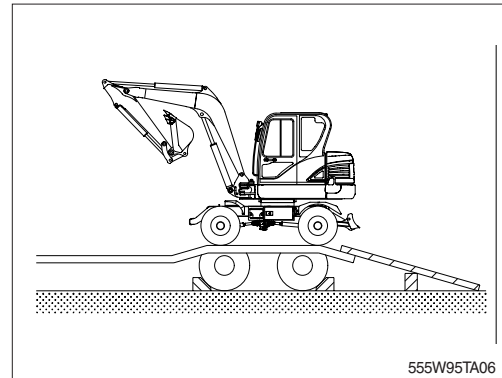

- (2) Place the swing lock device to the **LOCK** position after the swing the machine 180 degree.

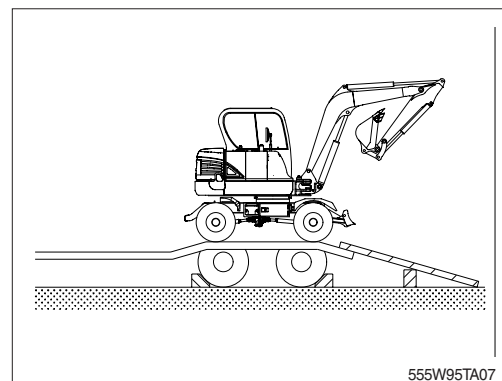

(3) Lower the working equipment gently after the location is determined.

※ **Place rectangular timber under the bucket cylinder to prevent the damage of it during transportation.**

▲ **Be sure to keep the travel speed switch on the low speed while loading and unloading the machine.**

▲ **Avoid using the working equipment for loading and unloading since it will be very dangerous.**

▲ **Do not operate any other device when loading.**

▲ **Be careful on the boundary place of loading plate or trailer as the balance of machine will abruptly be changed on the point.**

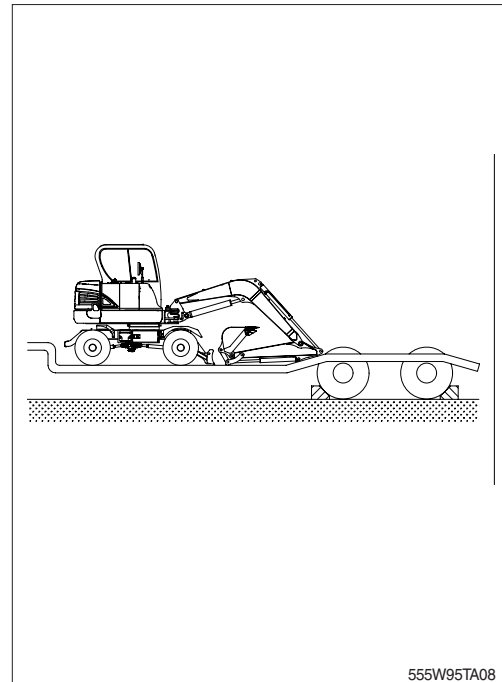

555W95TA08