

### 3. DIMENSION AND WEIGHT

#### 1) Base machine

Mark	Description	Unit	Specification
L	Length	mm (ft-in)	3580 (11' 9")
H	Height	mm (ft-in)	2850 ( 9' 4")
Wd	Width	mm (ft-in)	1925 ( 6' 4")
Wt	Weight	kg (lb)	4760 (10490)

※ With 180 kg (400 lb) counterweight.

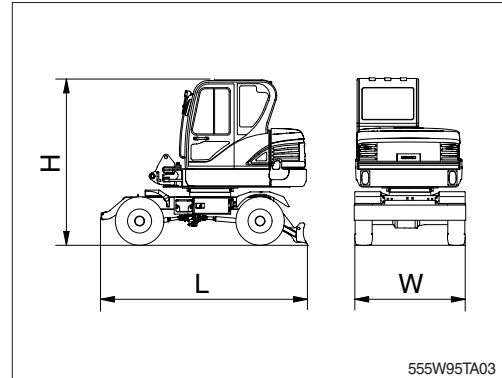

#### 2) Boom assembly

Mark	Description	Unit	Specification
L	Length	mm (ft-in)	3120 (10' 3")
H	Height	mm (ft-in)	1140 ( 3' 9")
Wd	Width	mm (ft-in)	250 ( 0'10")
Wt	Weight	kg (lb)	300 (660)

※ 3.0 m (9'10") boom with arm cylinder (included piping and pins).

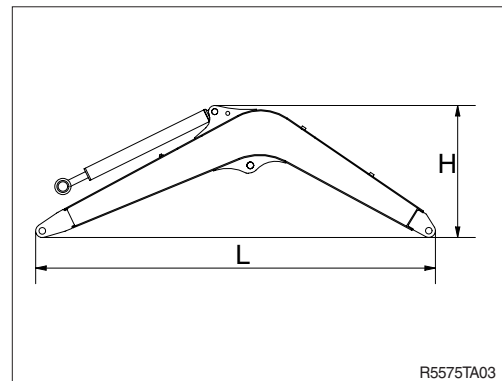

#### 3) Arm assembly

Mark	Description	Unit	Specification
L	Length	mm (ft-in)	2130 ( 6'12")
H	Height	mm (ft-in)	450 ( 1' 6")
Wd	Width	mm (ft-in)	170 ( 0' 7")
Wt	Weight	kg (lb)	205 (450)

※ 1.6 m (5' 3") arm with bucket cylinder (included linkage and pins).

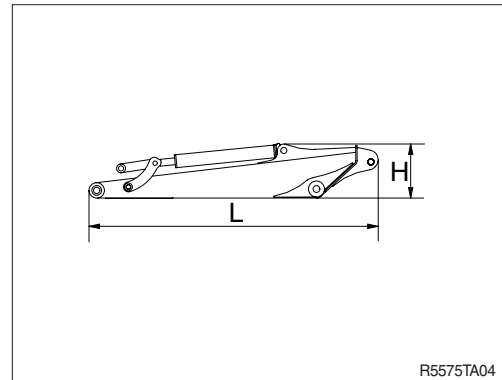

#### 4) Bucket assembly

Mark	Description	Unit	Specification
L	Length	mm (ft-in)	1020 ( 3' 4")
H	Height	mm (ft-in)	570 ( 1' 10")
Wd	Width	mm (ft-in)	740 ( 2' 5")
Wt	Weight	kg (lb)	170 (380)

※ 0.18 m<sup>3</sup> (0.24 yd<sup>3</sup>) SAE heaped bucket (Included tooth and side cutters).

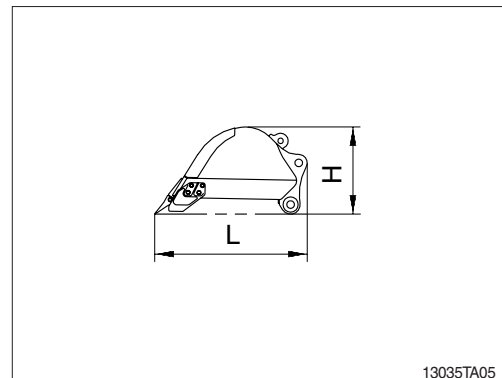

### 5) Boom cylinder

Mark	Description	Unit	Specification
L	Length	mm (ft-in)	1210 ( 3'12")
H	Height	mm (ft-in)	150 ( 0' 6")
Wd	Width	mm (ft-in)	280 ( 0'11")
Wt	Weight	kg (lb)	70 (155)

※ Included piping.

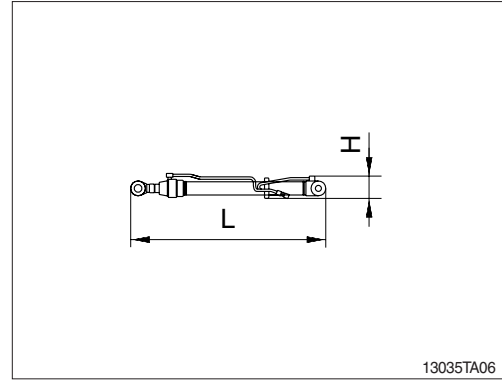

### 6) Cab assembly

Mark	Description	Unit	Specification
L	Length	mm (ft-in)	1650 ( 5' 5")
H	Height	mm (ft-in)	1530 ( 5' 0")
Wd	Width	mm (ft-in)	1060 ( 3' 6")
Wt	Weight	kg (lb)	350 (770)

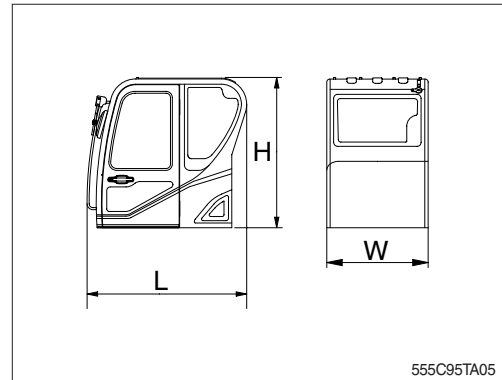

### 7) Counterweight

Mark	Description	Unit	Specification
L	Length	mm (ft-in)	1850 ( 6' 1")
H	Height	mm (ft-in)	420 ( 1' 5")
Wd	Width	mm (ft-in)	645 ( 2' 1")
Wt	Weight	kg (lb)	180 (400)

