

SPECIFICATIONS

1. MAJOR COMPONENTS

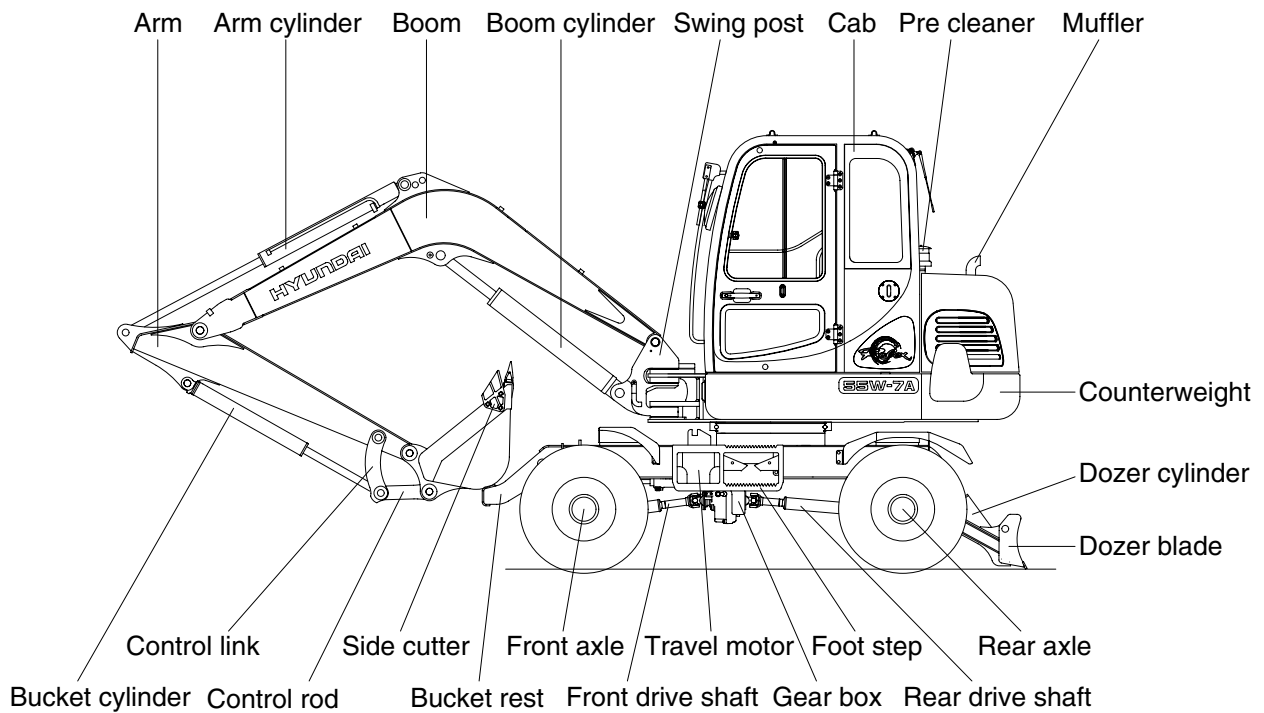
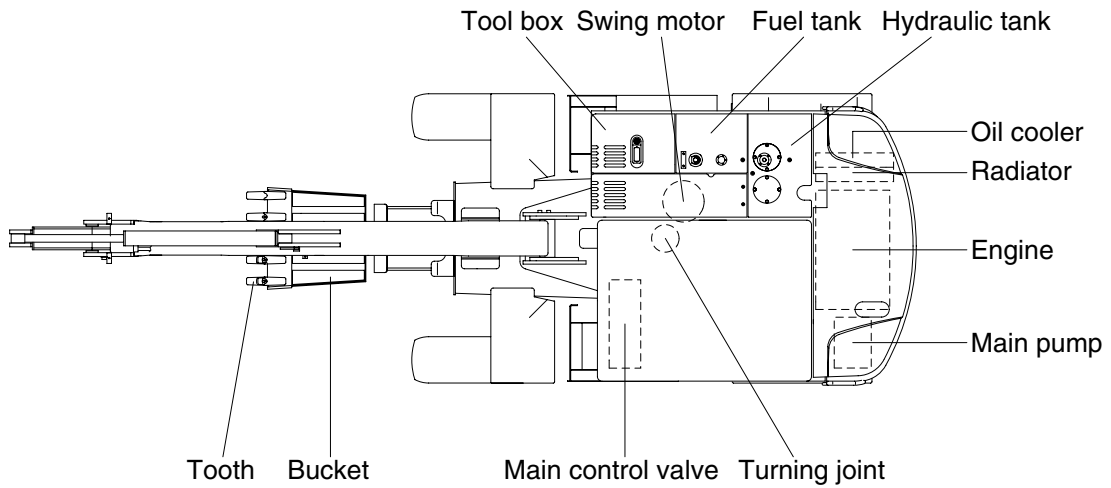

55W7A2SP01