

1. SUGGESTION FOR NEW MACHINE

- 1) It takes about 100 operation hours to enhance its designed performance.
- 2) Operate according to below three steps and avoid excessive operation for the initial 100 hours.

| Service meter | Load |
|-----------------|-----------|
| Until 10 hours | About 60% |
| Until 100 hours | About 80% |
| After 100 hours | 100% |

※ **Excessive operation may deteriorate the potential performance of machine and shorten lifetime of the machine.**

3) Be careful during the initial 100 hours operation

- (1) Check daily for the level and leakage of coolant, engine oil, hydraulic oil and fuel.
- (2) Check regularly the lubrication and fill grease daily all lubrication points.
- (3) Tighten bolts.
- (4) Warm up the machine fully before operation.
- (5) Check the gauges occasionally during the operation.
- (6) Check if the machine is operating normally during operation.

4) Replace followings after initial 50 hours of operation

| Checking items | Service |
|-------------------------------------|---------|
| Engine oil | Replace |
| Engine oil filter element | |
| Hydraulic oil return filter element | |
| Line filter element | |
| Fuel filter | |

Avoid excessive operation for initial 100 hours

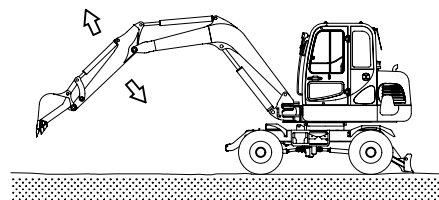

55W74OP01

2. CHECK BEFORE STARTING THE ENGINE

- 1) Look around the machine and under the machine to check for loosen nut or bolts, collection of dirt, or leakage of oil, fuel or coolant and check the condition of the work equipment and hydraulic system. Check also loosen wiring, and collection of dust at places which reach high temperature.
※ **Refer to the daily check on the chapter 6, maintenance.**
- 2) After checking air pressure of tire, make sure that around the machine is clear.
- 3) Adjust seat to fit the contours of the operator's body for the pleasant operation.
- 4) Adjust the rear view mirror.

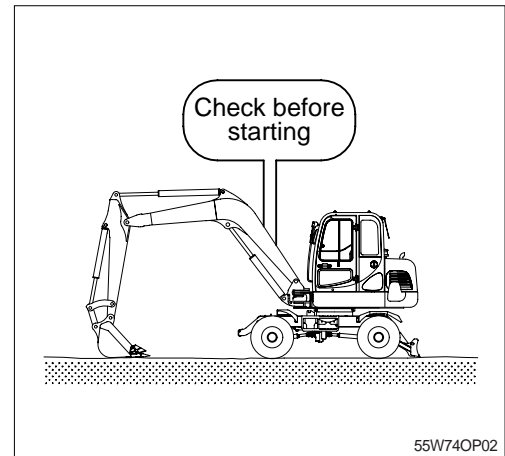

3. STARTING AND STOP THE ENGINE

1) CHECK INDICATOR LIGHTS

- (1) Check if all the operating lever is on the neutral position.
- (2) Turn the starting switch to the ON position, and check following.
 - ① If all the lamps light ON and buzzer sounding for 6 seconds.
 - ② Only below lamps will light ON and all the other lights will turn OFF after 2 seconds.
 - Battery charging warning lamp(2)
 - Engine oil pressure warning lamp(1)
 - ③ The preheat pilot lamp(3) will light ON when the coolant temperature is below 10°C.
 - ④ The warming up pilot lamp(4) will light ON when the coolant temperature is below 30°C.

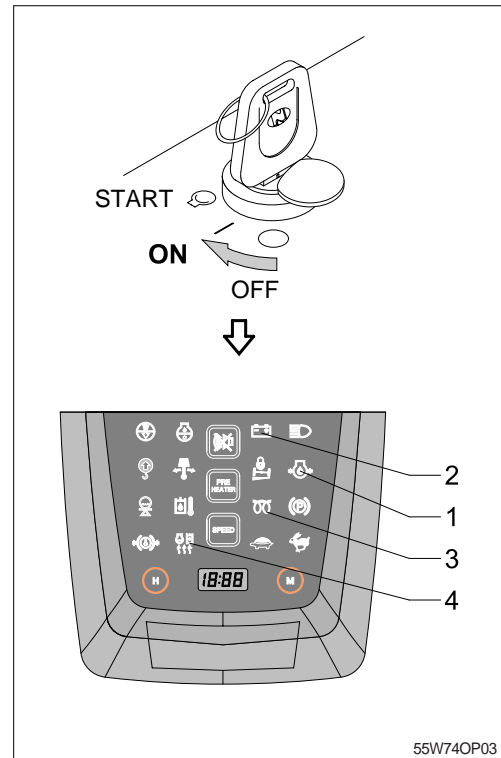

2) STARTING ENGINE

- ※ Sound horn to warn surroundings after checking if there are obstacles in the area.
- ※ Replace the engine oil and fuel referring to recommended oils at page 2-10.
- ※ Fill anti-freeze solution to the coolant as required.

- (1) Check if all levers are on the neutral position.
- (2) Turn the starting switch to ON position.
- (3) Check if the preheat pilot lamp(1) is turned ON.
 - ※ When the preheat pilot lamp is turned ON, the preheating function is actuated within 15 seconds.
 - ※ After the preheat pilot lamp is turned OFF, engine start within 10 seconds.
- (4) Start engine by turning the starting switch to the START position.
- (5) Release the starting switch immediately after starting engine to avoid possible damage to the starting motor.
 - ※ If the engine is started before the preheat pilot lamp goes OFF, it keeps the lamp ON within 15 seconds even after the engine is started.

- ※ If the engine does not start, the start switch turn ON position and press the preheat switch (2) for preheating. After the preheating, start the engine again.
- ※ If the engine does not start, allow the starter to cool for 10~20 seconds before attempting to start the engine again. At the cold, allow 2 minute before attempting to start the engine again.

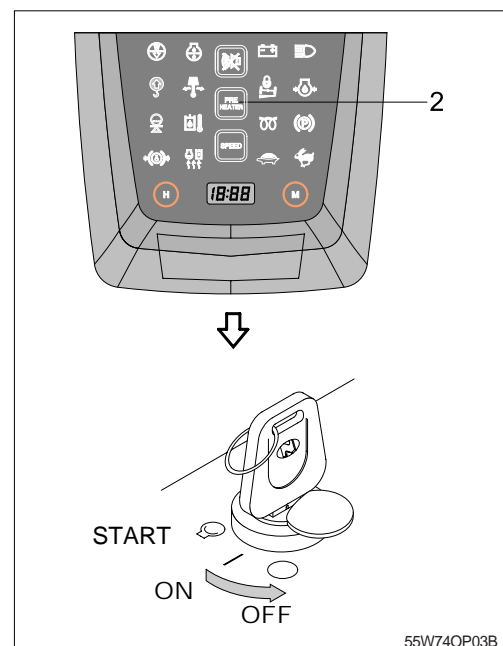

3) INSPECTION AFTER ENGINE START

Inspect and confirm the following after engine starts.

- (1) Is the level gauge of hydraulic oil tank in the normal level?
- (2) Are there leakages of oil or water?
- (3) Are all the warning lamps OFF(2~10)?
- (4) Is the indicator of engine coolant temperature gauge(1) in the normal zone?
- (5) Is the engine sound and the color of exhaust gas normal?
- (6) Are the sound and vibration normal?

- ※ Do not increase engine speed quickly after starting, it can damage engine or turbocharger.
- ※ If there are problems in the control panel, stop the engine immediately and correct problem as required.

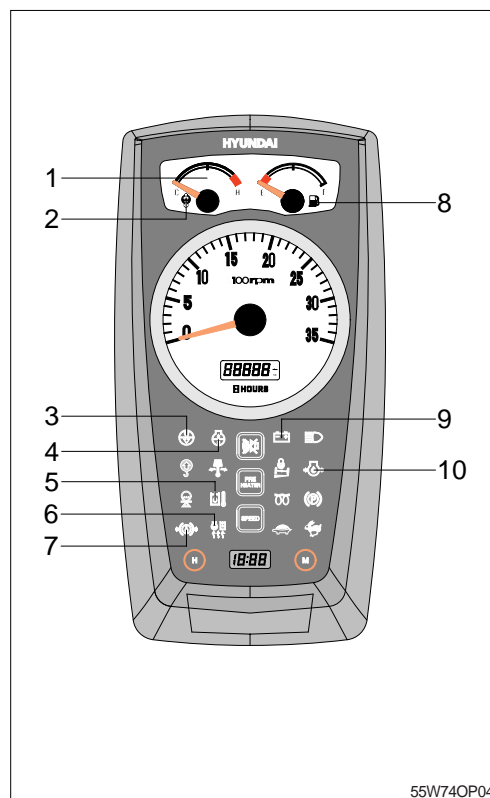

55W74OP04

4) WARMING-UP OPERATION

- ※ The most suitable temperature for the hydraulic oil is about 50° C (122° F). It can cause serious trouble in the hydraulic system by sudden operation when the hydraulic oil temperature is below 25° C (77° F). Then temperature must be raised to at least 25° C (77° F) before starting work.

- (1) Run the engine at low idling for 5 minutes.
- (2) Speed up the idling and run the engine at mid-range speed.
- (3) Operate bucket lever for 5 minutes.
 - ※ Do not operate anything except bucket lever.
- (4) Run the engine at the high speed and operate the bucket lever and arm lever for 5-10 minutes.
 - ※ Operate only the bucket lever and arm lever.
- (5) This warming-up operation will be completed by operation of all cylinders several times, and operation of swing and traveling.
 - ※ Increase the warming-up operation during winter.

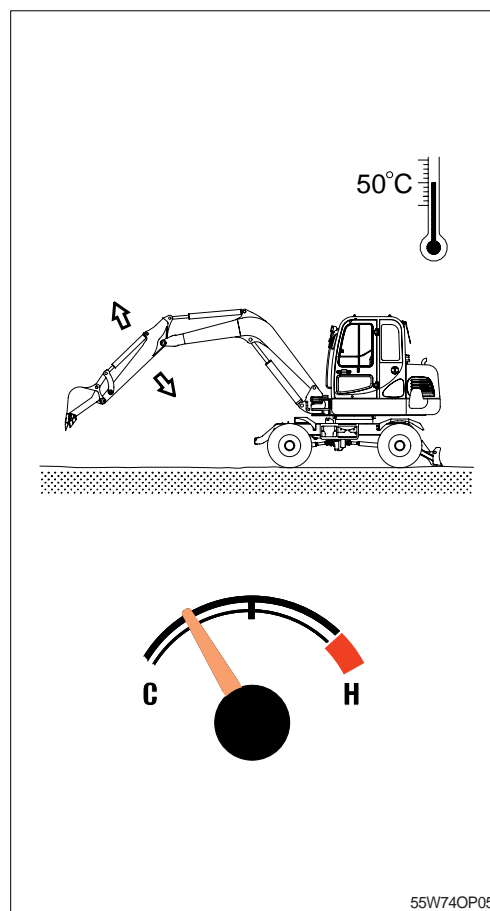

55W74OP05

5) TO STOP THE ENGINE

- ※ If the engine is abruptly stopped before it has cooled down, engine life may be greatly shortened. Consequently, do not abruptly stop the engine apart from an emergency.
- ※ In particular if the engine has overheated, do not abruptly stop it but run it at medium speed to allow it to cool gradually, then stop it.

- (1) Place the forward/backward lever in the neutral.
- (2) Down the bucket and dozer blade on the ground then put all the levers in the neutral position.
- (3) Put the parking switch in the parking position.
- (4) Run the engine at low idling speed for about 5 minutes.
- (5) Return the key of starting switch to the OFF position.
- (6) Remove the key to prevent other people using the machine and LOCK safety lever.
- (7) Lock the cab door.

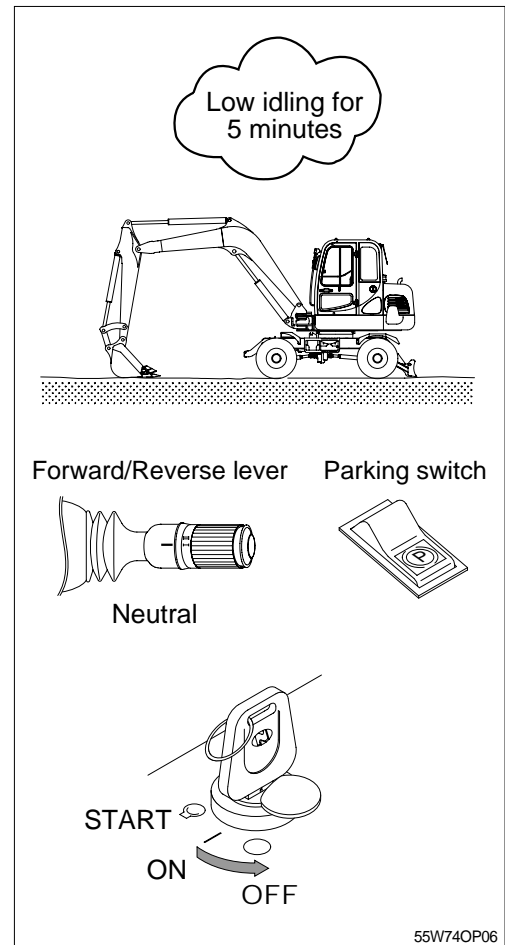

4. OPERATION OF WORKING DEVICE

※ **Confirm the operation of control lever and working device.**

- 1) Left control lever controls arm and swing.
- 2) Right control lever controls boom and bucket.
- 3) When you release the control lever, control lever returns to neutral position automatically.

※ **When operating swing, consider the swing distance by inertia.**

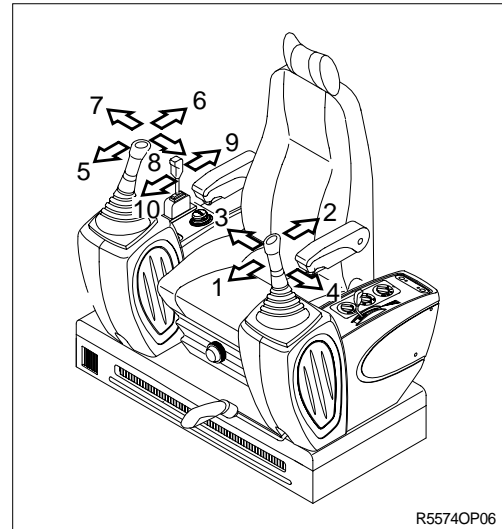

※ **Left control lever**

- 1 Arm roll-out
- 2 Arm roll-in
- 3 Swing right
- 4 Swing left
- 3' Boom right(Boom offset switch selected)
- 4' Boom left(Boom offset switch selected)

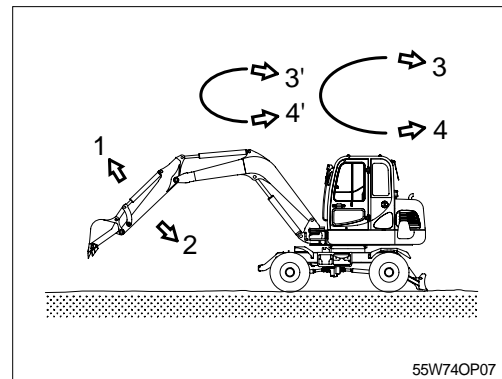

※ **Right control lever**

- 5 Boom lower
- 6 Boom raise
- 7 Bucket roll-out
- 8 Bucket roll-in

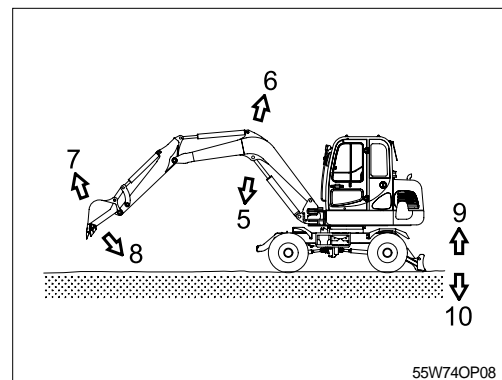

※ **Dozer control lever**

- 9 Dozer blade up
- 10 Dozer blade down

5. TRAVELING OF THE MACHINE

1) BASIC OPERATION

(1) Traveling position

It is the position which the dozer and rear axle is in the rear and the working device is forward.

- ▲ **Travel directions will be reversed if lower structure is positioned with dozer in front.**

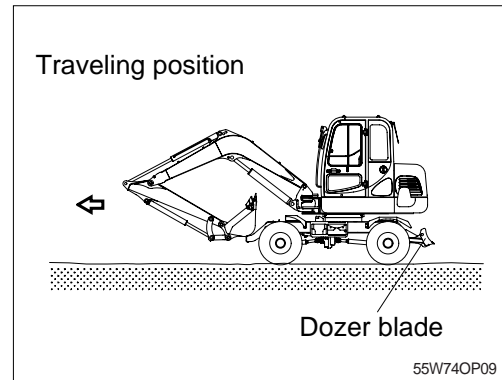

(2) Traveling operation

When warm-up operation is completed after the engine is started, move the machine according to the following procedure.

- ① Set the swing lock pin to release position.
 - ② Release the safety lever.
 - ③ Put the parking switch in the traveling position.
 - ④ Lift up the dozer blade.
 - ⑤ Select traveling direction.
 - ⑥ Place the travel speed switch in low speed.
 - ⑦ Press gently the acceleration pedal to move the machine.
- ※ **When speed up on a slope, a noise for valve of travel motor may occur. It is not out of order in machine but peculiar sound.**
 - ※ **Be sure that the brake works normally on the safe place before fast traveling.**

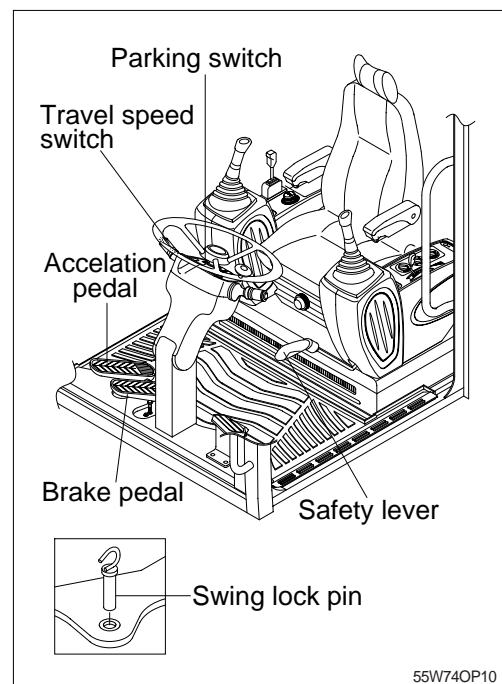

(3) Changing speed

If you want to change the speed, select the travel speed switch desired position.

- ※ **In case of changing the travel speed, be sure to stop the machine completely.**
- ▲ **Do not start the machine abruptly after changing speed.**

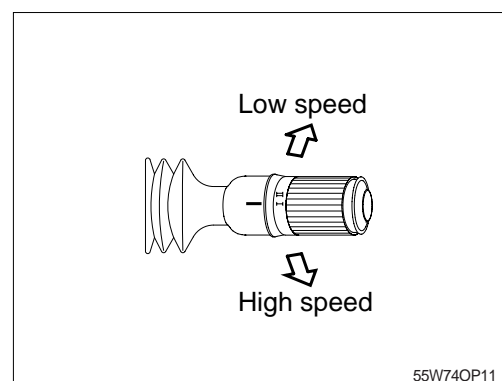

(4) Changing direction(Forward/Reverse)

- ① Be sure to stop the machine when changing the direction forward or backward while traveling.
 - ② Put the levers in the desired position to change direction.
- ※ When changing direction, check beforehand there is no obstacle in the direction you will be headed.
 - ※ It could be cause of machine failure to change the direction forward or backward while traveling.

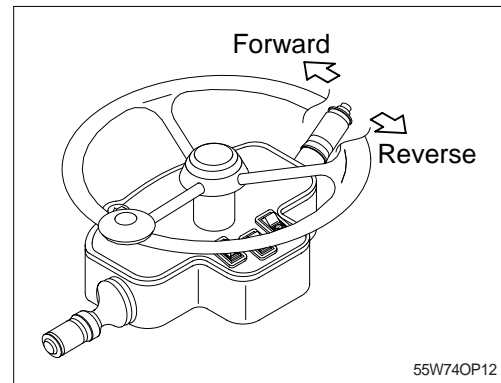

(5) Turning the machine

- ① Turn the machine by moving the steering wheel into the desired direction.
 - ② You can turn the machine to the left or right.
- ※ Do not turn the machine abruptly when traveling at high speed and avoid turn on a slope.
- ▲ Steering does not function with engine OFF.

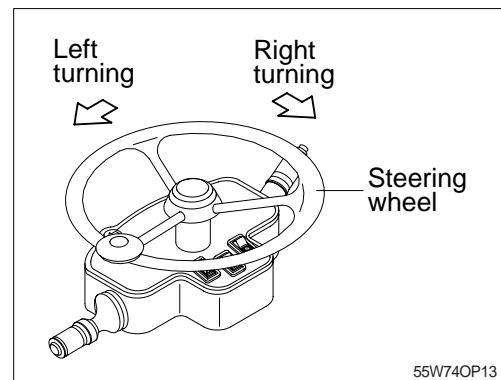

(6) Precautions when driving

The operators must be familiar with the following precautions including general safety hints.

- ① If the warning lamp lights up on the cluster, stop the machine immediately and check carefully whether the relevant parts are out of order or not.
- ② Do not allow the engine to run at overload.
- ③ Stop the engine and check as soon as finding out abnormal noise or smell.
- ④ Check the gauges frequently.
- ⑤ Do not allow passengers or riders on the machine while it is running or in operation.
- ⑥ Never get on or off the machine while it is moving.

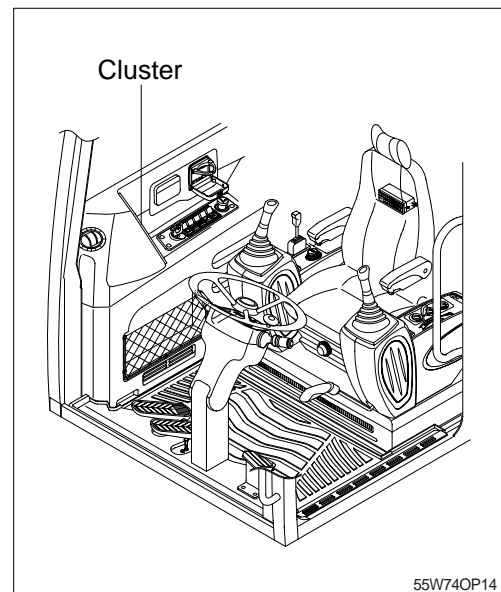

2) TRAVELING ON A SLOPE

- (1) Never travel down a slope in neutral.
 - (2) Lower the bucket 20 to 30cm(1ft) to the ground so that it can be used as a brake in an emergency.
 - (3) If the machine starts to slide or loses stability, lower the bucket immediately and brake the machine.
 - (4) When parking on a slope, use the bucket as a brake and place blocks behind the tires to prevent sliding.
- ※ **Machine cannot travel effectively on a slope when the oil temperature is low. Do the warming-up operation when it is going to travel on a slope.**
 - ※ **Be careful when working on slopes. It may cause the machine to lose its balance and turn over.**

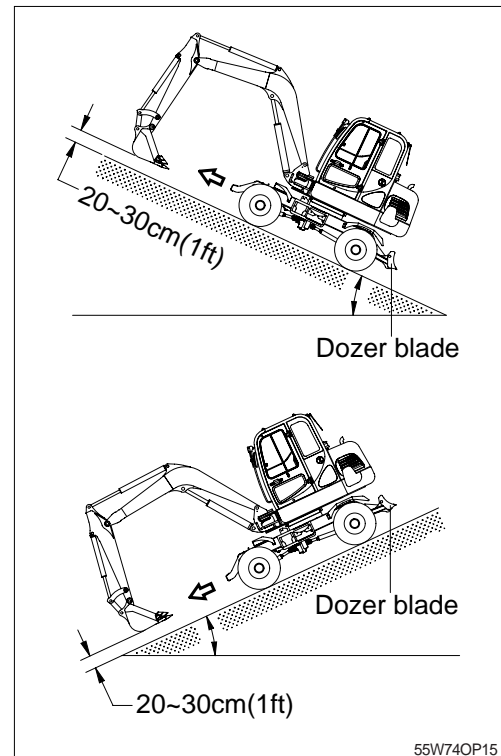

3) PARKING THE MACHINE

To park the machine, keep the steps below.

- (1) Release the acceleration pedal slowly.
 - (2) Depress the brake pedal.
 - (3) Place the forward/backward lever in the neutral.
 - (4) Put the parking switch in the parking position and release the brake pedal.
 - (5) Lower the bucket and dozer blade to the ground.
 - (6) Stop the engine, place the start key switch in the OFF and remove the key.
 - (7) Lock the swing lock pin and the cab door.
- ※ **Whenever parking on a slope, always block the tires after lowering the bucket to the ground.**
 - ※ **Contain the swing lock pin in the tool box to avoid loss.**

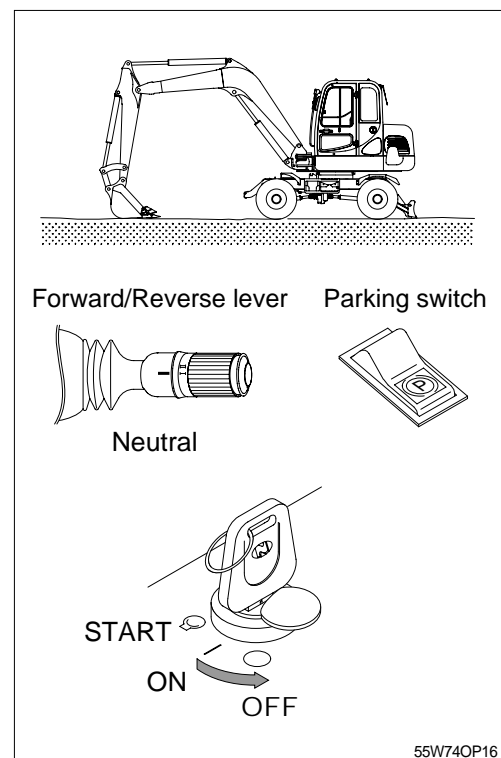

4) TOWING THE MACHINE

Except for an emergency, do not tow this machine.
If it is inevitable to tow this machine, observe the following.

(1) General

- ① Parking brake cylinder of the machine is operated by the spring force and released by hydraulic pressure.

If the engine does not operate, the brake will be operated to stop the machine.

- ② When the machine is towed move it for a repair to nearby place at the low speed.

Transport it on a trailer, if it has to be moved for a long distance.

- ③ When the steering device and the brake of the machine to be towed can not be operated, transport by trailer.

▲ Injury or death could result if a disabled machine is towed incorrectly.

▲ If your machine is towed by another machine, ALWAYS use a wire rope with a sufficient towing capacity.

▲ NEVER allow a disabled machine to be towed on a slope.

▲ When connecting up a towing machine, do not let anyone enter the area between the towing machine and the equipment being towed.

▲ Set the towing machine and the towing connection of the equipment being towed in a straight line when connecting it.

▲ Never tow machine using a light-duty towing hook.

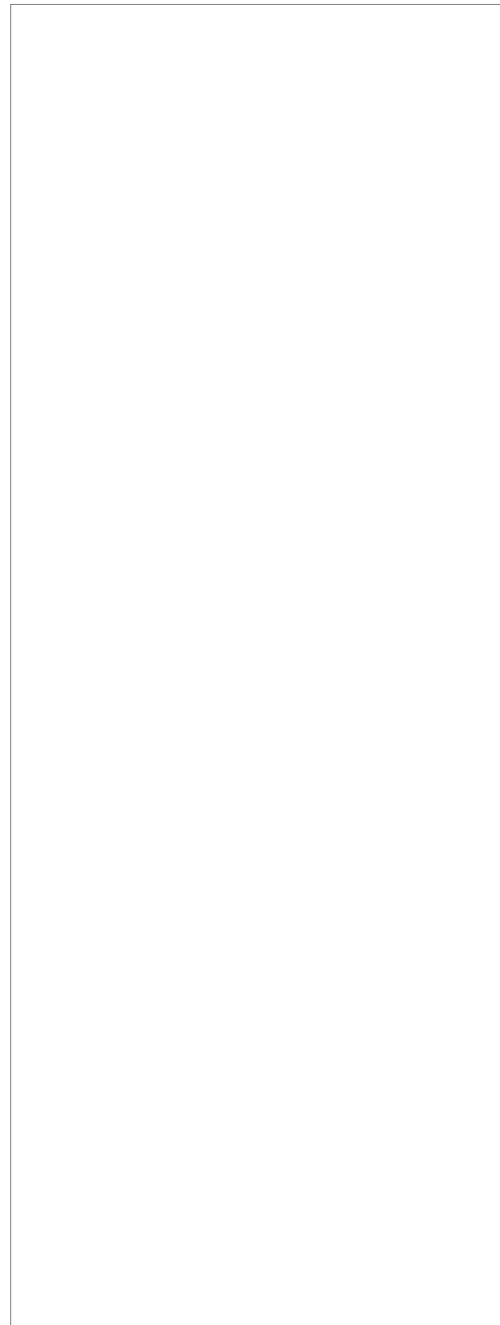

(2) Towing the machine

- ① When moving the machine or in case of an emergency towing, the power flow between final drive(Spur gear drive) and travel motor will be interrupted.
 - ② For this purpose, loosen the locking screw and remove the spacer of rear axle.
 - ③ Tighten locking screw both side.
- ▲ Both sides of locking screw must be tightened more and more by turns.**

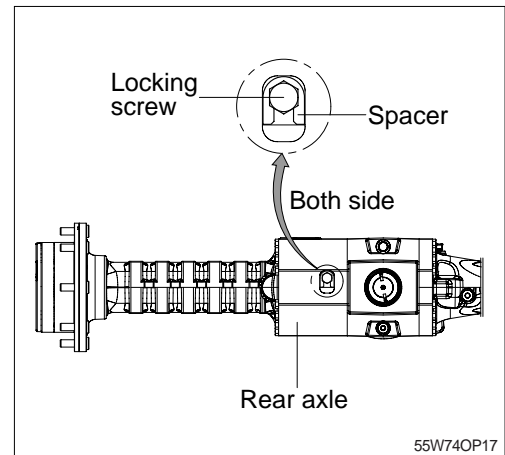

- ④ Turn start key ON position, place parking switch at traveling position to release brake.

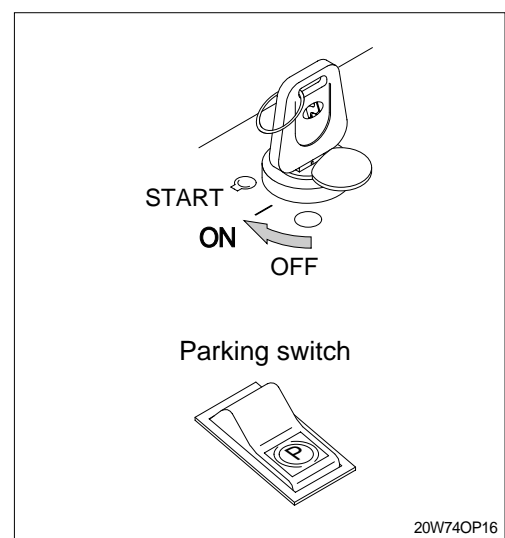

5) PRECAUTIONS FOR OPERATION

(1) Permissible water depth

- ① Do not immerse the machine in water by more than the permissible depth(Axle center).
- ② For parts that have been immersed in water for a long time, pump in grease until the old grease comes out from the bearings.

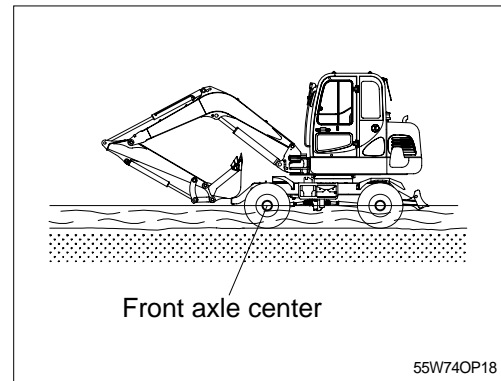

(2) When the brake does not operate

- ① If the machine does not stop even though the brake pedal is applied, use the parking brake to activate the emergency brake by parking switch.
 - ※ After using the parking brake as an emergency brake, ask Hyundai dealer to check complete brake system.
- ▲ Never use emergency brake, except when the service brake fails.

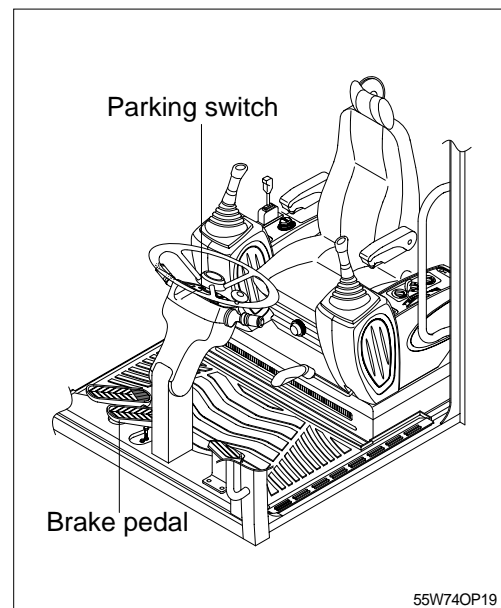

6. EFFICIENT WORKING METHOD

- 1) Do the digging work by arm.

Use the pulling force of arm for digging and use together with the digging force of the bucket if necessary.

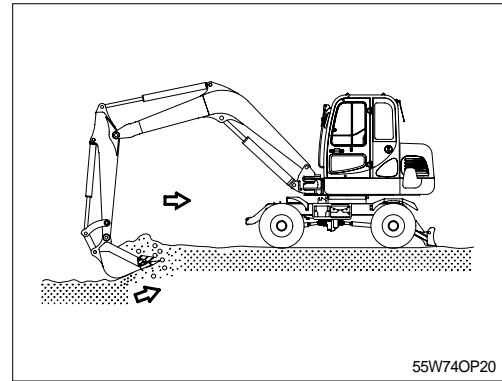

- 2) When lowering and raising the boom operate softly for the beginning and the end.

In particular, sudden stops while lowering the boom may cause damage to the machine.

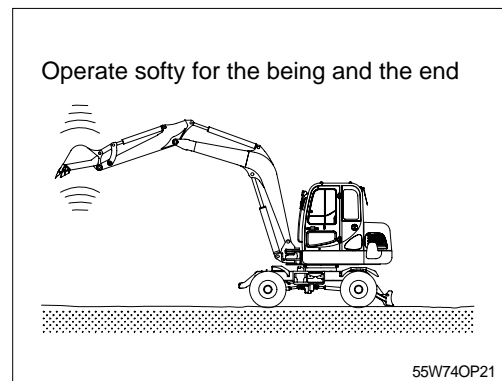

- 3) The digging resistance and wearing of tooth can be reduced by putting the end of bucket tooth to the digging direction.

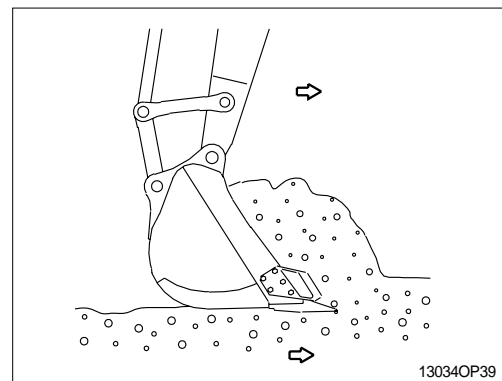

- 4) Set the tracks parallel to the line of the ditch to be excavated when digging ditch. Do not swing while digging.

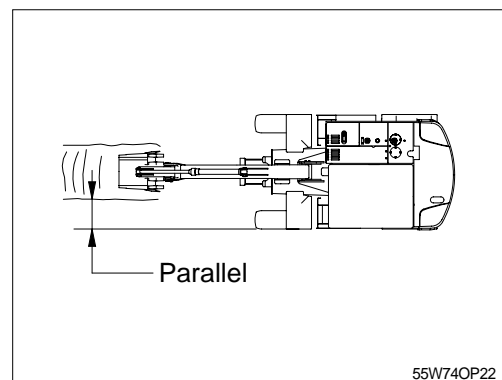

- 5) Dig slowly with keeping the angle of boom and arm, 90-110 degree when maximum digging force is required.

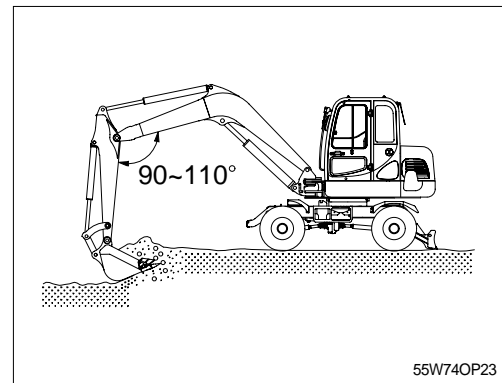

- 6) Operate leaving a small safety margin of cylinder stroke to prevent damage of cylinder when working with the machine.

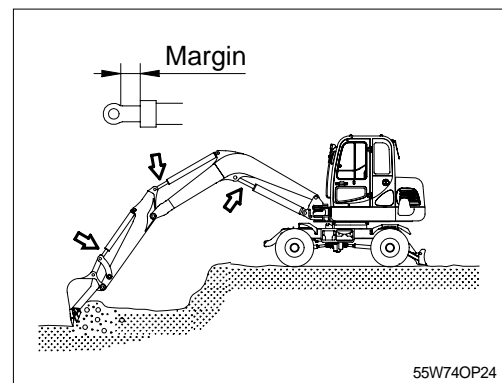

- 7) Keep the bucket to the dumping position and the arm horizontal when dumping the soil from the bucket.
Operate bucket lever 2 or 3 times when hard to dump.

※ Do not use the impact of bucket tooth when dumping.

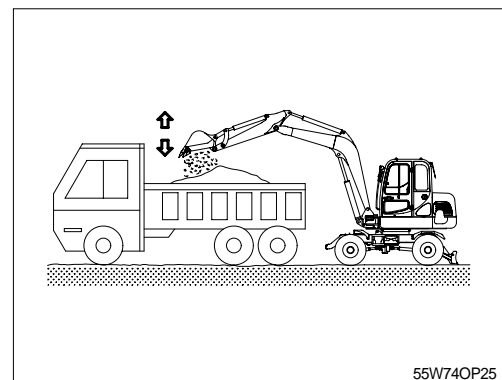

- 8) Operate stop of swing considering the swing slip distance is created by inertia after neutralizing the swing lever.

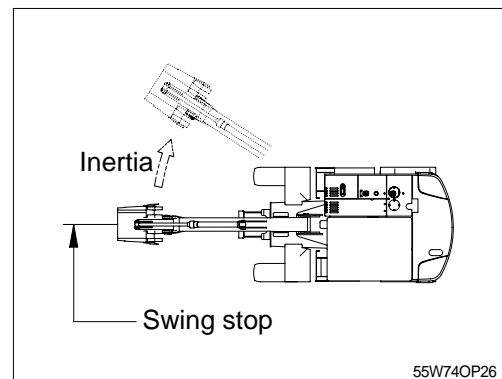

- 9) Do not use the dropping force of the work equipment for digging.
The machine can be damaged by the impact.

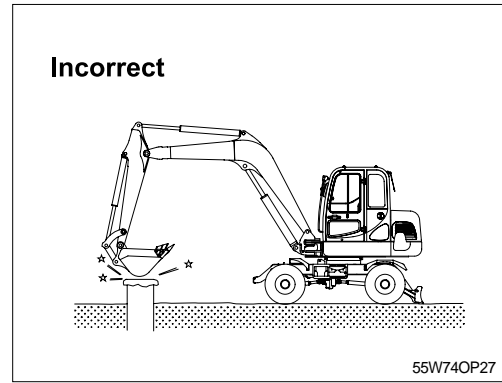

- 10) Do not use the bucket to crack hard objects like concrete or rocks.
This may break a tooth or pin, or bend boom.

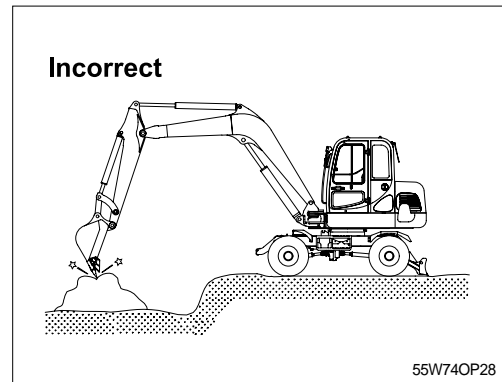

- 11) Do not use the dropping force of the machine for digging.

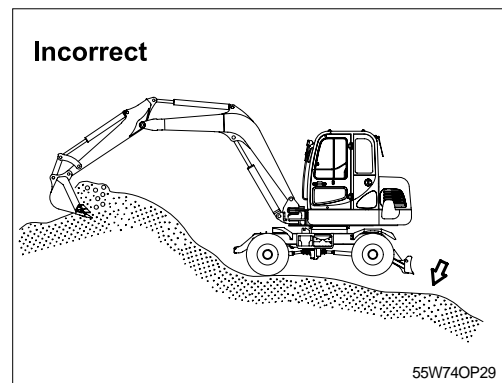

12) NEVER CARRY OUT EXCESSIVE OPERATIONS

Operation exceeding machine performance may result in accident or failure.

Carry out lifting operation within specified load limit.

Never carry out operations which may damage the machine such as overload or over-impact-load.

Never travel while carrying a load.

In case you need installing over load warning device for object handling procedure, please contact Hyundai distributor.

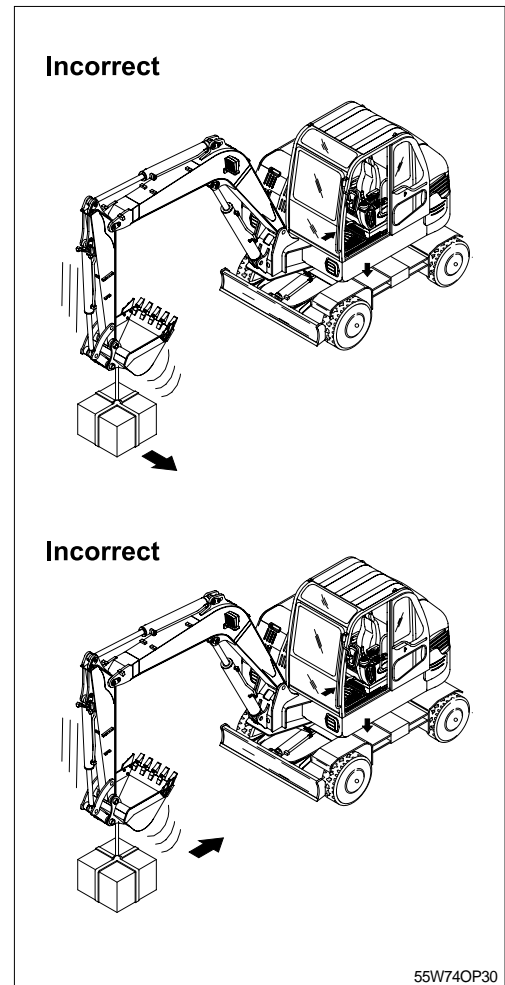

13) BUCKET WITH HOOK

When carrying out lifting work, the special lifting hook is necessary.

The following operations are prohibited.

- Lifting loads with a wire rope fitted around the bucket teeth.
- Lifting loads with the wire rope wrapped directly around the boom or arm.

When performing lifting operation, securely hook the wire rope onto the special lifting hook.

When performing lifting operation, never raise or lower a person.

Due to the possible danger of the load falling or of collision with the load, no persons shall be allowed in the working area.

Before performing lifting operation, designate an operation supervisor.

Always execute operation according to his instructions.

- Execute operating methods and procedures under his direction.
- Select a person responsible for signaling. Operate only on signals given by such person.

Never leave the operator's seat while lifting a load.

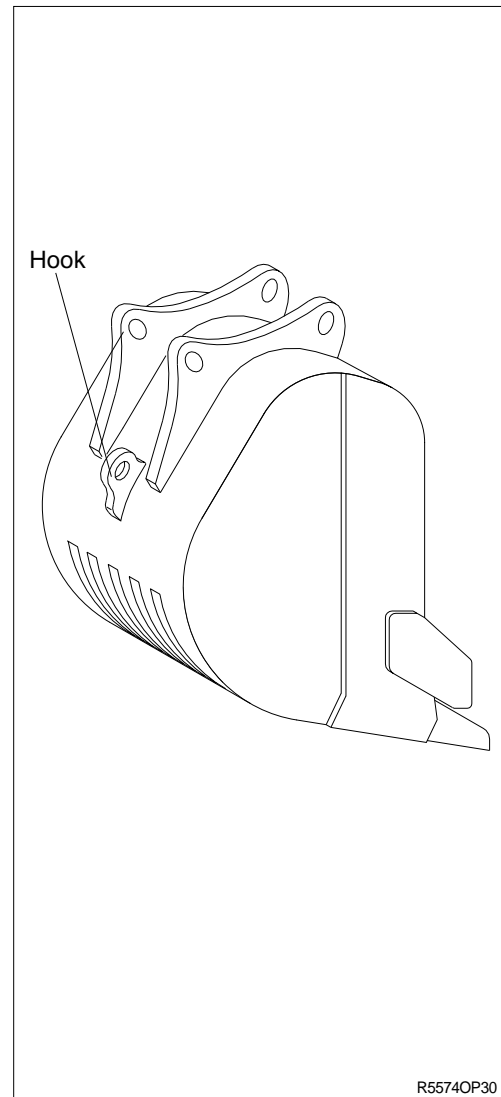

7. OPERATION IN THE SPECIAL WORK SITES

1) OPERATION THE MACHINE IN A COLD WEATHER

- (1) Use proper engine oil and fuel for the weather.
- (2) Fill the required amount of antifreeze in the coolant.
- (3) Refer to the starting engine in cold weather.
Start the engine and extend the warming up operation.
- (4) Be sure to open the heater cock when using the heater.
- (5) Always keep the battery completely charged.
※ **Discharged batteries will freeze more easily than fully charged.**
- (6) Clean the machine and park on the wood plates.

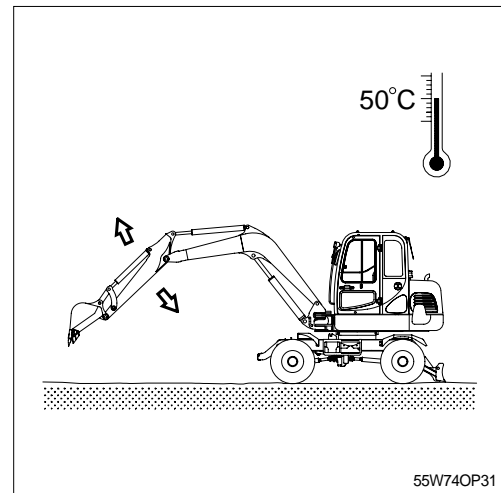

2) OPERATION IN SANDY OR DUSTY WORK SITES

- (1) Inspect air cleaner element frequently. Clean or replace element more frequently, if warning lamp comes ON and buzzer sounds simultaneously, regardless of inspection period.
※ **Replace the inner and outer element after 6 times of cleaning.**
- (2) Inspect radiator frequently, and keep cooling fins clean.
- (3) Prevent sand or dust from getting into fuel tank and hydraulic tank during refilling.
- (4) Prevent sand or dust from penetrating into hydraulic circuit by tightly closing breather cap of hydraulic oil tank. Replace hydraulic oil filter frequently.
- (5) Keep all lubricated part, such as pins and bushings, clean at all times.
- (6) If the air conditioner and heater filters clogged, the heating or cooling capacity will drop. Clean or replace the filter element more frequently.

3) SEA SHORE OPERATION

- (1) Prevent ingress of salt by securely tightening plugs, cocks and bolts of each part.
- (2) Wash machine after operation to remove salt residue.
Pay special attention to electrical parts and hydraulic cylinders to prevent corrosion.
- (3) Inspection and lubrication must be carried out more frequently.
Supply sufficient grease to replace all old grease in bearings which have been submerged in water for a long time.

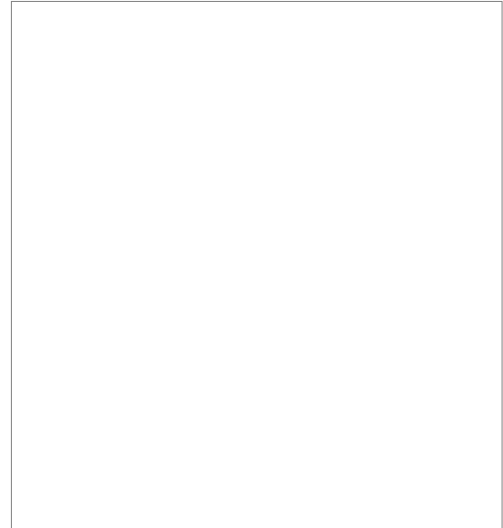

8. NORMAL OPERATION OF EXCAVATOR

Followings may occur during operation due to the nature of a hydraulic excavator.

- 1) When rolling in the arm, the roll-in movement stop momentary at point **X** in the picture shown, then recovers speed again after passing point **X**.
The reason for this phenomenon is that movement by the arm weight is faster than the speed of oil flow into the cylinder.
- 2) When lowering the boom, one may hear continuous sound.
This is caused by oil flow in the valve.
- 3) Overloaded movement will produce sound caused by the relief valves, which are for the protection of the hydraulic systems.
- 4) When the machine is started swing or stopped, a noise near the swing motor may be heard. The noise is generated when the brake valve relieves.

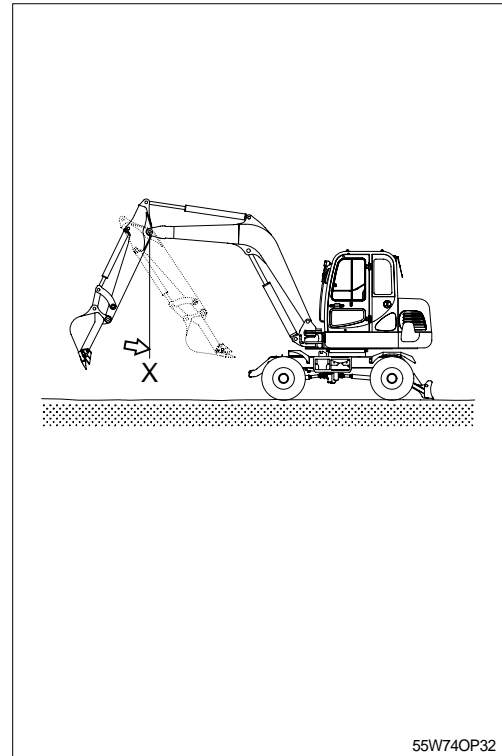

9. ATTACHMENT LOWERING (When engine is stopped)

1) On machines equipped with an accumulator, for a short time (within 2 minutes) after the engine is stopped, the attachment will lower under its own weight when the attachment control lever is shifted to LOWER. That happens only starting switch ON position and safety lever UNLOCK position. After the engine is stopped, set the safety lever to the LOCK position.

▲ Be sure no one is under or near the attachment before lowering the boom.

2) The accumulator is filled with high-pressure nitrogen gas, and it is extremely dangerous if it is handled in the wrong way. Always observe the following precautions.

▲ Never make any hole in the accumulator expose it to flame or fire.

▲ Do not weld anything to the accumulator.

※ When carrying out disassembly or maintenance of the accumulator, or when disposing of the accumulator, it is necessary to release the gas from the accumulator. A special air bleed valve is necessary for this operation, so please contact your Hyundai distributor.

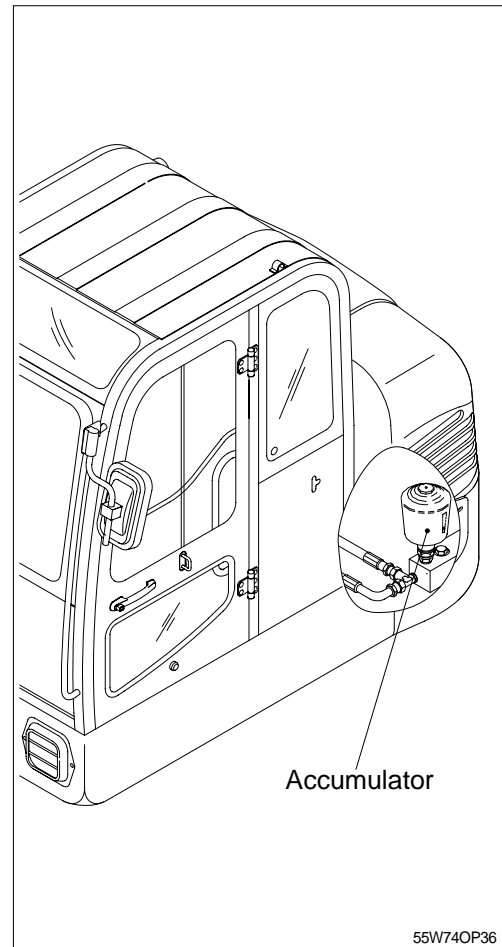

55W740P36

10. STORAGE

Maintain the machine taking care of following to prevent the deterioration of machine when storing the machine for a long time, over 1 month.

1) CLEANING THE MACHINE

Clean the machine and dried.
Grease each lubrication part.

2) LUBRICATION POSITION OF EACH PART

Change all oil.

※ Be particularly careful when you reuse the machine.

As oil can be diluted during storage.

Apply an anticorrosive lubricant on the exposed part of piston rod of cylinder and in places where the machine rusts easily.

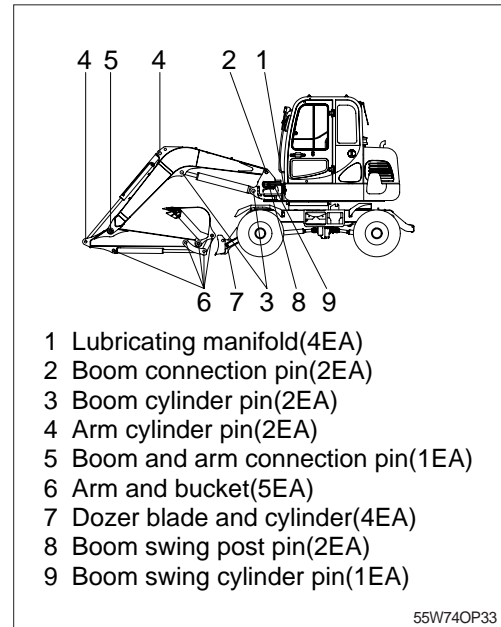

3) MASTER SWITCH

Turn OFF the master switch mounted battery box and store the machine.

4) Be sure to mix anticorrosive antifreezing solution in the radiator.

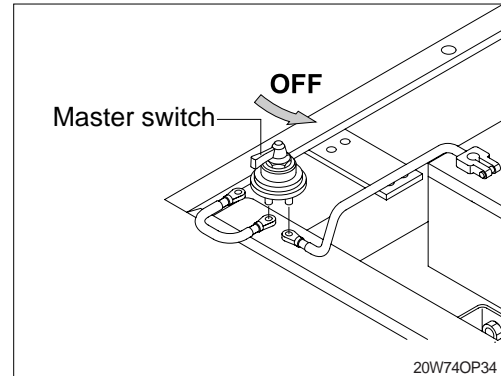

5) PREVENTION OF DUST AND MOISTURE

Keep machine dry. Store the machine setting wood on the ground.

※ Cover exposed part of piston rod of cylinder.

※ Lower the bucket to the ground and set a support tires.

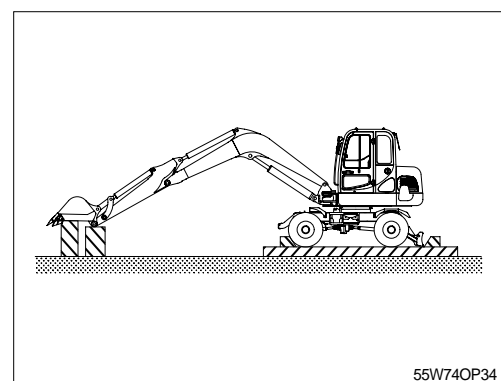

6) DURING STORAGE

Start engine and move the machine and work equipment once a month and apply lubrication to each part.

- ※ Check the level of engine oil and coolant and fill if required when starting engine.
- ※ Clean the anticorrosive on the piston rod of cylinder.
- ※ Operate the machine such as traveling, swing and work equipment operation to make sure enough lubrication of all functional components.

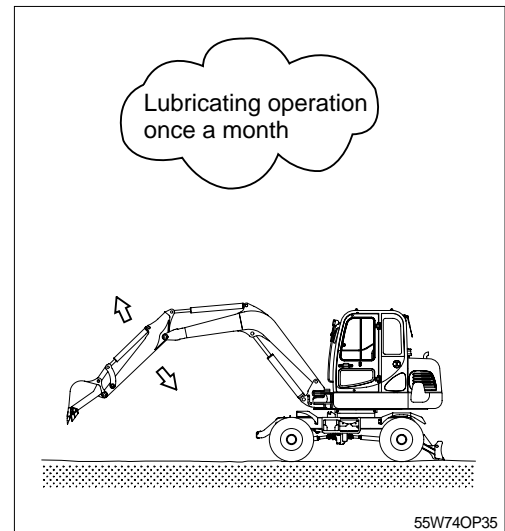

11. RCV LEVER OPERATING PATTERN

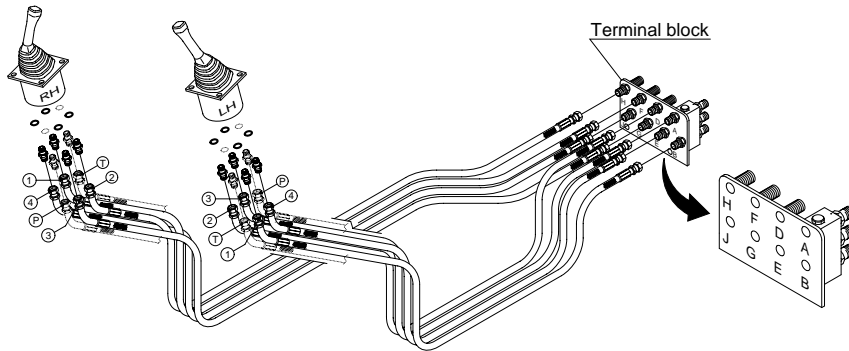

※ Whenever a change is made to the machine control pattern also exchange the pattern label in the cab to match the new pattern.

R5574OP40N

| Pattern | Operation | | Control function | Hose connection(Port) | | | |
|-------------------------|-----------|-------|------------------|-----------------------|--------------------|----|---|
| | Left | Right | | RCV lever | Change of MCV port | | |
| | | | | | From | To | |
| ISO Type Hyundai | | | Left | Arm out | ② | D | - |
| | | | | Arm in | ④ | E | - |
| | | | | Swing right | ③ | B | - |
| | | | | Swing left | ① | A | - |
| | | | Right | Boom lower | ④ | G | - |
| | | | | Boom raise | ② | F | - |
| | | | | Bucket out | ① | H | - |
| | | | | Bucket in | ③ | J | - |
| A Type | | | Left | Boom lower | ② | D | G |
| | | | | Boom raise | ④ | E | F |
| | | | | Swing right | ③ | B | - |
| | | | | Swing left | ① | A | - |
| | | | Right | Arm out | ④ | G | D |
| | | | | Arm in | ② | F | E |
| | | | | Bucket out | ① | H | - |
| | | | | Bucket in | ③ | J | - |
| B Type | | | Left | Boom lower | ② | D | G |
| | | | | Boom raise | ④ | E | F |
| | | | | Bucket in | ③ | B | J |
| | | | | Bucket out | ① | A | H |
| | | | Right | Arm out | ④ | G | D |
| | | | | Arm in | ② | F | E |
| | | | | Swing right | ① | H | B |
| | | | | Swing left | ③ | J | A |
| C Type | | | Left | Swing right | ② | D | B |
| | | | | Swing left | ④ | E | A |
| | | | | Arm in | ③ | B | E |
| | | | | Arm out | ① | A | D |
| | | | Right | Same as ISO type | | | |