

## 5. QUICK CLAMP

### 1) FIXING BUCKET WITH QUICK CLAMP

- (1) Before fixing bucket, remove safety pin of the moving hook.
- (2) Pulling safety button, press the quick clamp switch to unlock position. Then, the moving hook is placed on release position.

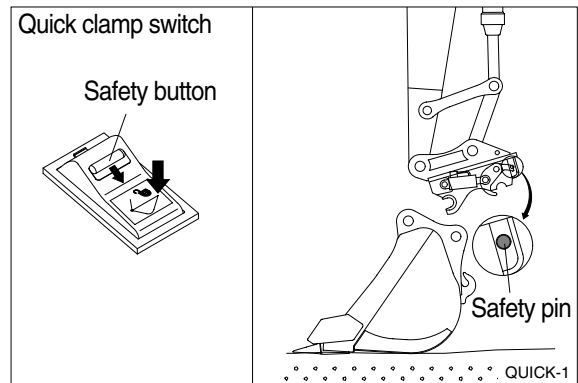

- (3) Aligning the arm and bucket, insert static hook of quick clamp to the bucket pin.

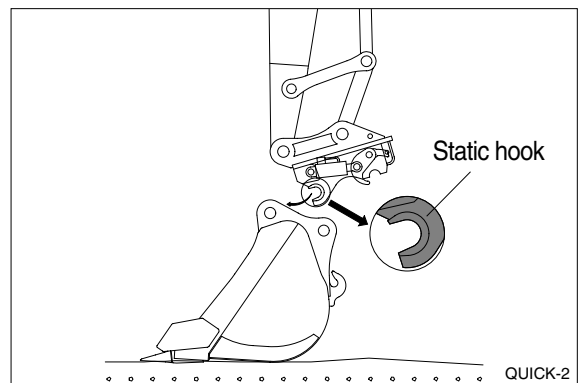

- (4) Operate RCV lever to bucket-in position. Then, the moving hook is coupled with the bucket link pin. Make sure that the moving hook is completely contacted with bucket link pin.

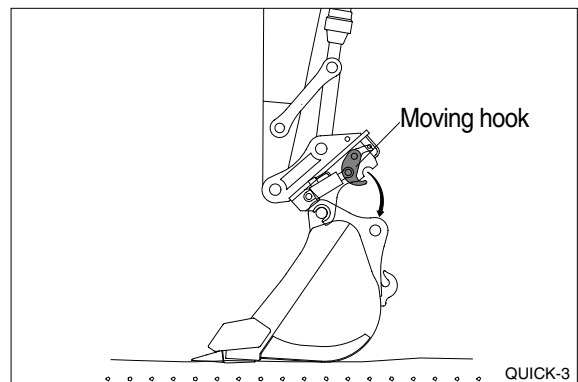

- (5) Press quick clamp switch to lock position. Operate RCV lever to bucket-in position.  
※ **Be sure to check connection status between bucket pins and hooks of quick clamp**

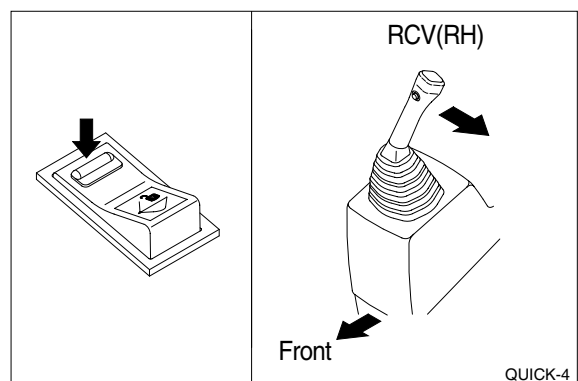

- (6) After checking the connection status between bucket pins and hooks of quick clamp, insert safety pin of moving hook to lock position.

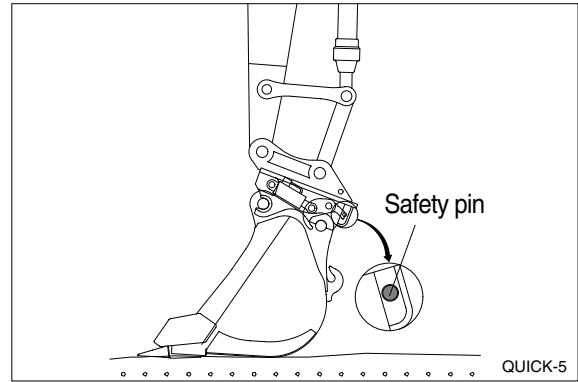

## 2) REMOVE BUCKET FROM QUICK CLAMP

Removing procedure is reverse of fixing.

## 3) PRE-CAUTION OF USING QUICK CLAMP

- ⚠ When operating the machine with quick clamp, confirm that the quick clamp switch is lock position and safety pin of moving hook is inserted.

Operating the machine with quick clamp switch unlocked and without safety pin of moving hook can cause the bucket to drop off and bring about the accident.

Serious injury or death can result from this accident.

- ⚠ Be careful to operate the machine equipped with quick clamp. The bucket may hit cab, boom and boom cylinders when it reaches vicinity of them.

HYUNDAI will not be responsible for any injury or damage in case that safety pin is  
※ not installed properly.

