

6. SERVICE INSTRUCTION

1) CHECK ENGINE OIL LEVEL

Check the oil level with the machine on a flat ground before starting engine.

- (1) Pull out the dipstick and wipe with a clean cloth.
- (2) Check the oil level by inserting the dipstick completely into the hole and pulling out again.
- (3) If oil level is LOW, add oil and then check again.
 - ※ If the oil is contaminated or diluted, change the oil regardless of the regular change interval.
 - ※ Check oil level after engine has been stopped for 15 minutes.
 - ▲ Do not operate unless the oil level is in the normal range.

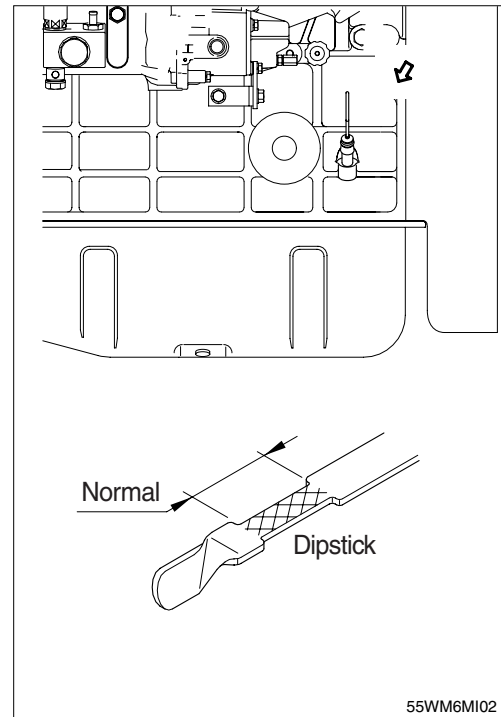

2) REPLACEMENT OF ENGINE OIL AND OIL FILTER

- (1) Warm up the engine.
- (2) Remove the plug and allow the oil to drain.
 - Wrench size : 19mm
 - ※ A drain pan with a capacity of 28 liters(7.4 U.S. gallons) will be adequate.

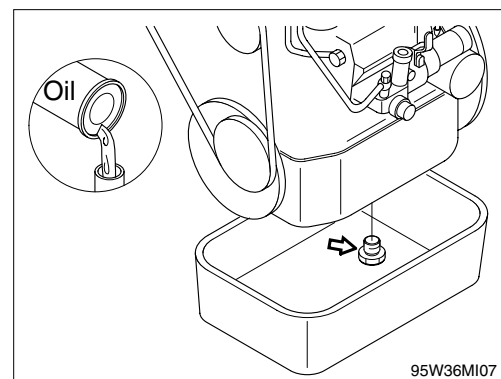

- (3) Clean around the filter head, remove the filter and clean the gasket surface.
 - Wrench size : 90mm(3.5in)
 - Clean the filter mounting surface.
 - Tighten with the filter wrench by about 3/4 turn.
 - Tightening torque : 2.0~2.4kgf · m
(14.5~17.4lbf · ft)

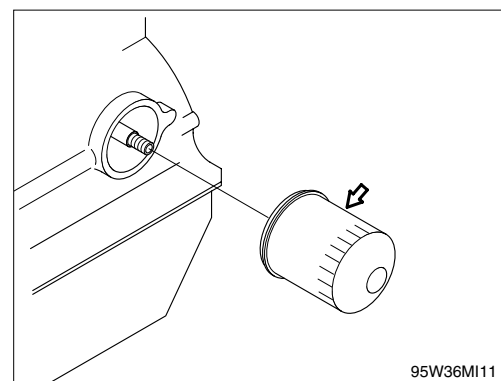

- (4) Apply a light film of lubricating oil to the gasket sealing surface before installing the filters.
※ **Fill the filters with clean lubricating oil.**

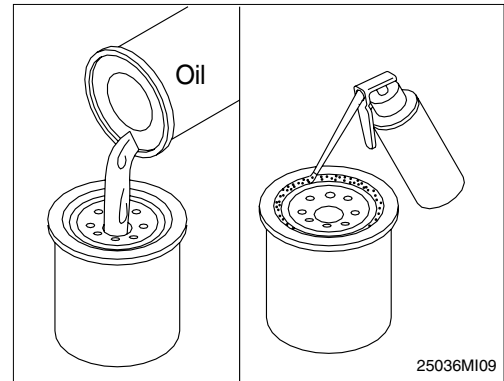

- (5) Fill the engine with clean oil to the proper level.
· Quantity : 9.7 l (2.9U.S.gallons)

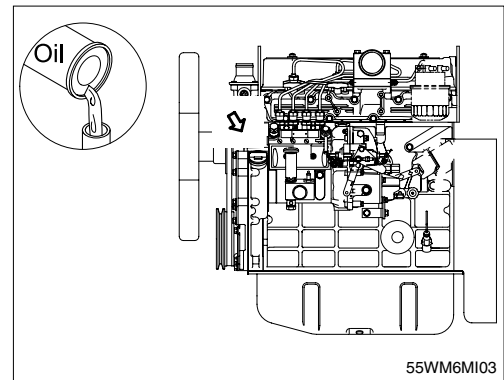

- (6) Operate the engine at low idle and inspect for leaks at the filters and the drain plug.
Shut the engine off and check the oil level with the dipstick. Allow 15 minutes for oil to drain down before checking.

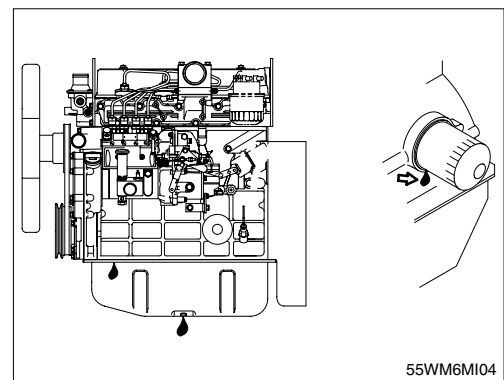

3) CHECK COOLANT

- (1) Check if the level of coolant in reservoir tank is between FULL and LOW.
- (2) Add the mixture of antifreeze and water after removing the cap of the reservoir tank if coolant is not sufficient.
- (3) Be sure to use the reservoir empty, add the coolant by opening the cap of radiator.
- (4) Replace gasket of radiator cap when it is damaged.

▲ Hot coolant can spray out if radiator cap is removed while engine is hot. Remove the cap after the engine has cooled down.

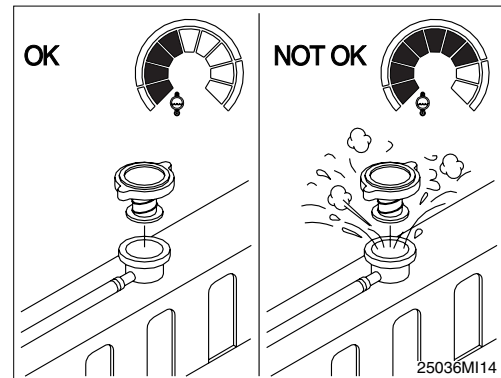
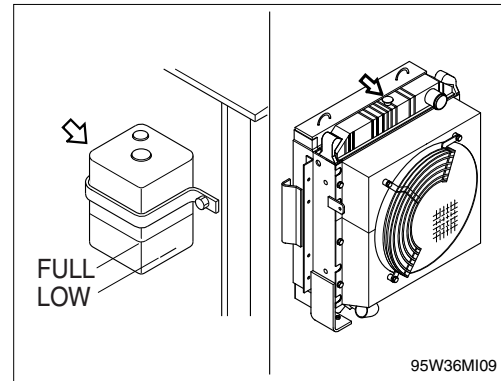

4) FLUSHING AND REFILLING OF RADIATOR

- (1) Change coolant

▲ Avoid prolonged and repeated skin contact with used antifreeze. Such prolonged repeated contact can cause skin disorders or other bodily injury. Avoid excessive contact-wash thoroughly after contact. Keep out of reach of children.

※ Protect the environment : Handling and disposal of used antifreeze can be subject to federal, state, and local law regulation. Use authorized waste disposal facilities, including civic amenity sites and garages providing authorized facilities for the receipt of used antifreeze. If in doubt, contact your local authorities for guidance as to proper handling of used antifreeze.

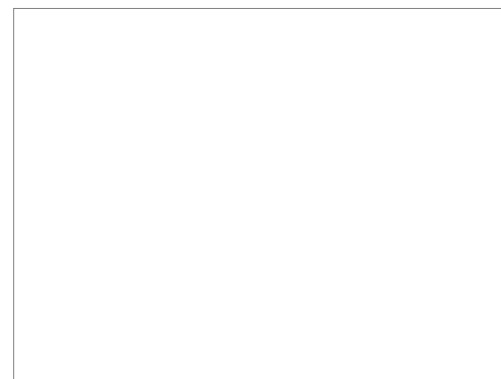
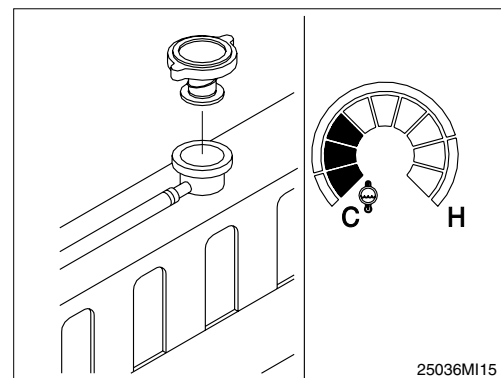

- ▲ Wait until the temperature is below 50° C (120° F) before removing the coolant system pressure cap.

Failure to do so can cause personal injury from heated coolant spray.

Drain the cooling system by opening the drain valve on the radiator and removing the plug in the bottom of the water inlet. A drain pan with a capacity of 20 liters(5U.S.gallons) will be adequate in most applications.

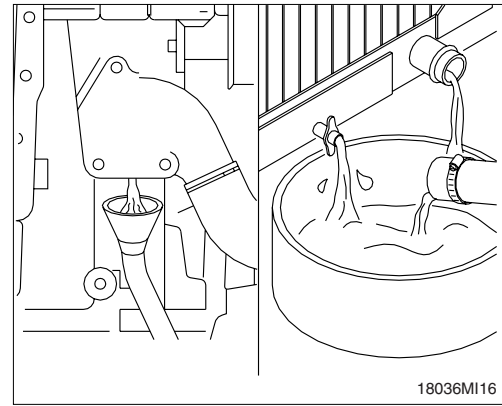

(2) Flushing of cooling system

- ① Fill the system with a mixture of sodium carbonate and water(or a commercially available equivalent).
 - ※ Use 0.5kg(1.0pound) of sodium carbonate for every 23 liters(6.0U.S. gallons) of water.
 - ※ Do not install the radiator cap. The engine is to be operated without the cap for this process.

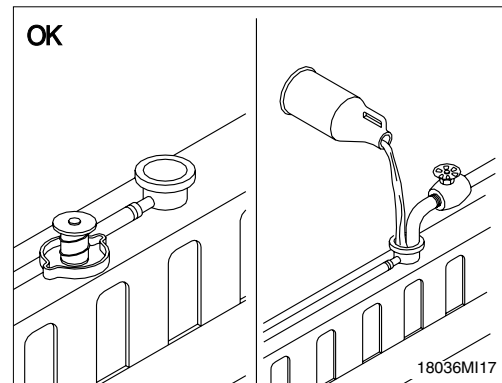

- ② Operate the engine for 5 minutes with the coolant temperature above 82°C(180°F) . Shut the engine off, and drain the cooling system.

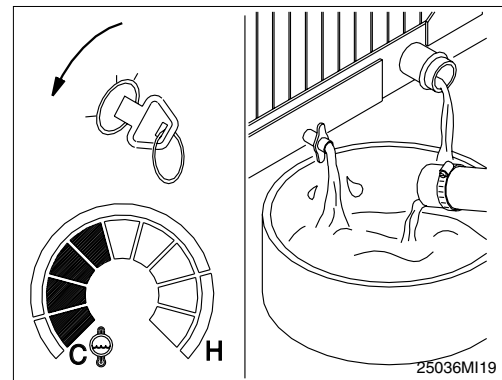

- ③ Fill the cooling system with clean water.
 - ※ Be sure to vent the engine and aftercooler for complete filling.
 - ※ Do not install the radiator cap or the new coolant filter.

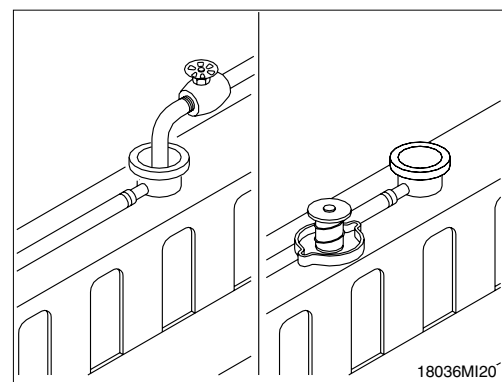

- ④ Operate the engine for 5 minutes with the coolant temperature above 82°C(180°F) .
Shut the engine off, and drain the cooling system.
- ※ If the water being drained is still dirty, the system must be flushed again until the water is clean.

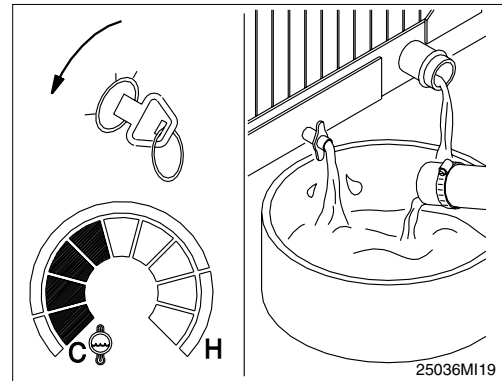

(3) Cooling system filling

- ① Use a mixture of 50 percent water and 50 percent ethylene glycol antifreeze to fill the cooling system.
Coolant capacity(engine only) : 4.2 l (1.1U.S. gallons)
- ※ Use the correct amount of DCA4 corrosion inhibitor to protect the cooling system.

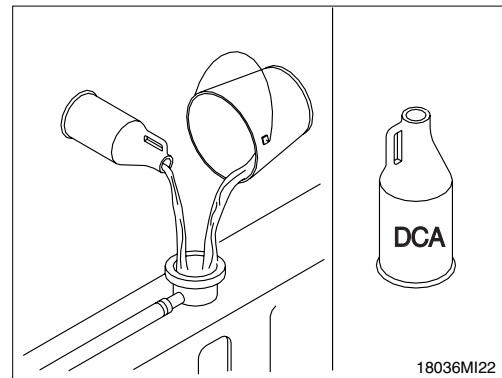

- ② Install the pressure cap. Operate the engine until it reaches a temperature 82° C(180° F) and check for coolant leaks.
Check the coolant level again to make sure the system is full of coolant.

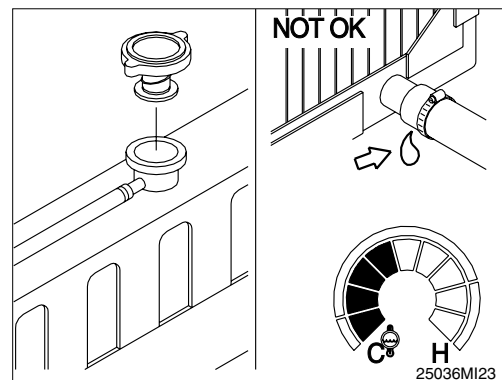

5) CLEAN RADIATOR AND OIL COOLER

Check, and if necessary, clean and dry outside of radiator and oil cooler. After working in a dusty place, clean radiator more frequently.

- (1) Visually inspect the radiator for clogged radiator fins.
- (2) Use 200kPa(29psi) air pressure to blow the dirt and debris from the fins.
Blow the air in the opposite direction of the fan air flow.
- (3) Visually inspect the radiator for bent or broken fins.
※ **If the radiator must be replaced due to bent or broken fins which can cause the engine to overheat, refer to the manufacturer's replacement procedures.**
- (4) Visually inspect the radiator for core and gasket leaks.

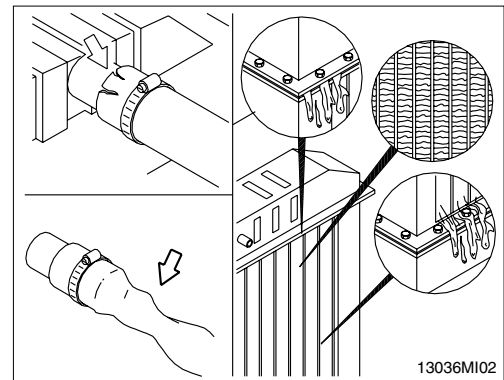
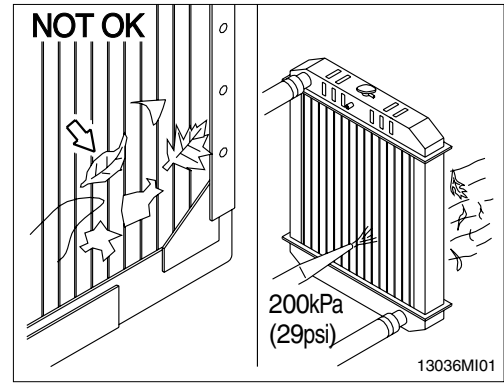

6) FAN BELT TENSION

- (1) Measure the belt deflection at the longest span of the belt.
 - Maximum deflection : 10 - 15mm(0.4~06inch)

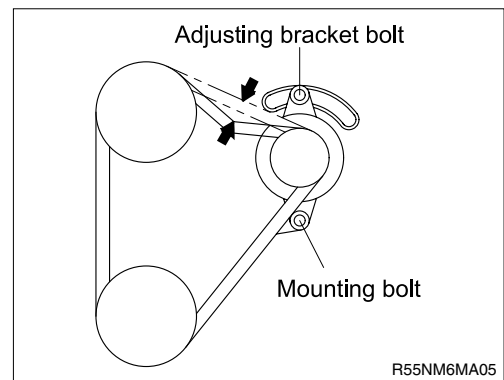

- (2) Inspect the drive for damage.

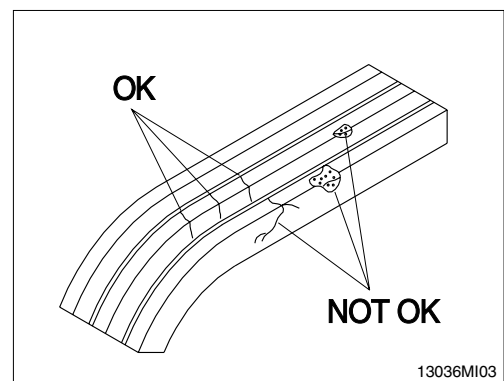

7) CLEANING OF AIR CLEANER

- (1) Loosen the wing nut and remove the element.
- (2) Clean the inside of the body.
- (3) Clean the element either with pressurized air or washing.
 - ① **Using pressurized air**
Remove the dust inside of the element by the pressurized air (below 7kg/cm², 100psi) forward and backward equally.
 - ② **Washing**
Wash the element with a neutral detergent which does not cause bubbles.
Dry off after washing with water.

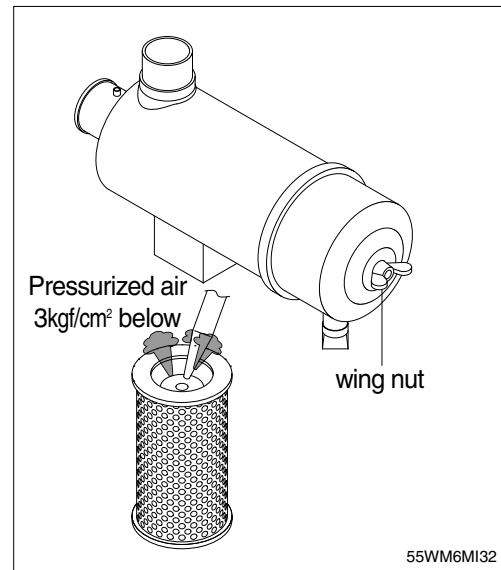

- (4) Inspect for cracks or damage of element by putting a light bulb inside of the element.
 - (5) Insert element and tighten wing nut.
- ※ **Replace the element with new one after use 250 hours (6 times washing), or if damage is found.**
 - ※ **Clean the air cleaner element when the air cleaner warning lamp on the cluster lights ON.**

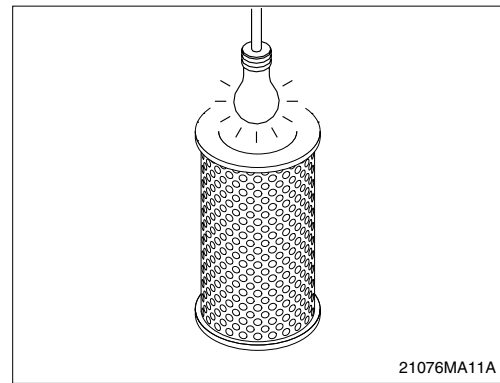

8) FUEL TANK

- (1) Fill fuel fully when system the operation to minimize water condensation, and check it with fuel gauge before starting the machine.
 - (2) Drain the water and sediment in the fuel tank by opening the drain cock.
- ※ **Be sure to LOCK the cap of fuel tank.**
 - ※ **Remove the strainer of the fuel tank and clean it if contaminated.**
 - ▲ **Stop the engine when refueling.**
All lights and flames shall be kept at a safe distance while refueling.

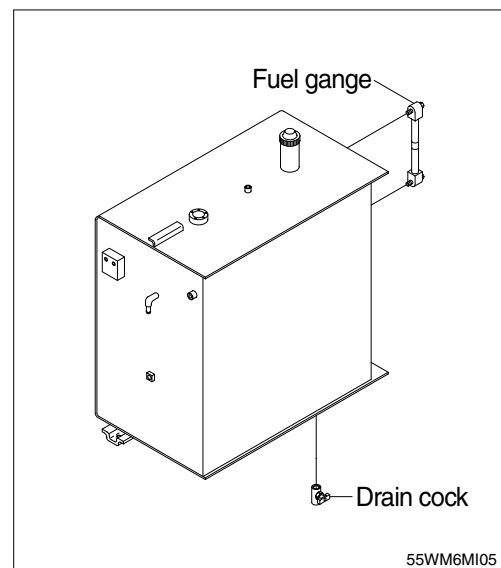

9) WATER SEPARATOR

- (1) Drain the water and sediment by loosening the drain plug.
- (2) Retighten the drain plug.
- (3) Check for leakage.
 - ※ **Drain the water if it reaches the red line regardless of the service interval.**
 - ※ **Bleed the air if the air is mingled on the fuel line when draining water.**

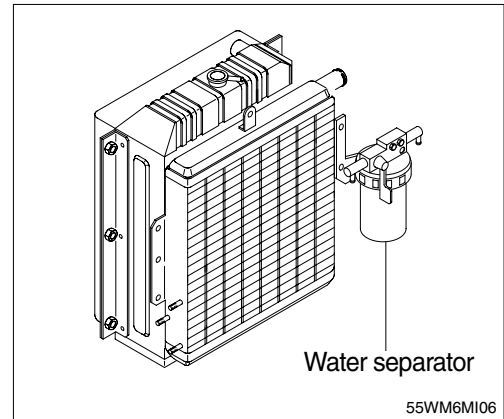

10) REPLACEMENT OF FUEL FILTER

- (1) Close the fuel cock after closing the water separator cock.
- (2) By using the filter wrench, remove the fuel filter. (Turn it counter-clockwise)
- (3) Clean the filter mounting surface.
- (4) Set a new fuel filter and fully tighten onto the mounting surface manually. Then, tighten by about 1/2 turn by using the filter wrench. (Clockwise, tightening torque : 1.2 ~ 1.6kgf · m)
- (5) Open the water separator cock.

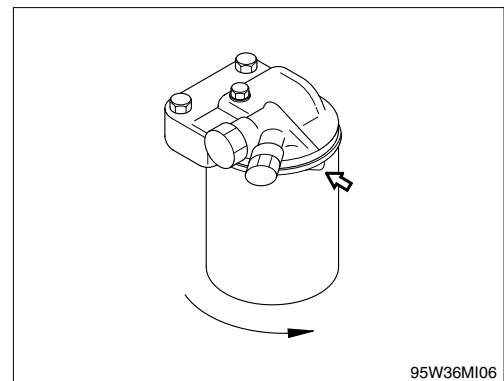
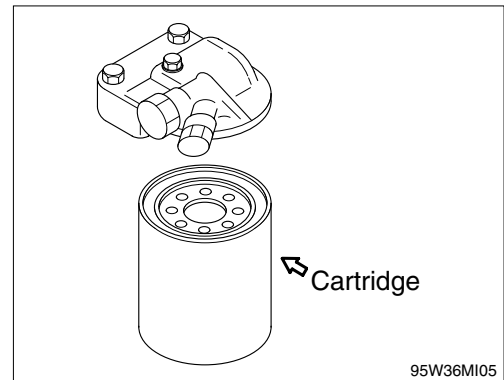

11) BLEEDING THE FUEL SYSTEM

If the engine cannot be started after trying several times, check the fuel system first.

If the fuel system contains air, the fuel cannot be fed to the fuel injection pump.

Bleed air from the fuel system as described below. After air bleeding, perform the start operation again.

- (1) Loosen the air bleeding bolt on top of the fuel filter by two or three turns.
- (2) Feed the fuel by using the feed pump. Loosen the priming knob by turning it counter-clockwise then manually pump it vertically.
- (3) The fuel containing air bubbles comes out of the air bleeding bolt hole on the fuel filter. After checking the flowing out fuel contains no air bubble, tighten the air bleeding bolt.
- (4) Press the priming knob down and turn it clockwise for tightening.
- (5) Set the starting switch key to the START position and crank the engine. After a while, the fuel is fed. Fuel injection begins and the engine starts.

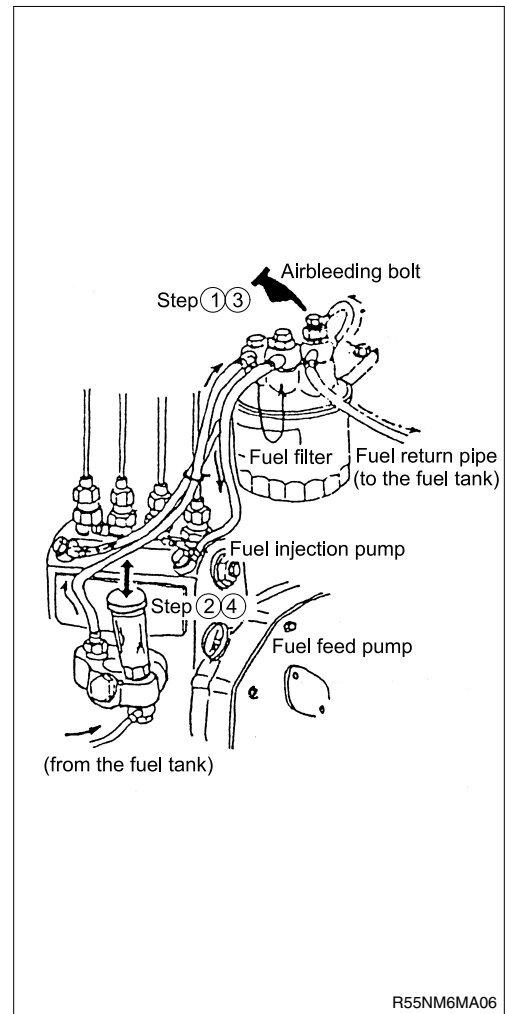

11) LEAKAGE OF FUEL

- ▲ Be careful and clean the fuel hose, injection pump, fuel filter and other connections as the leakage from these part can cause fire.**

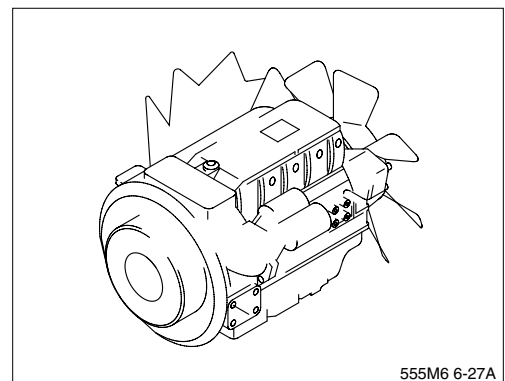

13) HYDRAULIC OIL CHECK

- (1) Stop the engine after retract the arm and bucket cylinders, then lower the boom and set the bucket on the ground at a flat location as in the illustration.
- (2) Check the oil level at the level gauge of hydraulic oil tank.
- (3) The oil level is normal if between the **H** and **L** points.

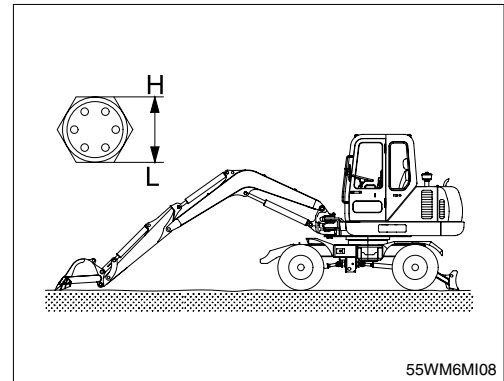

14) FILLING HYDRAULIC OIL

- (1) Stop the engine to the position of level check.
- (2) Remove the cover of the hydraulic oil tank.
- (3) Relieve the pressure by loosening the breather cap on the top of hydraulic oil tank.
- (4) Remove the breather on the top of oil tank and fill the oil to the specified level.
- (5) Start engine after filling and operate the work equipment several times.
- (6) Check the oil level at the level check position after engine stops.

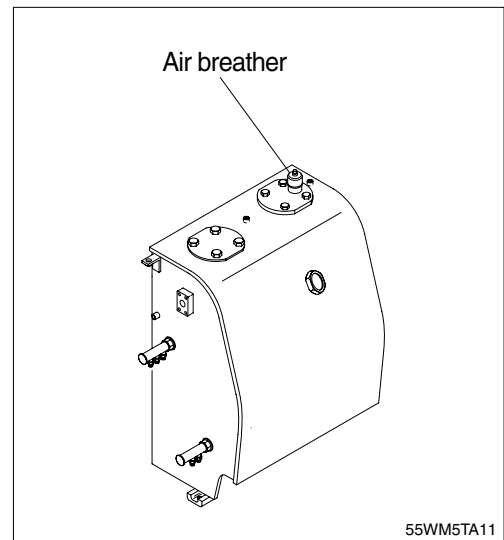

15) CHANGE HYDRAULIC OIL

- (1) Lower the bucket on the ground pulling the arm and bucket cylinder to the maximum.
- (2) Relieve the pressure loosening the breather cap on the top of the oil tank.
- (3) Remove the cover on the top of the oil tank.
- (4) Prepare a suitable container.
- (5) To drain the oil loosen the drain plug at the bottom of the oil tank.
- (6) Fill proper amount of recommended oil.
- (7) Put the breather in the right position.
- (8) **Bleed air hydraulic pump loosen the air breather at top of hydraulic pump assembly.**
- (9) Start engine and run continually. Release the air by full stroke of each control lever.

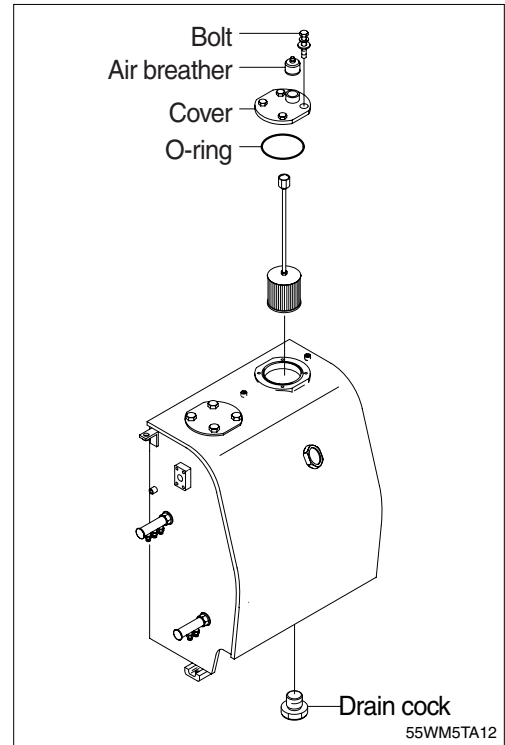

16) CLEAN SUCTION STRAINER

Clean suction strainer as follows paying attention to the cause to be kept during oil filling.

- (1) Remove the cover on the top of the oil tank.
 - (2) Pull out the strainer in the tank.
 - (3) Wash the foreign material on the suction strainer with gasoline or cleaning oil.
 - (4) Replace the suction strainer if it is damaged.
 - (5) Assemble with reverse order of disassembly. Be sure to install a new O-ring and reinsert in the oil tank.
- ※ **Loosen the bolt slowly at the cover can be spring out by the spring when removing it.**

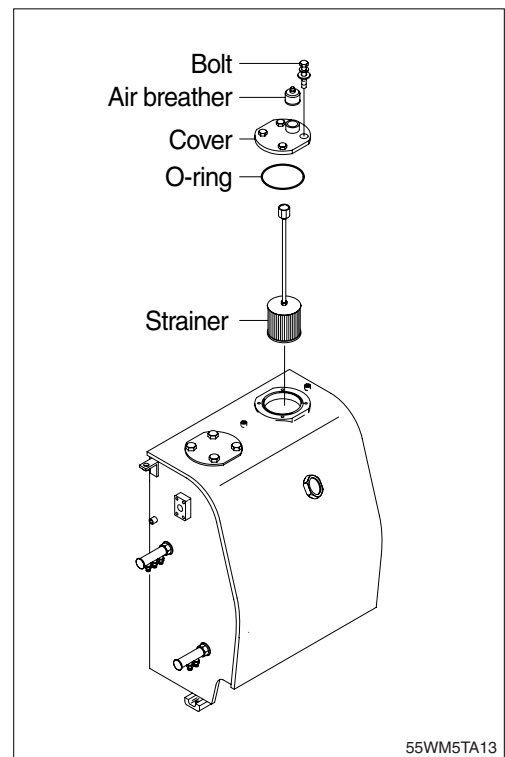

17) REPLACEMENT OF RETURN FILTER

Replace as follows paying attention to the cause to be kept during the replacement.

- (1) Remove the cover on the top of the oil tank.
- (2) Remove the spring, by-pass valve, and return filter in the tank.
- (3) Replace the element with new one.

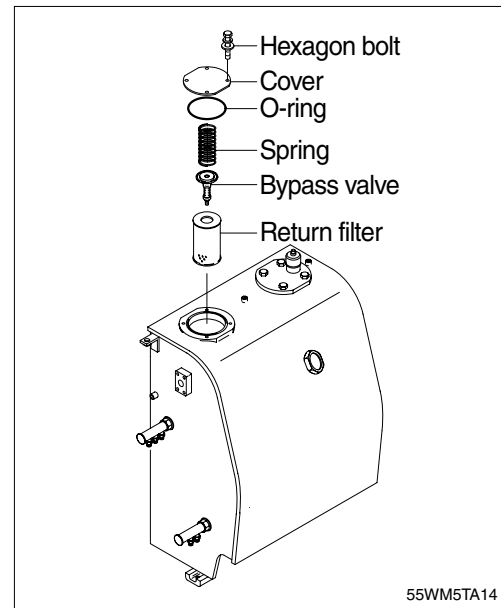

18) REPLACEMENT OF ELEMENT IN HYDRAULIC TANK BREATHER

- (1) Open the cap of the breather on the top of the oil tank and relieve the pressure.
- (2) Loosen the breather mounting bolt.
- (3) Remove the cover and pull out the filter element.
- (4) Replace the filter element and O-ring with new one.
- (5) Apply oil on the O-ring and reassemble by reverse order of disassembly.

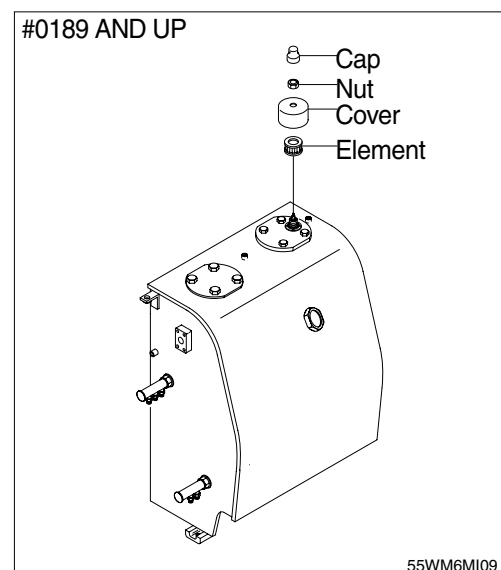
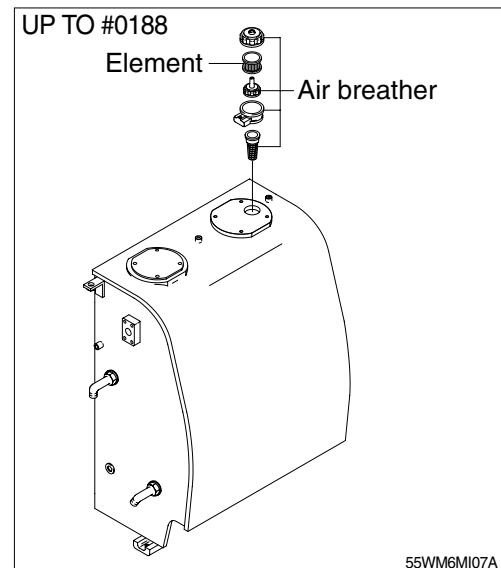

19) REPLACE OF DRAIN FILTER CARTRIDGE

- (1) Loosen the nut positioned on the filter body.
 - (2) Pull out the filter element and clean filter housing.
 - (3) Install the new element and tighten using specified torque.
- ※ **Change cartridge after initial 50 hours of operation. Thereafter, change cartridge every 250 hours.**

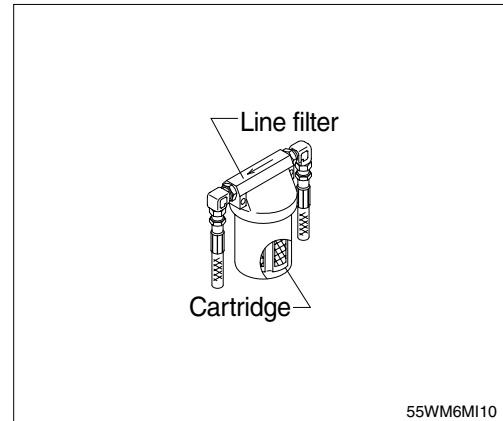

20) CHANGE THE SWING REDUCTION GEAR OIL

- (1) Pull out the dipstick and clean it.
- (2) Insert it again.
- (3) Pull out one more time to check the oil level and fill the oil if the level is not sufficient.

21) CHANGE SWING REDUCTION GEAR OIL

- (1) Raise the temperature of oil by swinging the machine before replace the oil and park the machine on the flat ground.
- (2)
- (3) Loosen the plug of the drain port.
Drain into a proper container.

Wash the drain plug and reinstall it with sealing tape.

Fill proper amount of recommended oil.

- Amount of oil : 0.6 l (0.16U.S.gal)

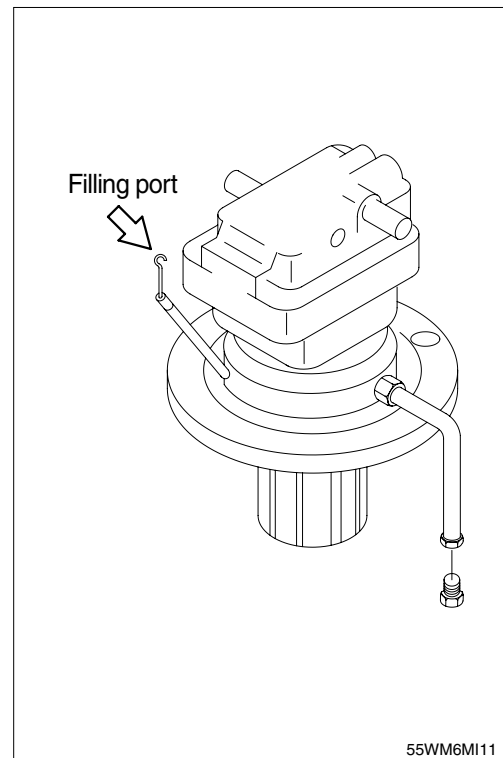

22) LUBRICATE SWING BEARING

- (1) Grease at 3 fitting.
- ※ **Lubricate every 50 hours.**

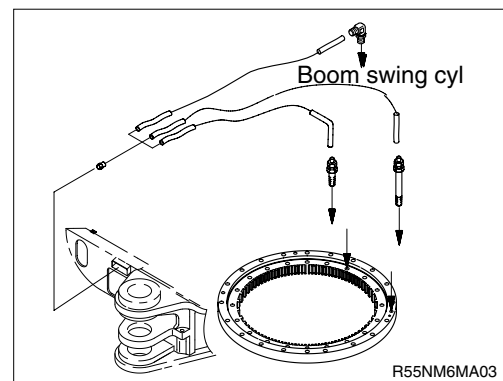

23) LUBRICATE RCV LEVER

Remove the bellows and with grease gun grease the joint part(A) and sliding parts(B).

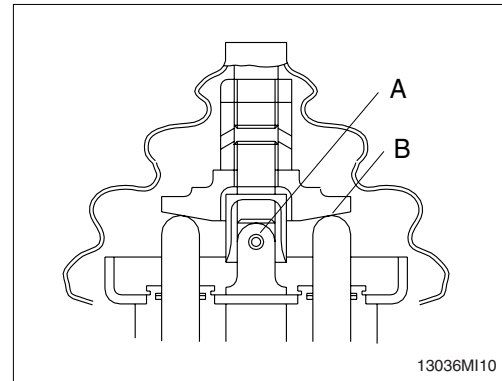

24) LUBRICATE

(1) Drive shaft

- ① Front drive shaft : 3 point
- ② Rear drive shaft : 3 point

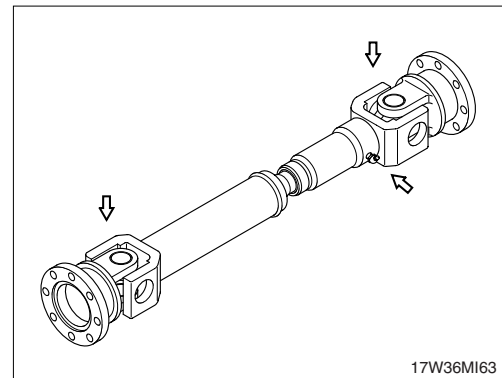

(2) Axle

- ① Front axle : 1 point

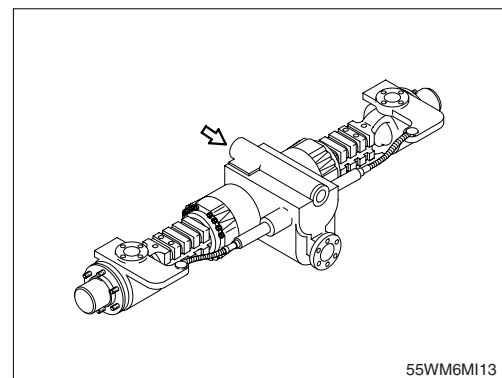

- ② Rear axle ; 2 point

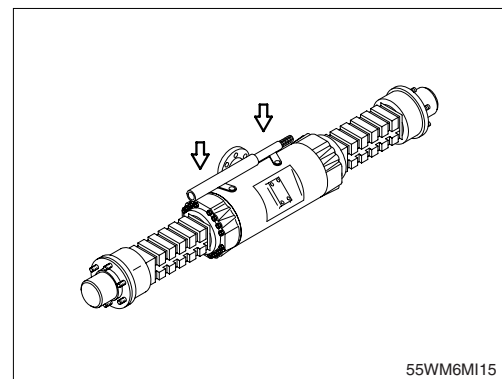

(3) Steering link : 4 point

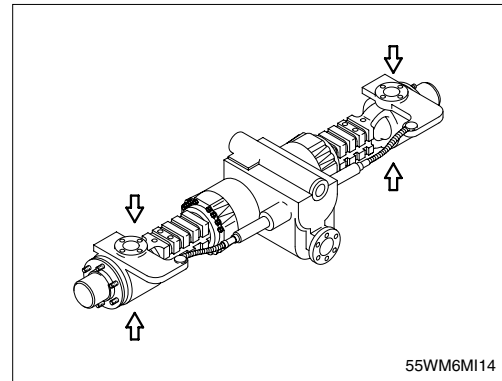

(4) Dozer blade : 4 point

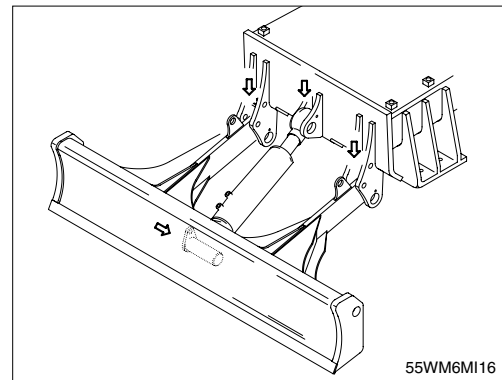

25) TIRE

(1) Air pressure

It is important to keep air pressure properly for maximizing tire life. Both excessive and insufficient air pressure of tires should be avoided not to damage tires.

- Specification : 5.25kg/cm²(75psi)

(2) Handling of tire

① Removal of tire

- Lift the main body until a tire separate from the ground, and place the block under front and rear axle.
- Loosen wheel nut with torque wrench and remove tire.

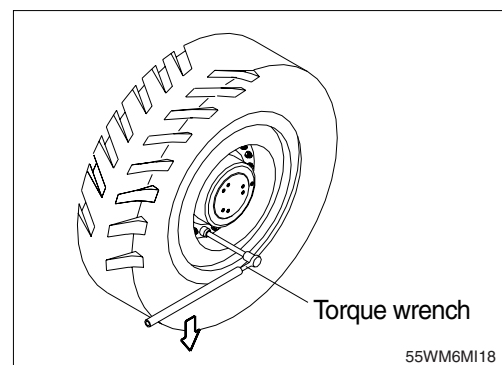

② Installation of tire

- Coat some grease on wheel stud and nut screw.
- Install the tires and tighten a nut slightly and get down a tire on the ground, and then tighten the torque in the order as figure.
 - Tightening torque : 25.2~34.2kgf · m
(182~247lb · ft)

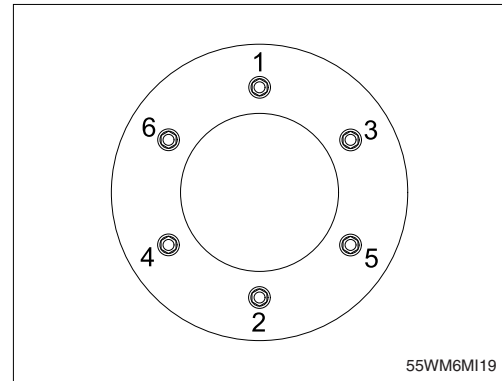

③ Position change of tire

- Tire is worn out differently part by part according to installing position, so change position regular-ly as figure.
Keep air pressure at standard.
Use same pattern of groove and same maker's tire.

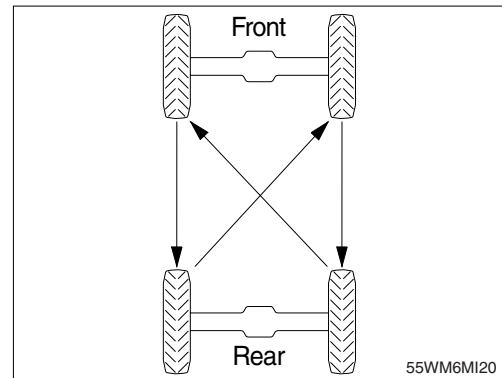

26) CHECK PLANETARY GEAR OIL LEVEL

- (1) Move the machine to flat ground.
- (2) Remove the plug and check the oil amount.
- (3) If the oil level is below the plug hole, supply oil through a plug hole.
 - ※ **Set the plug of planetary gear in parallel to the ground.**
- (4) After checking, install plug.

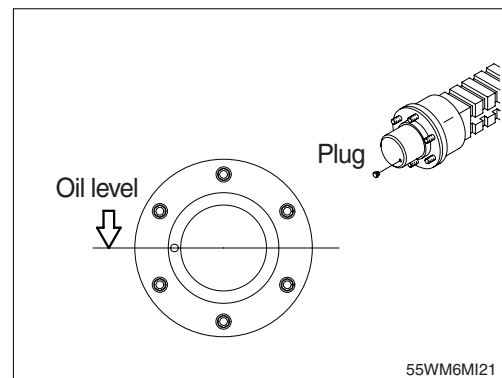

27) CHECK AND SUPPLYING AXLE OIL

- (1) Move the machine to flat ground.
- (2) Open the axle air breather to relieve internal air pressure.

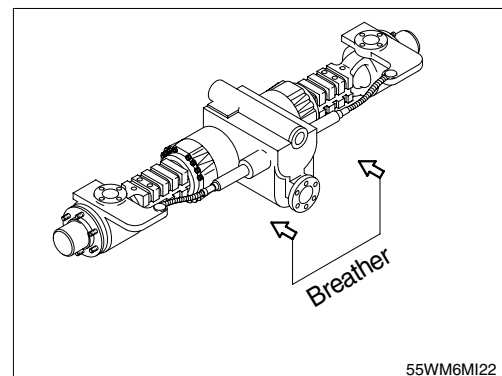

- (3) Remove the plug and check the oil amount.
If the oil level is at the hole of the plug, it is normal.
 - (4) If the oil level is below the plug hole, supply oil through a plug hole.
- ▲ **When checking the oil level, press the service brake.**
- ▲ **As the machine is hot after operation, wait until the oil temperature has dropped.**

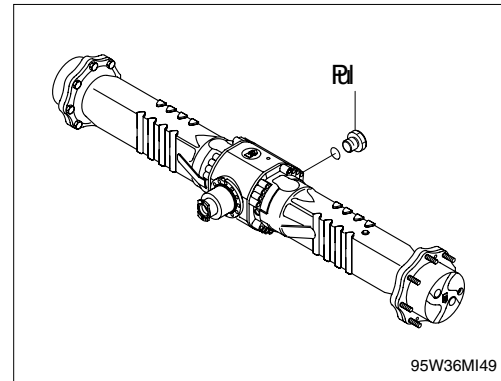

28) CHANGE THE AXLE OIL

- (1) Place a drain box under drain plug to catch oil.
- (2) Remove the air breather to relieve internal pressure.
- (3) **Drain oil into the differential gear**
 - ① Remove the filling plug and remove the drain plug to drain oil off.
 - ② Wash drain plug and install it

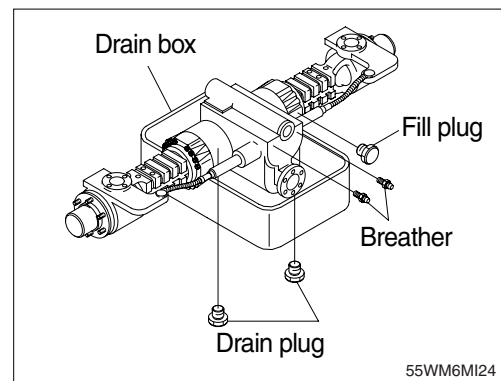

- (4) **Drain oil into the planetary gear**
 - ① Drain oil by removing drain plug.
 - ※ **The drain plug should be facing to the ground.**

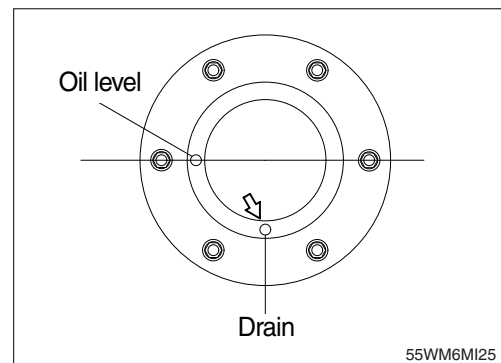

- (5) Supply oil into the differential gear and the planetary gear.
 - Oil amount
 - Front axle differential gear : 4.5 l (1.2U.S.gal)
 - Rear axle differential gear : 4.0 l (1.1U.S.gal)
 - Planetary gear case : 2.0 l (0.5U.S.gal)
 - (6) Supply oil until it overflows from the oil filler, then install the plug.
- ▲ **As the machine is hot after operation, wait until the temperature has dropped.**
- ※ **If a work requires frequent use of brake, replace it earlier than normal change interval.**

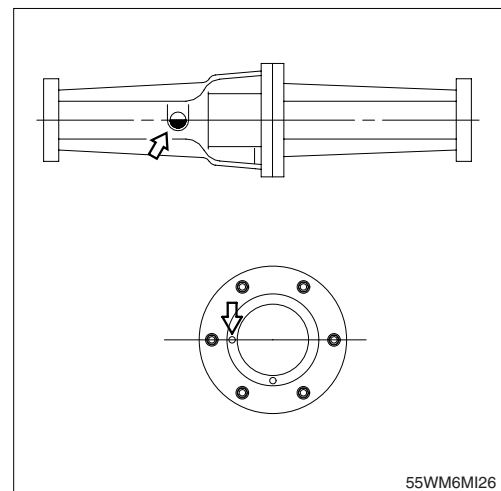

29) CLEANING AXLE BREATHER

- (1) Remove dust or debris around the breather.
- (2) remove the breather and wash it with cleaning oil.

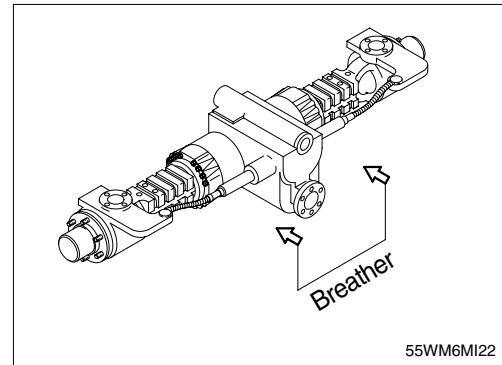

30) CHECK AND SUPPLYING TRANSMISSION OIL

- (1) Move the machine to flat ground.
- (2) Open the transmission air breather to relieve internal air pressure.
- (3) Remove the plug and check the oil amount. If the oil level is at the hole of the plug, it is normal.
- (4) If the oil level is below the plug hole, supply oil through a plug hole.

⚠ As the machine is hot after operation, wait until

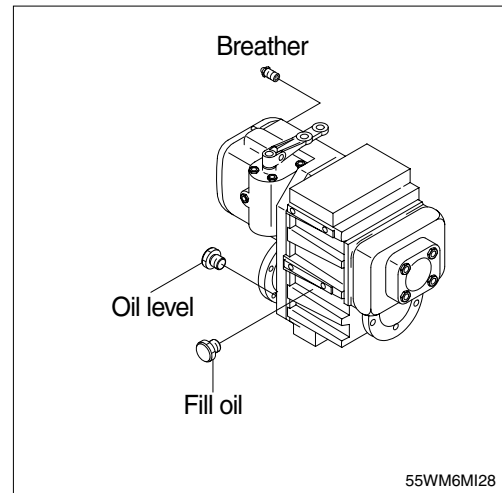

31) CHANGE THE TRANSMISSION OIL

- (1) Place a drain box under drain plug to catch oil.
- (2) Open transmission air breather to relieve internal air pressure.
- (3) Remove the drain plug to drain oil.

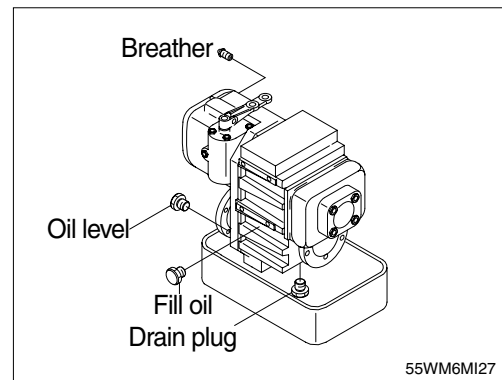

32) CLEANING TRANSMISSION AIR BREATHER

- (1) Remove dust or debris around the air breather.
- (2) Remove the air breather and wash it with cleaning oil.

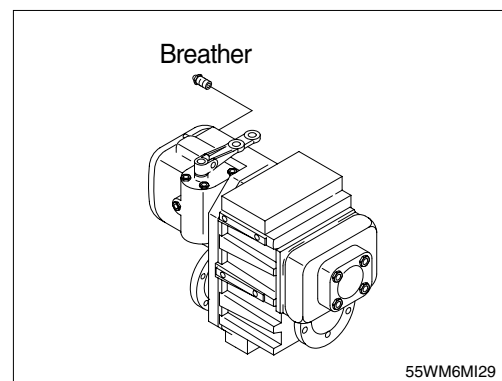

33) REPLACEMENT OF BUCKET TOOTH

(1) Timing of replacement

- ① Check wearing condition as shown in the illustration and replace tooth tip before adapter starts to wear.
- ② If excessive use, tooth adapter has worn out, replacement may become impossible.

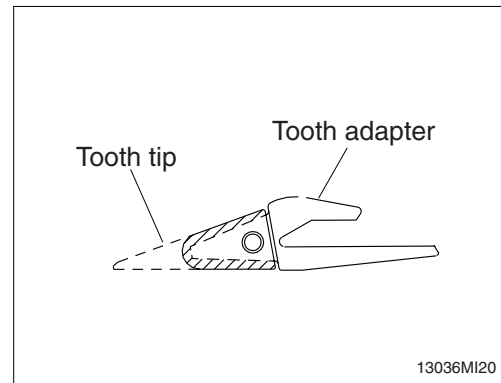

(2) Instructions for replacement

- ① Pull out pin by striking pin with punch or hammer, avoiding damage to locking rubber.
- ② Remove dust and mud from surface of tooth adapter by using knife.
- ③ Place locking rubber in its proper place and fit tooth tip to adapter.
- ④ Insert pin until locking rubber is positioned at tooth pin groove.

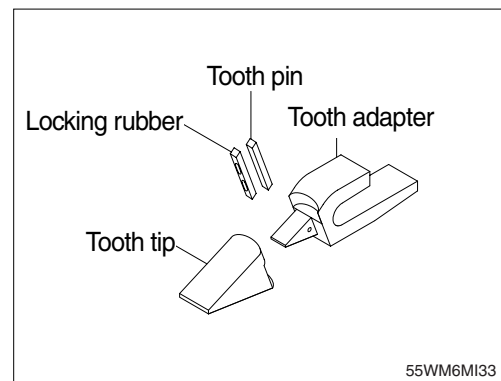

34) REPLACEMENT OF BUCKET

- △ When knocking the pin in with a hammer, metal particles may fly and cause serious injury, particularly if they get into your eyes. When carrying out this operation, always wear goggles, helmet, gloves, and other protective equipment. When the bucket is removed, place it in a stable condition.
- ※ When performing joint work, make sure signals to each other and work carefully for safety's sake.

Lower the bucket on the ground as the picture (1) shown in the right.

Lock the safety lever to the LOCK position and (2) stop the engine.

Remove the stopper bolts(1) and nuts(2), then (3) remove pins(3, 4) and remove the bucket.

When removing the pins, place the bucket so that it is in light contact with the ground.

- ※ If the bucket is lowered strongly to the ground, the resistance will be increased and it will be difficult to remove the pins.

After remove the pins, make sure that they do not become contaminated with sand or mud and that the seals of bushing on both sides do not become damaged.

Align the arm with holes(A) and the link with holes(B), then coat with grease and install pins(3, 4)

When installing the bucket, the O-rings are easily damaged, so fit the O-rings on the boss of the bucket as shown in the picture.

After knocking the pin, move the O-ring down to the regular groove.

Install the stopper bolt(1) and nuts(2) for each (5) pin, then grease the pin.

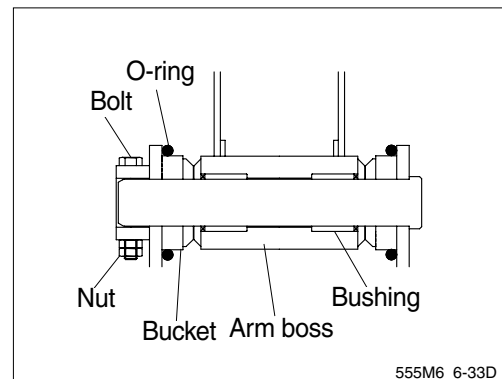
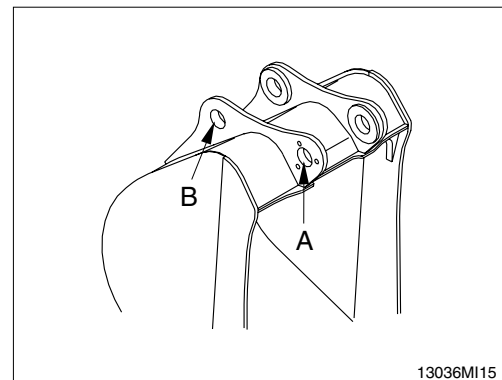
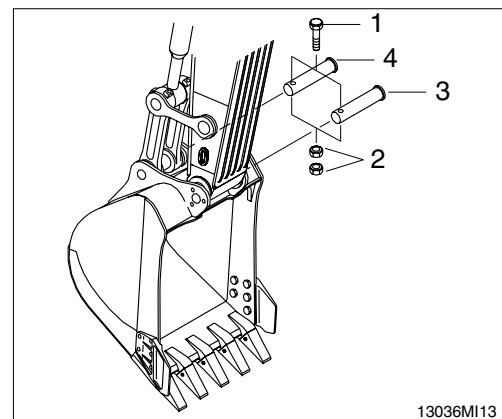
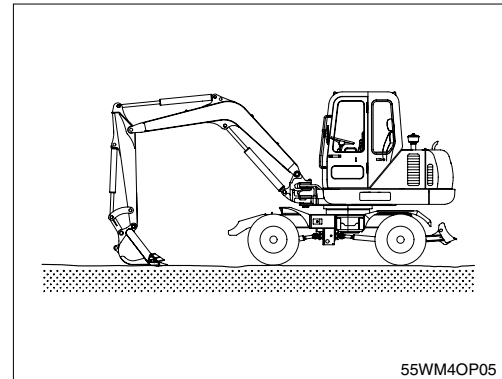

35) LUBRICATE PIN AND BUSHING

(1) Lubricate to each pin of working device

Lubricate the grease to the grease nipple according to the lubricating interval.

No.	Description	Qty
1	Lubrication manifold at upper frame	3
2	Boom connection pin	2
3	Boom cylinder pin	2
4	Boom and arm connection pin	1
5	Arm cylinder pin	2
6	Bucket cylinder pin(Head, rod)	2
	Bucket link(Control rod)	2
	Arm and bucket connection pin	1
	Arm and control link connection pin	1
7	Dozer connection pin	2
	Dozer cylinder pin	2

※ Shorten lubricating interval when working in the water or dusty place.

(2) Dust seals are mounted on the rotating part of working device to extend the lubricating interval.

※ Mount the lip to be faced outside when replace the dust seal.

※ If it is assembled in wrong direction, it will cause fast wear of pin and bushing, and create noise and vibration during operation.

※ Assemble the seal same direction with picture and use with plastic hammer when replace.

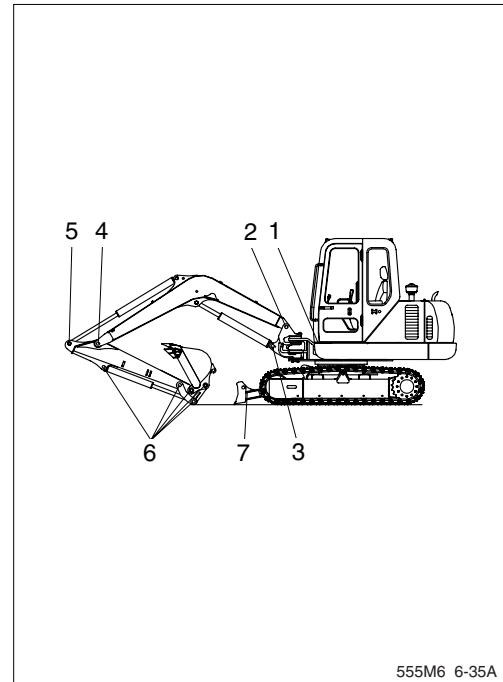

555M6 6-35A

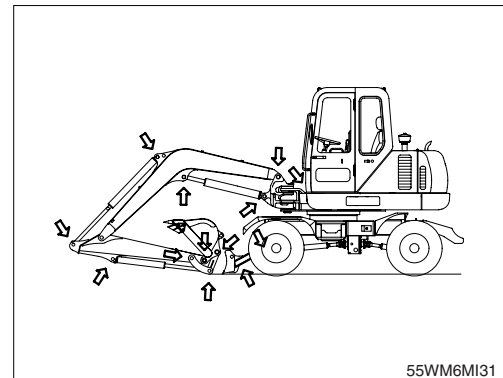

55WM6MI31

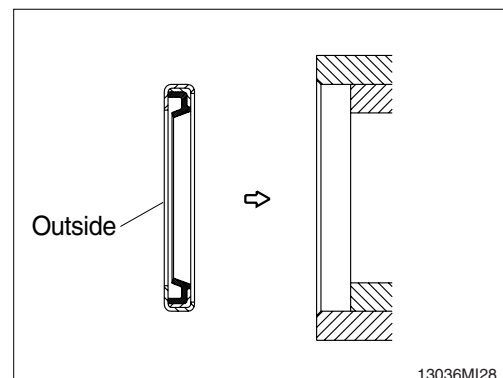

13036M128