

5. TRAVELING OF THE MACHINE

1) BASIC OPERATION

(1) Traveling position

It is the position which the traveling motor is in the rear and the working device is forward.

- ▲ **Travel directions will be reversed if lower structure is positioned with dozer in front.**

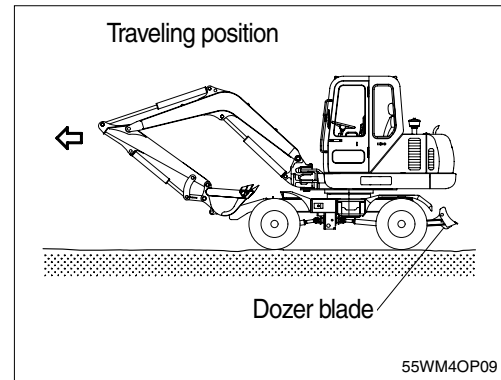

(2) Traveling operation

When warm-up operation is completed after the engine is started, move the machine according to the following procedure.

- ① Set the swing lock lever to release position.
 - ② Release the safety lever.
 - ③ Put the parking switch in the traveling position.
 - ④ Lift up the dozer blade or outrigger.
 - ⑤ Select traveling direction.
 - ⑥ Place the two speed switch in low speed.
 - ⑦ Press gently the acceleration pedal to move the machine.
- ※ **When speed up on a slope, a noise for valve of travel motor may occur. It is not out of order in machine but peculiar sound.**
 - ※ **Be sure that the brake works normally on the safe place before fast traveling.**

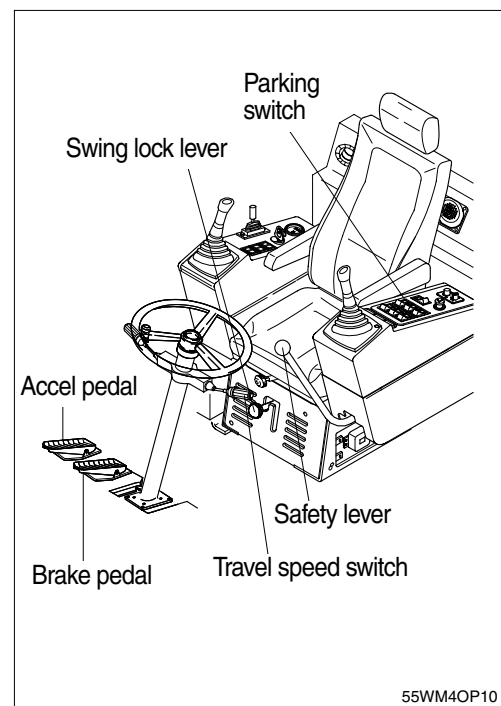

(3) How to change the travel speed

If you want to change the speed, be sure to operate according to the following procedure.

Otherwise, unreasonable operation may cause fatal impact and failure to the transfer box.(Gear box)

- ▲ In case of changing the travel speed, be sure to stop the machine completely.
- ▲ Keep the machine on the stationary state and stepping the brake pedal to full stroke.
Thereafter, select the speed switch to the desired position.(1→2, 2→1)
- ▲ When operating the travel speed switch without stepping brake pedal and stopping the machine completely, the operation of gear transmission can not be worked actually even though the position of speed switch is left to the desired position.
- ▲ When turning the key switch to "OFF" position to stop the machine, be sure to transfer the travel speed switch to the 1st speed position.
Because the position of solenoid valve for travel is automatically transferred to the 1' st speed position when turning the key switch to "off" position.

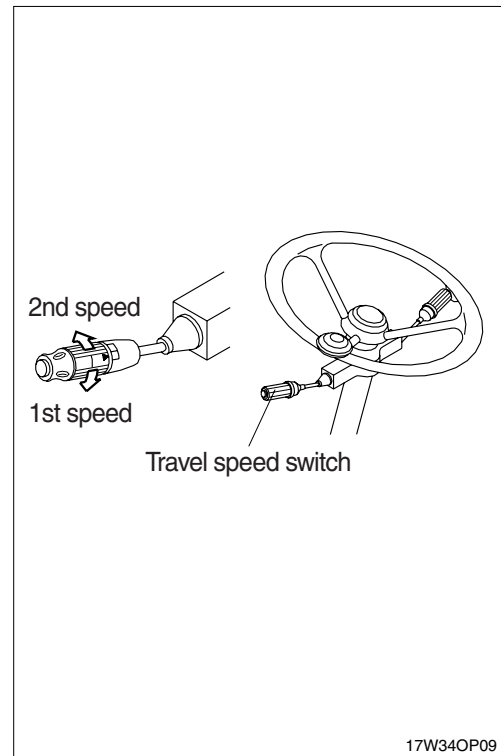

(4) Changing direction(Forward/diverse)

- ① It is possible to change direction(Forward/reverse) without stopping the machine.
 - ② Put the levers to the desired position to change direction.
- ※ When changing direction, check beforehand there is no obstacle in the direction you will be headed.
 - ※ Avoid changing direction at high speed.

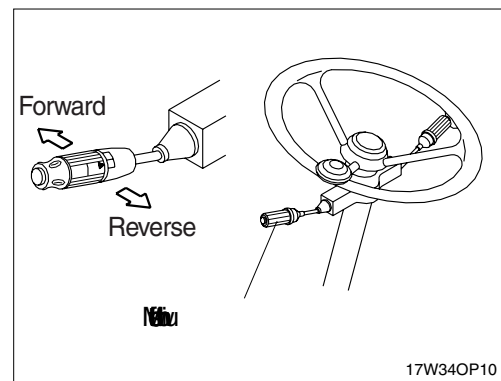

(5) Turning the machine

- ① Turn the machine by moving the steering wheel into the desired direction.
 - ② You can turn the machine to the left or right.
- ※ **Do not turn the machine abruptly when traveling at high speed and avoid turn on a slope.**
 - ※ **Steering does not function with engine OFF.**

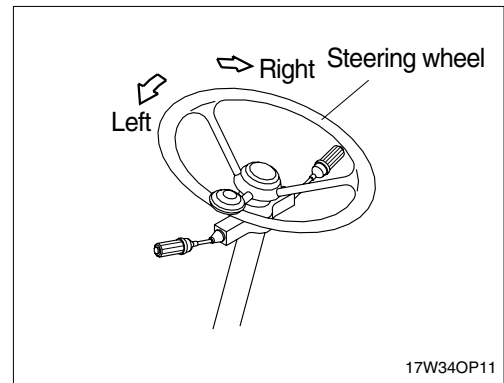

(6) Precautions when driving

The operators must be familiar with the following precautions including general safety hints.

- ① If the warning lamp lights up on the cluster and warning indicator, stop the machine immediately and check carefully whether the relevant parts are out of order or not.
- ② Do not allow the engine to run at overload. Stop the engine and check as soon as finding out abnormal noise or smell. Check the gauges frequently. Do not allow passengers or riders on the machine while it is running or in operation. Never get on or off the machine while it is moving.

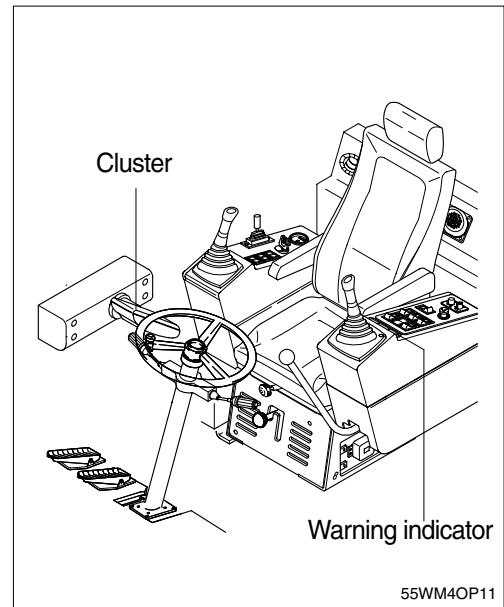

2) TRAVELING ON A SLOPE

- (1) Never travel down a slope in neutral.
 - (2) Lower the bucket 20 to 30cm(1ft) to the ground so that it can be used as a brake in an emergency.
 - (3) If the machine starts to slide or loses stability, lower the bucket immediately and brake the machine.
 - (4) When parking on a slope, use the bucket as a brake and place blocks behind the tires to prevent sliding.
- ※ **Machine cannot travel effectively on a slope when the oil temperature is low. Do the warming-up operation when it is going to travel on a slope.**
 - ※ **Be careful when working on slopes. It may cause the machine to lose its balance and turn over.**

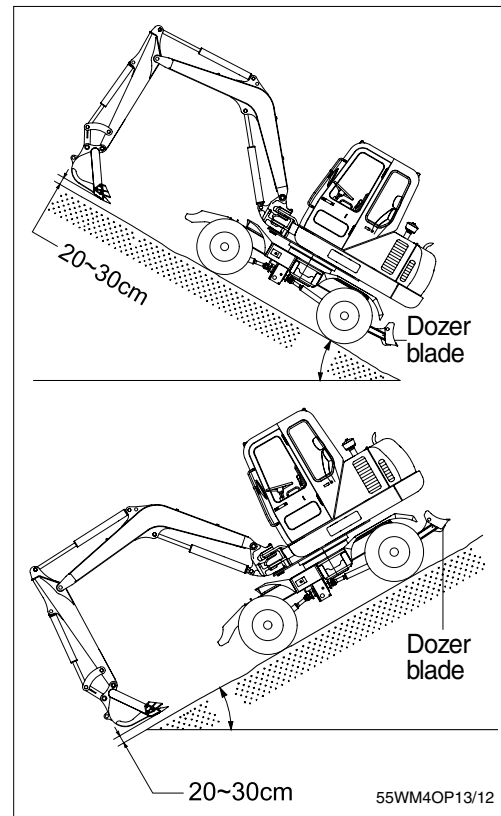

3) PARKING THE MACHINE

To park the machine, keep the steps below.

- (1) Release the acceleration pedal slowly.
 - (2) Depress the brake pedal.
 - (3) Place the forward/backward lever in the neutral.
 - (4) Put the parking switch in the parking position and release the brake pedal.
 - (5) Lower the bucket and dozer blade to the ground.
 - (6) Stop the engine, place the start key switch in the OFF and remove the key.
 - (7) Lock the swing lock lever and the cab door.
- ※ **Whenever parking on a slope, always block the tires after lowering the bucket to the ground.**

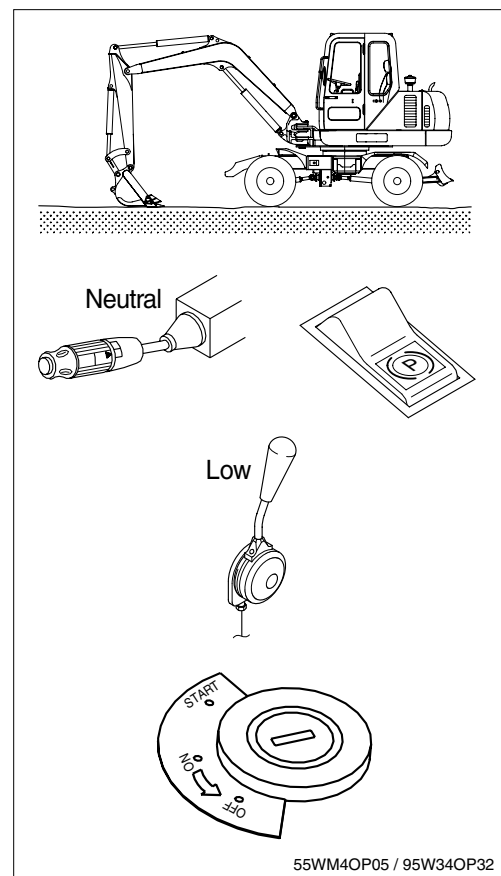

4) TOWING THE MACHINE

Except for an emergency, do not tow this machine.
If it is inevitable to tow this machine, observe the following.

(1) General

- ① Parking brake cylinder of the machine is operated by the spring force and released by hydraulic pressure.

If the engine does not operate, the brake will be operated to stop the machine.

- ② When the machine is towed move it for a repair to nearby place at the low speed.

Transport it on a trailer, if it has to be moved for a long distance.

- ③ When the steering device and the brake of the machine to be towed can not be operated, transport by trailer.

▲ Injury or death could result if a disabled machine is towed incorrectly.

▲ If your machine is towed by another machine, ALWAYS use a wire rope with a sufficient towing capacity.

▲ NEVER allow a disabled machine to be towed on a slope.

▲ When connecting up a towing machine, do not let anyone enter the area between the towing machine and the equipment being towed.

Set the towing machine and the towing

▲ connection of the equipment being towed in a straight line when connecting it.

Never tow machine using a light-duty towing

▲ hook.

5) PRECAUTIONS FOR OPERATION

(1) Permissible water depth

- ① Do not immerse the machine in water by more than the permissible depth(axle center).
- ② For parts that have been immersed in water for a long time, pump in grease until the old grease comes out from the bearings.

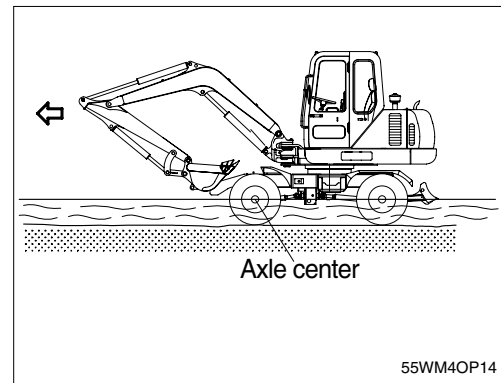

(2) When the brake does not operate

- ① If the machine does not stop even though the brake pedal is applied, use the parking brake to activate the emergency brake by parking switch.
- ※ After using the parking brake as an emergency brake, ask Hyundai dealer to check complete brake system.
 - ▲ Never use emergency brake, except when the service brake fails.

