

2. SPECIFICATIONS

1. MAJOR COMPONENT

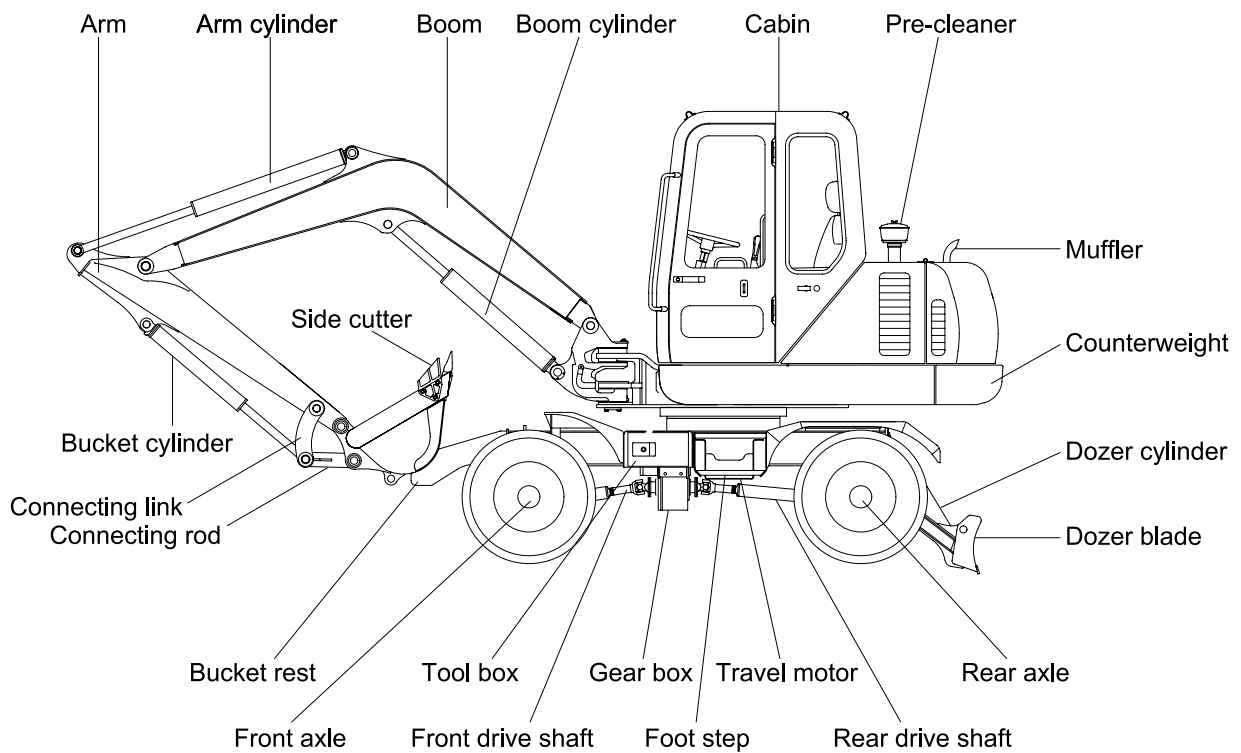
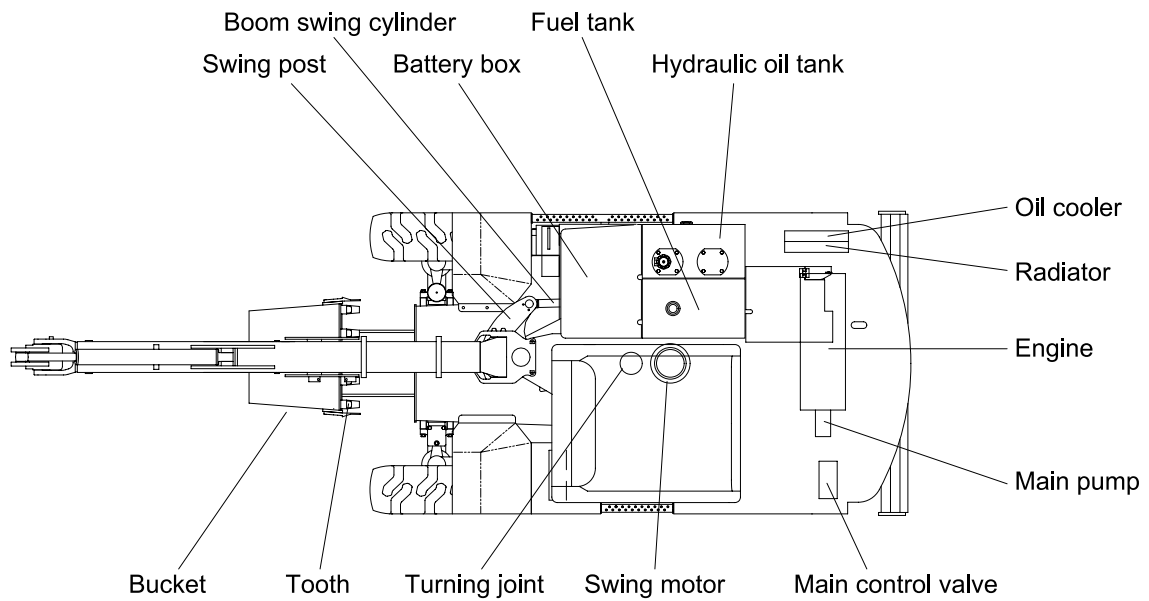

55W32SP01