

3. STARTING AND STOP THE ENGINE

1) CHECK INDICATOR LIGHTS

- (1) Check if all the operating lever is on the neutral position.
 - (2) Turn the starting switch to the ON position, and check following.
 - ① If all the lamps light ON and buzzer sounding for 6 seconds.
 - ② Only below lamps will light ON and all the other lights will turn OFF after 2 seconds.
 - Battery charging warning lamp (2)
 - Engine oil pressure warning lamp (1)
 - ③ The preheat pilot lamp (3) will light ON when the coolant temperature is below 10°C .
 - ④ The warming up pilot lamp (4) will light ON when the coolant temperature is below 30°C .
- ※ If the ESL function is set to the YES, enter the password to start engine.
- ※ If the password has failed 5 times, please wait 30 minutes before re-attempting to enter the password.
- ※ Refer to page 3-8 for the ESL function.

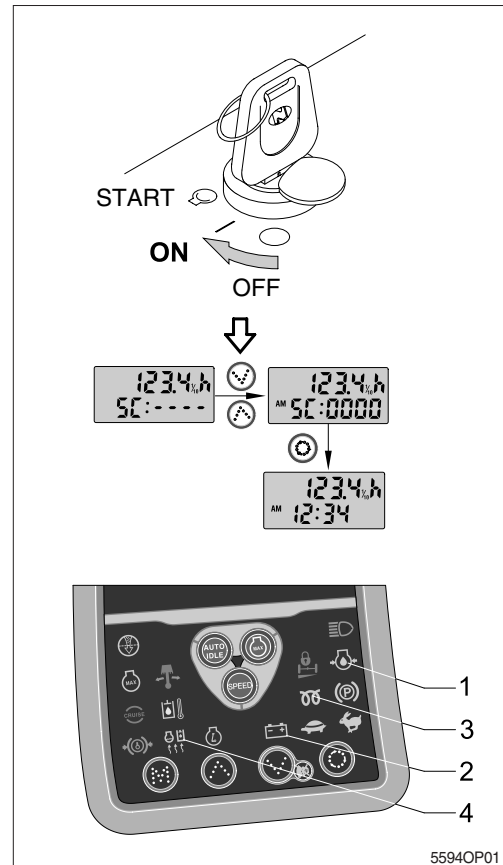

2) STARTING ENGINE

- ※ Sound horn to warn surroundings after checking if there are obstacles in the area.
- ※ Replace the engine oil and fuel referring to recommended oils at page 2-12.
- ※ Fill anti-freeze solution to the coolant as required.

- (1) Check if all levers are on the neutral position.
- (2) Turn the starting switch to ON position.
- (3) Check if the preheat pilot lamp (1) is turned ON.
 - ※ **When the preheat pilot lamp is turned ON, the preheating function is actuated within 15 seconds.**
 - ※ **After the preheat pilot lamp is turned OFF, engine start within 10 seconds.**
- (4) Start engine by turning the starting switch to the START position.
- (5) Release the starting switch immediately after starting engine to avoid possible damage to the starting motor.
 - ※ **If the engine is started before the preheat pilot lamp goes OFF, it keeps the lamp ON within 15 seconds even after the engine is started.**
 - ※ **Be aware that battery can be easily discharged after long time with head light, work lamp and air-conditioner turned on together under the condition of the low engine rpm.**

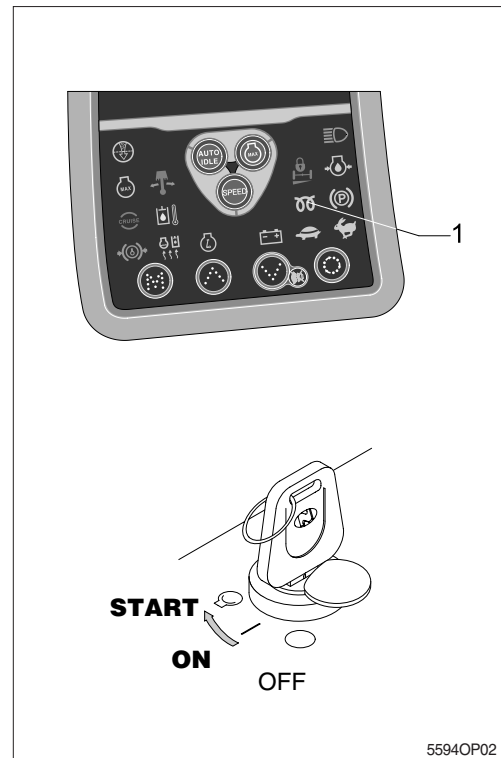

5594OP02

3) INSPECTION AFTER ENGINE START

Inspect and confirm the following after engine starts.

- (1) Is the level gauge of hydraulic oil tank in the normal level?
- (2) Are there leakages of oil or water?
- (3) Are all the warning lamps OFF (2~7)?
- (4) Is the indicator of engine coolant temperature gauge (1) in the normal zone?
- (5) Is the engine sound and the color of exhaust gas normal?
- (6) Are the sound and vibration normal?

- ※ **Do not increase engine speed quickly after starting, it can damage engine or turbocharger.**
- ※ **If there are problems in the control panel, stop the engine immediately and correct problem as required.**

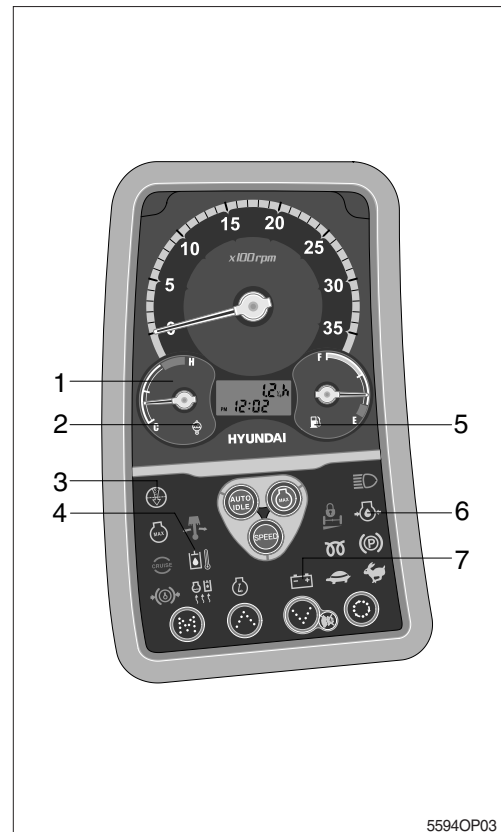

5594OP03

4) WARMING-UP OPERATION

- ※ The most suitable temperature for the hydraulic oil is about 50°C (122°F). It can cause serious trouble in the hydraulic system by sudden operation when the hydraulic oil temperature is below 25°C (77°F). Then temperature must be raised to at least 25°C (77°F) before starting work.

- (1) Run the engine at low idling for 5 minutes.
- (2) Speed up the idling and run the engine at mid-range speed.
- (3) Operate bucket lever for 5 minutes.
 - ※ **Do not operate anything except bucket lever.**
- (4) Run the engine at the high speed and operate the bucket lever and arm lever for 5-10 minutes.
 - ※ **Operate only the bucket lever and arm lever.**
- (5) This warming-up operation will be completed by operation of all cylinders several times, and operation of swing and traveling.
 - ※ **Increase the warming-up operation during winter.**

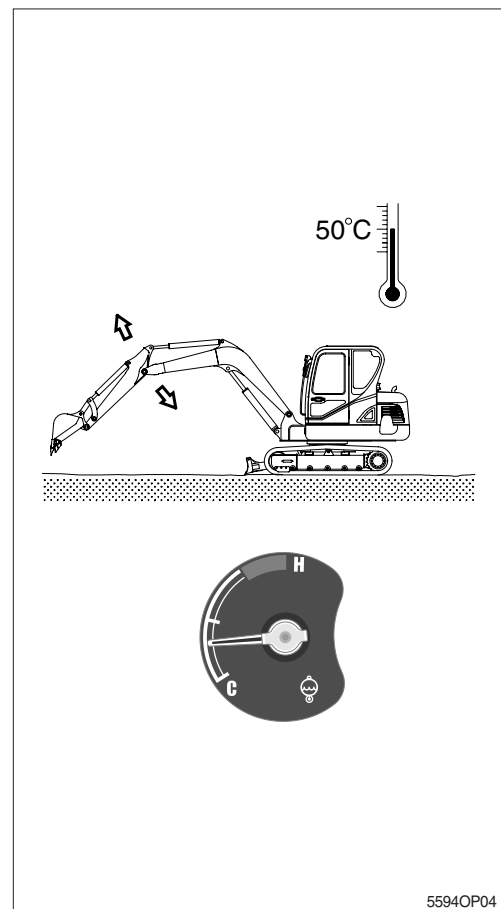

5594OP04

5) TO STOP THE ENGINE

- ※ If the engine is abruptly stopped before it has cooled down, engine life may be greatly shortened. Consequently, do not abruptly stop the engine apart from an emergency.
 - ※ In particular if the engine has overheated, do not abruptly stop it but run it at medium speed to allow it to cool gradually, then stop it.
- (1) Down the bucket on the ground then put all the levers in the neutral position.
 - (2) Run the engine at low idling speed for about 5 minutes.
 - (3) Return the key of starting switch to the OFF position.
 - (4) Remove the key to prevent other people using the machine and LOCK safety lever.
 - (5) Lock the cab door.

