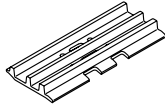
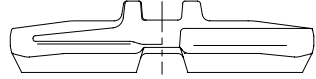

7. UNDERCARRIAGE

1) TRACKS

X-leg type center frame is integrally welded with reinforced box-section track frames. The design includes dry tracks, lubricated rollers, idlers, sprockets, hydraulic track adjusters with shock absorbing springs and assembled track-type tractor shoes with triple grousers.

2) TYPES OF SHOES

Model	Shapes		Triple grouser	
				
R55-9	Shoe width	mm (in)	380 (15)	400 (16)
	Operating weight	kg (lb)	5450 (12020)	5450 (12020)
	Ground pressure	kgf/cm ² (psi)	0.33 (4.69)	0.33 (4.69)
	Overall width	mm (ft-in)	1880 (6' 2")	1900 (6' 3")

3) NUMBER OF ROLLERS AND SHOES ON EACH SIDE

Item	Quantity
Carrier rollers	1 EA
Track rollers	5 EA
Track shoes	40 EA