

SPECIFICATIONS

1. MAJOR COMPONENT

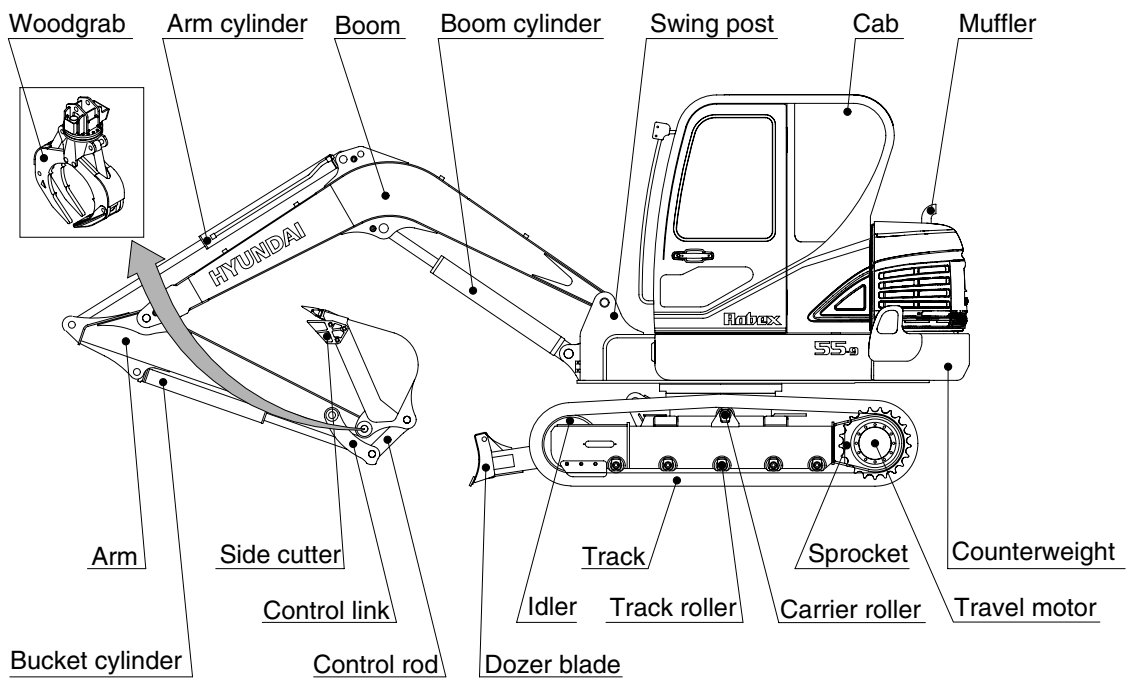
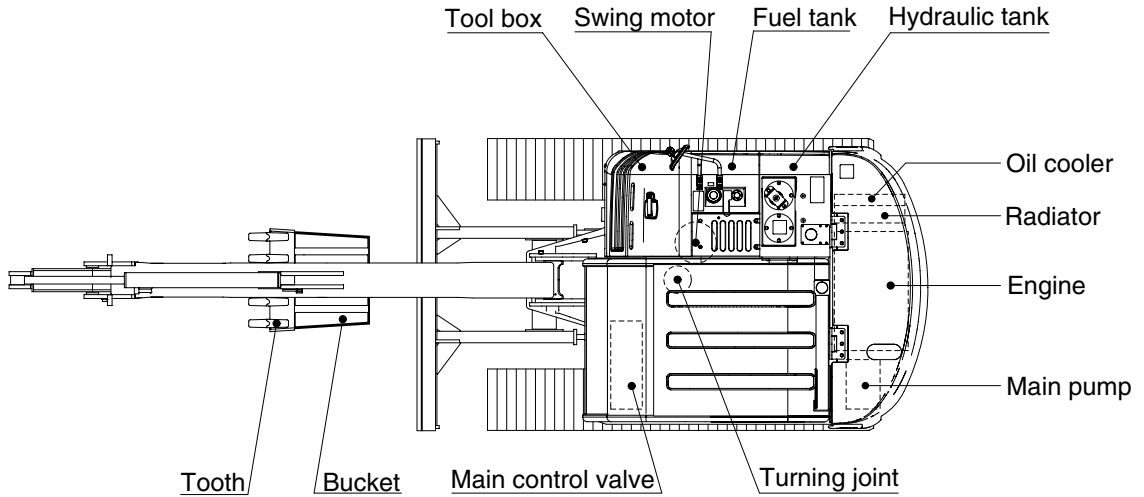

5592SP01A