

11. RCV LEVER OPERATING PATTERN

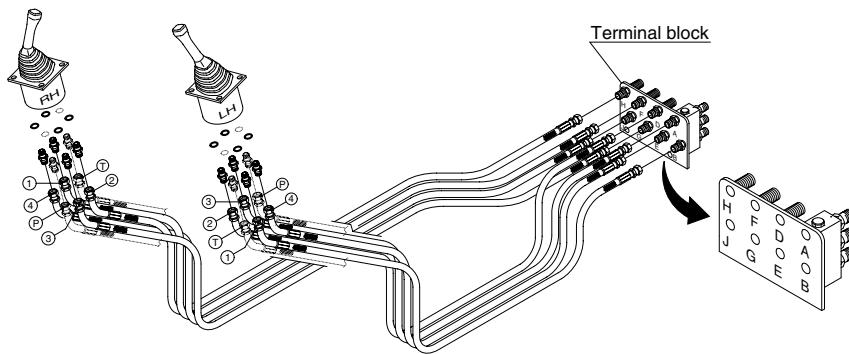

※ Whenever a change is made to the machine control pattern also exchange the pattern label in the cab to match the new pattern.

R5574OP40N

Pattern	Operation		Control function	Hose connection(Port)			
	Left	Right		RCV lever	Change of MCV port		
					From	To	
ISO Type			Left	① Arm out	②	D	-
				② Arm in	④	E	-
				③ Swing right	③	B	-
				④ Swing left	①	A	-
			Right	⑤ Boom lower	④	G	-
				⑥ Boom raise	②	F	-
				⑦ Bucket out	①	H	-
				⑧ Bucket in	③	J	-
Hyundai			Left	① Boom lower	②	D	G
				② Boom raise	④	E	F
				③ Swing right	③	B	-
				④ Swing left	①	A	-
			Right	⑤ Arm out	④	G	D
				⑥ Arm in	②	F	E
				⑦ Bucket out	①	H	-
				⑧ Bucket in	③	J	-
A Type			Left	① Boom lower	②	D	G
				② Boom raise	④	E	F
				③ Bucket in	③	B	J
				④ Bucket out	①	A	H
			Right	⑤ Arm out	④	G	D
				⑥ Arm in	②	F	E
				⑦ Swing right	①	H	B
				⑧ Swing left	③	J	A
B Type			Left	① Swing right	②	D	B
				② Swing left	④	E	A
				③ Arm in	③	B	E
				④ Arm out	①	A	D
			Right	Same as ISO type			
				Same as ISO type			
				Same as ISO type			
				Same as ISO type			
C Type			Left	① Boom lower	②	D	G
				② Boom raise	④	E	F
				③ Bucket in	③	B	J
				④ Bucket out	①	A	H
			Right	⑤ Arm out	④	G	D
				⑥ Arm in	②	F	E
				⑦ Swing right	①	H	B
				⑧ Swing left	③	J	A

RCV LEVER OPERATING PATTERN(option, A type)

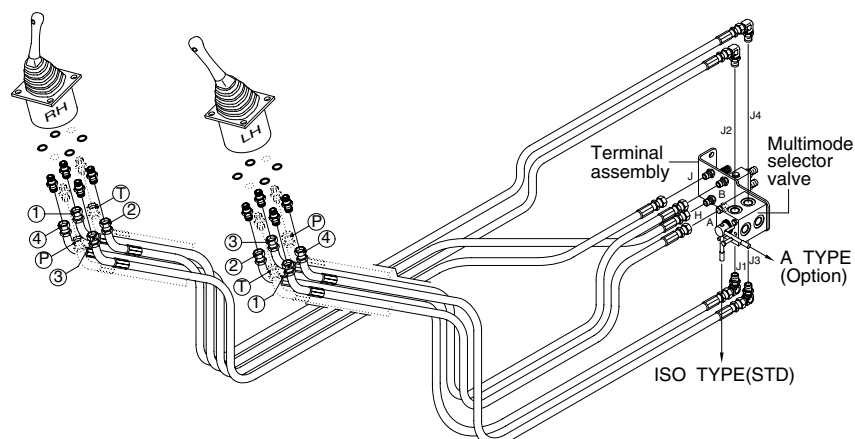

55W7A4OP91

Pattern	Operation		Control function	Hose connection(Port)			
	Left	Right		RCV lever	MCV port		
A Type			Left	① Boom lower	②	J1	
				② Boom raise	④	J3	
				③ Swing right	③	B	
				④ Swing left	①	A	
	Right				⑤ Arm out	④	J2
					⑥ Arm in	②	J4
					⑦ Bucket out	①	H
					⑧ Bucket in	③	J

1) The machine control pattern can easily be changed from the "ISO" type to the "A" type by changing the position of the lever.

▲ Before starting the machine, check the lever position of multimode selector valve and actual operating of attachment.

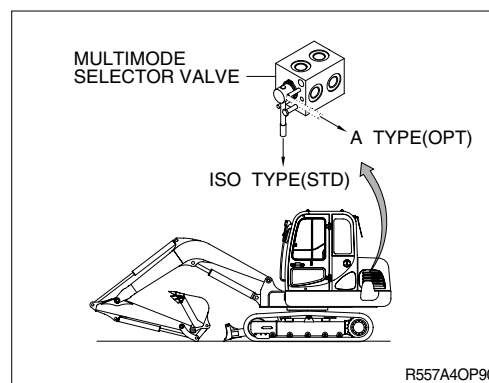

R557A4OP90

2) **Change of operating pattern(ISO → A type)**

- (1) Loosen bolt(11).
- (2) Move lever from the "ISO" type to "A" type position.
- (3) After setting the lever, tighten bolt to secure lever.

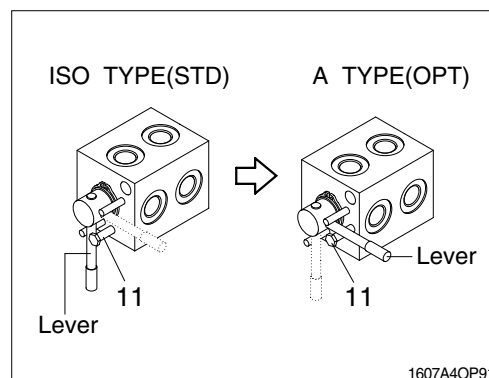

1607A4OP91