

# SPECIFICATIONS

## 1. MAJOR COMPONENT

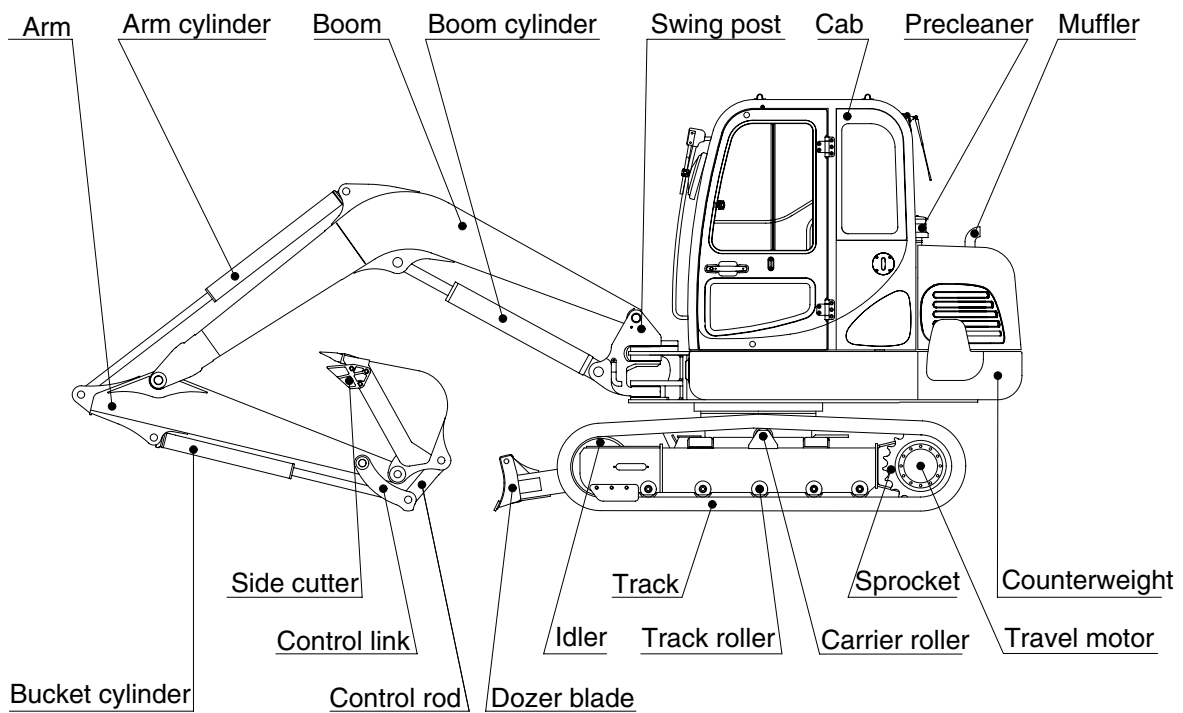
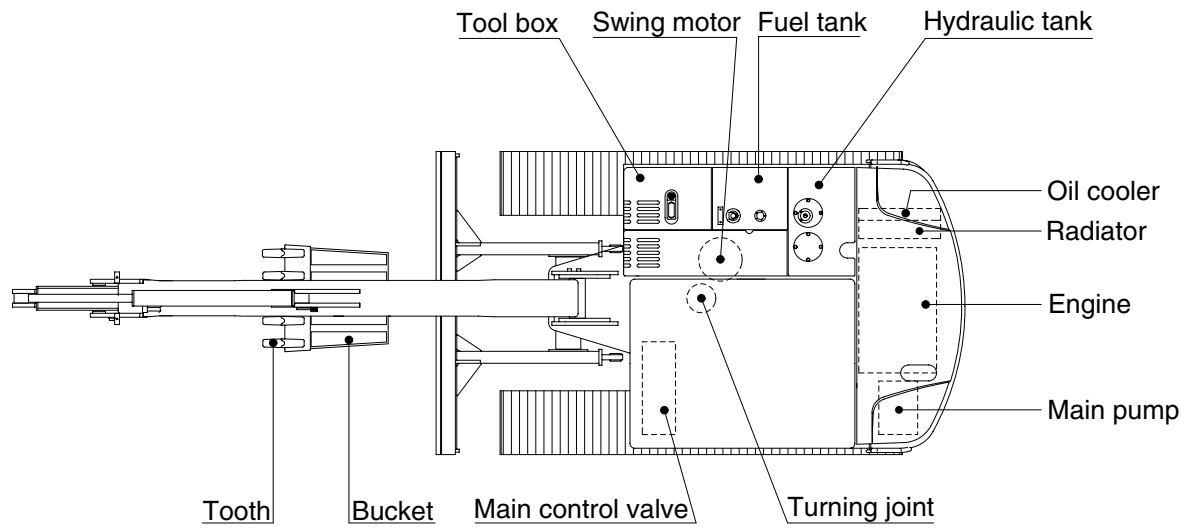

R5572SP01