

CONTROL DEVICES

1. CAB DEVICES

1) The ergonomically designed console box and suspension type seat provide the operator with comfort.

2) ELECTRONIC MONITOR SYSTEM

(1) The centralized electronic monitor system allows the status and conditions of the machine to be monitored at a glance.

(2) It is equipped with a safety warning system for early detection of machine malfunction.

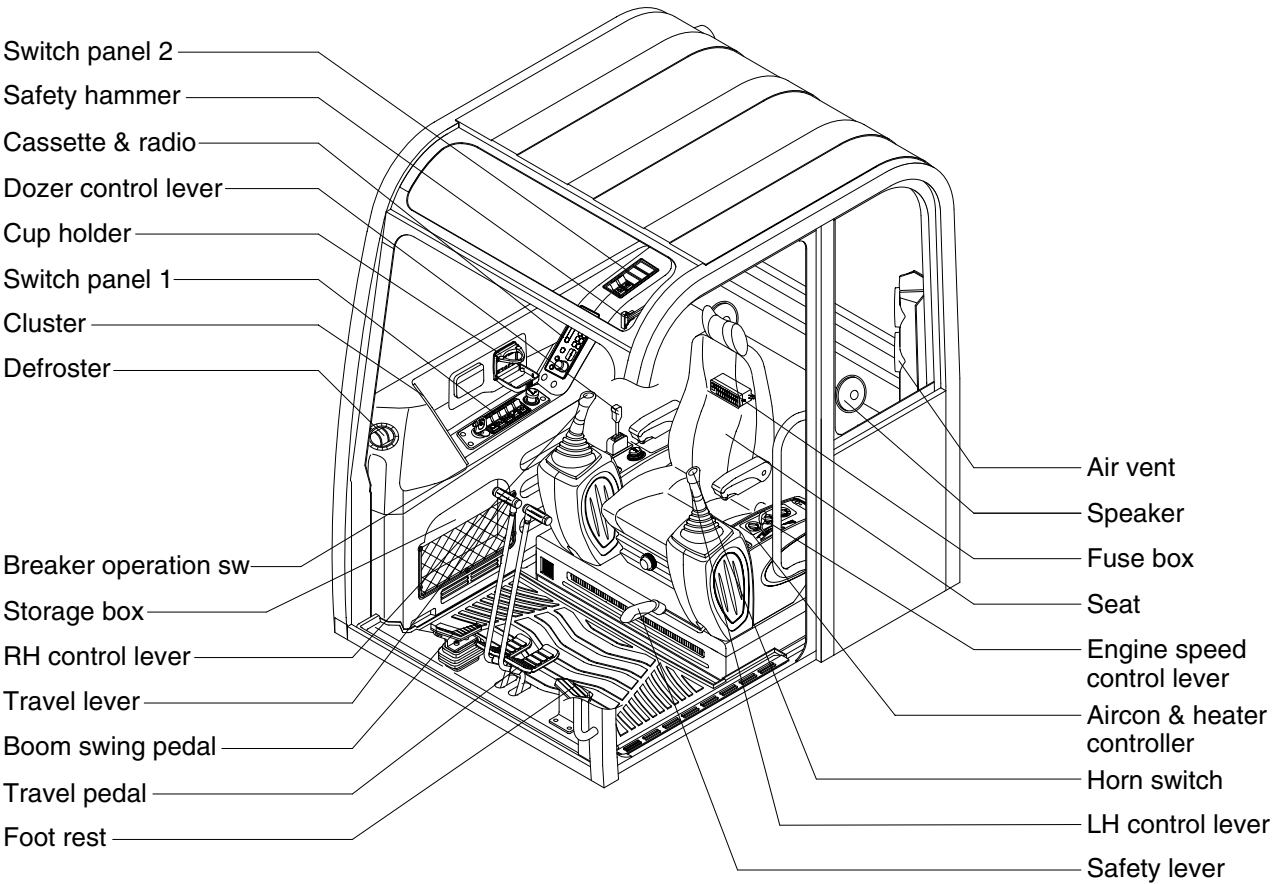

R5573CD01A

2. CLUSTER

The cluster consists of gauges and lamps as shown below, to warn the operator in case of abnormal machine operation or conditions for the appropriate operation and inspection.

- Gauges : Indicate operating status of the machine.
 - Warning lamp : Indicate abnormality of the machine(Red).
 - Pilot lamp : Indicate operating status of the machine.
- ※ **The monitor installed on this machine does not entirely guarantee the condition of the machine. Daily inspection should be performed according to chapter 6, Maintenance.**
- ※ **When the monitor provides a warning, immediately check the problem and perform the required action.**

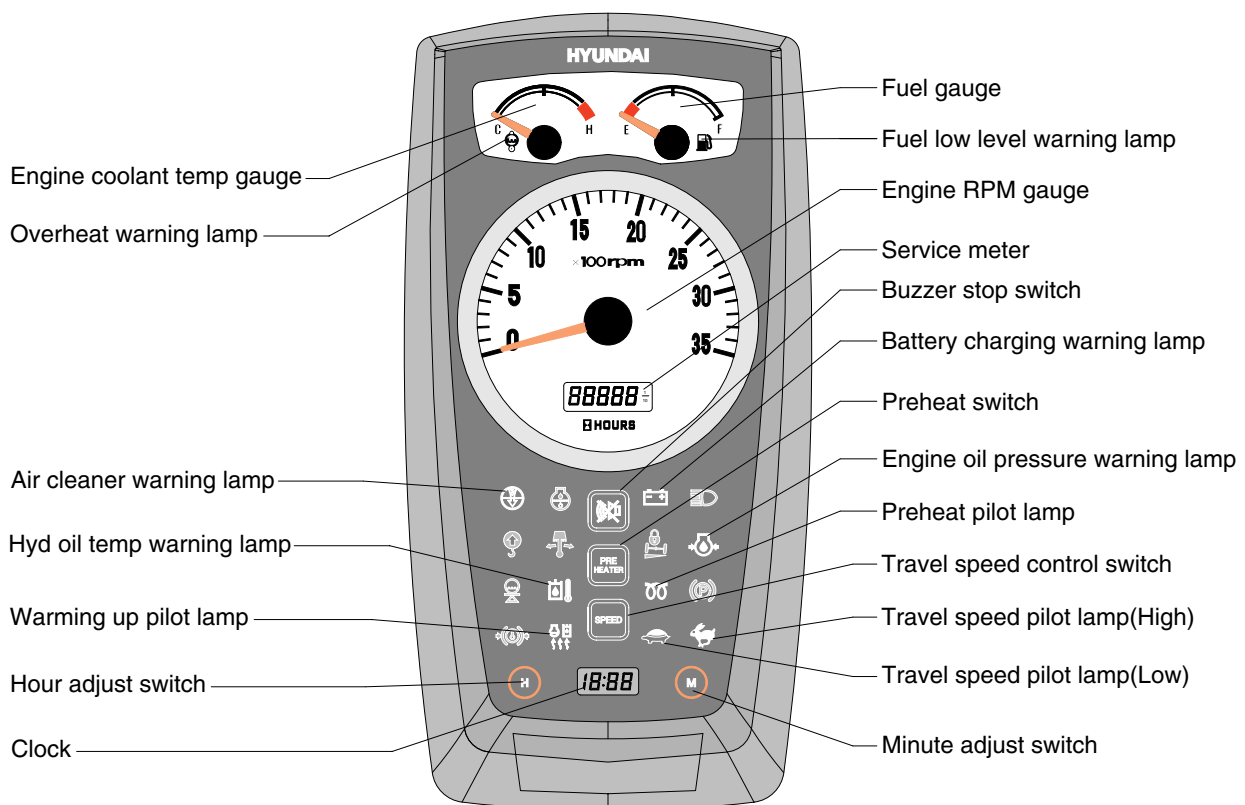

R5573CD02A

- ※ **The warning lamp lights ON and the buzzer sounds when the machine has a problem. In this case, press the buzzer stop switch and buzzer stop, but the warning lamp lights until the problem is cleared.**

1) GAUGES AND DISPLAYS

(1) Service meter





- ① This meter shows the total operation hours of the machine.
- ② Always ensure the operating condition of the meter during the machine operation.

Inspect and service the machine based on hours as indicated in chapter 6, **maintenance**.

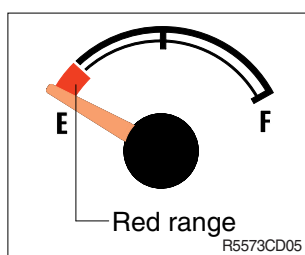
(2) Fuel gauge



- ① This gauge indicates the amount of fuel in the fuel tank.
 - ② Fill the fuel when the red range or warning lamp  ON.
- ※ If the gauge illuminates the red range or warning lamp  on even though the machine is on the normal condition, check the electric device as that can be caused by the poor connection of electricity or sensor.

(3) Engine coolant temperature gauge

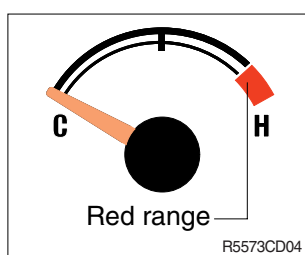

- ① This indicates the temperature of coolant.
 - Red range : Above 105°C(221°F)
 - ② When the red range pointed or warning lamp  ON, engine do not abruptly stop but run it at medium speed to allow it to cool gradually, then stop it.
Check the radiator and engine.
- ※ If the engine is stopped without cooled down running, the temperature of engine parts will rise suddenly, this could cause severe engine trouble.

(4) Engine rpm gauge

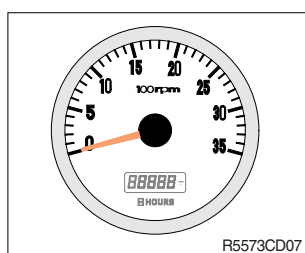

- ① This gauge displays the number of engine revolutions per minute.

(5) Clock



- ① This displays the current time.
- ② Refer to the hour/minute adjust switch for adjusting time.

2) WARNING AND PILOT LAMPS

(1) Fuel low level warning lamp



- ① This lamp blinks and the buzzer sounds when the level of fuel is below 13 l (3.4U.S. gal).
- ② Fill the fuel immediately when the lamp blinks.

(2) Hydraulic oil temperature warning lamp

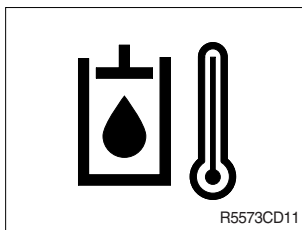

- ① This warning lamp operates and the buzzer sounds when the temperature of hydraulic oil is over 105 °C (221 °F) .
- ② Check the hydraulic oil level when the lamp blinks.
- ③ Check for debris between oil cooler and radiator.

(3) Overheat warning lamp

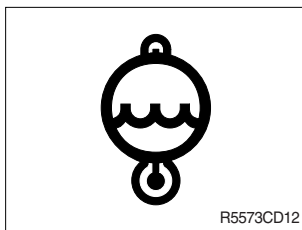

- ① This lamp blinks and the buzzer sounds when the temperature of coolant is over the normal temperature 110°C (230°F) .
- ② Check the cooling system when the lamp blinks.

(4) Engine oil pressure warning lamp

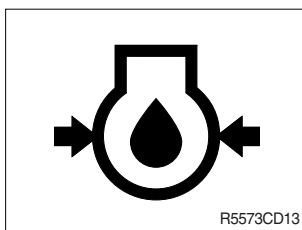

- ① This lamp blinks and the buzzer sounds after starting the engine because of the low oil pressure.
- ② If the lamp blinks during engine operation, shut OFF engine immediately. Check oil level.

(5) Air cleaner warning lamp

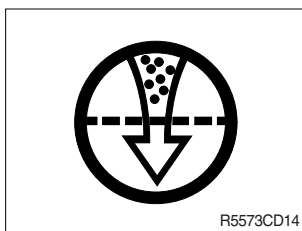

- ① This lamp blinks and the buzzer sounds when the filter of air cleaner is clogged.
- ② Check the filter and clean or replace it.

(6) Battery charging warning lamp

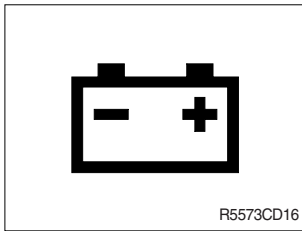

- ① This lamp blinks and the buzzer sounds when the starting switch is ON, it is turned OFF after starting the engine.
- ② Check the battery charging circuit when this lamp blinks during engine operation.

(7) Warming up pilot lamp

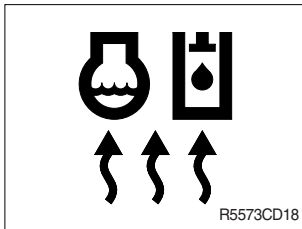

- ① This lamp is turned ON when the coolant temperature is below 30°C (86 °F).
- ② Warming up operation needed until this lamp OFF.

(8) Preheat pilot lamp

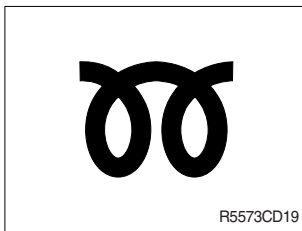

- ① When engine preheating switch is turned ON, pilot lamp comes ON.
- ② Refer to the preheating switch for details.

(9) Travel speed pilot lamp(High)

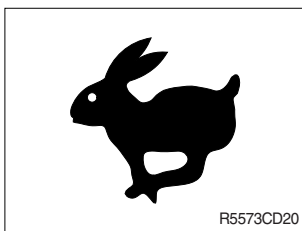

- ① When this lamp turned ON, the machine travel high speed.
- ② Refer to the travel speed select switch for details.

(10) Travel speed pilot lamp(Low)

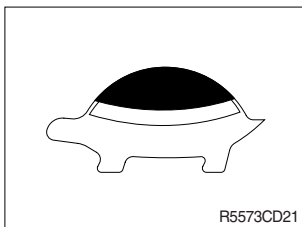

- ① When this lamp turned ON, the machine travel low speed.
- ② Refer to the travel speed select switch for details.

3) SWITCHS

(1) Travel speed control switch

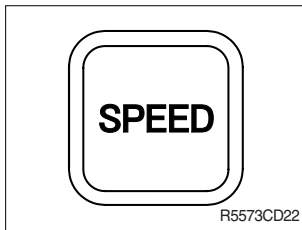

- ① This switch is to control the travel speed which is changed to high speed(Rabbit mark) by pressing the switch and low speed(Turtle mark) by pressing it again.

(2) Buzzer stop switch

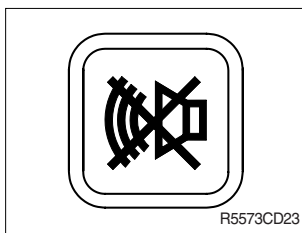

- ① When the starting switch is turned ON first, normally the alarm buzzer sounds for 6 seconds during lamp check operation.
- ② The red lamp lights ON and the buzzer sounds when the machine has a problem.
In this case, press this switch and buzzer stops, but the red lamp lights until the problem is cleared.

(3) Preheat switch

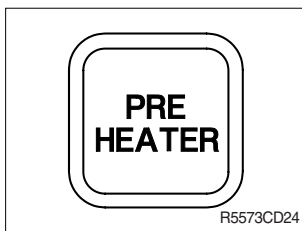

- ① In case of severe cold weather, this switch is used to preheat engine before starting.
- ② When this switch is pressed, the preheat pilot lamp is turned ON for 15 seconds in sequence and lamp OFF when the time is completed.
- ③ When the start key move to ON position, the preheat function is activated automatically under the coolant temperature is below 10° C(50° F).

(4) Hour adjust switch

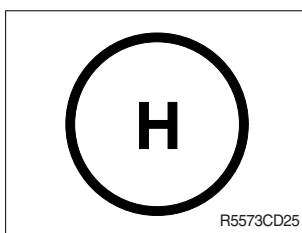

- ① This switch is used to adjust hour.
- ② The switch is pressed, hour is increased.

(5) Minute adjust switch

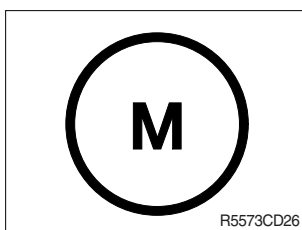

- ① This switch is used to adjust minute.
- ② The switch is pressed, minute is increased.

3. SWITCHES

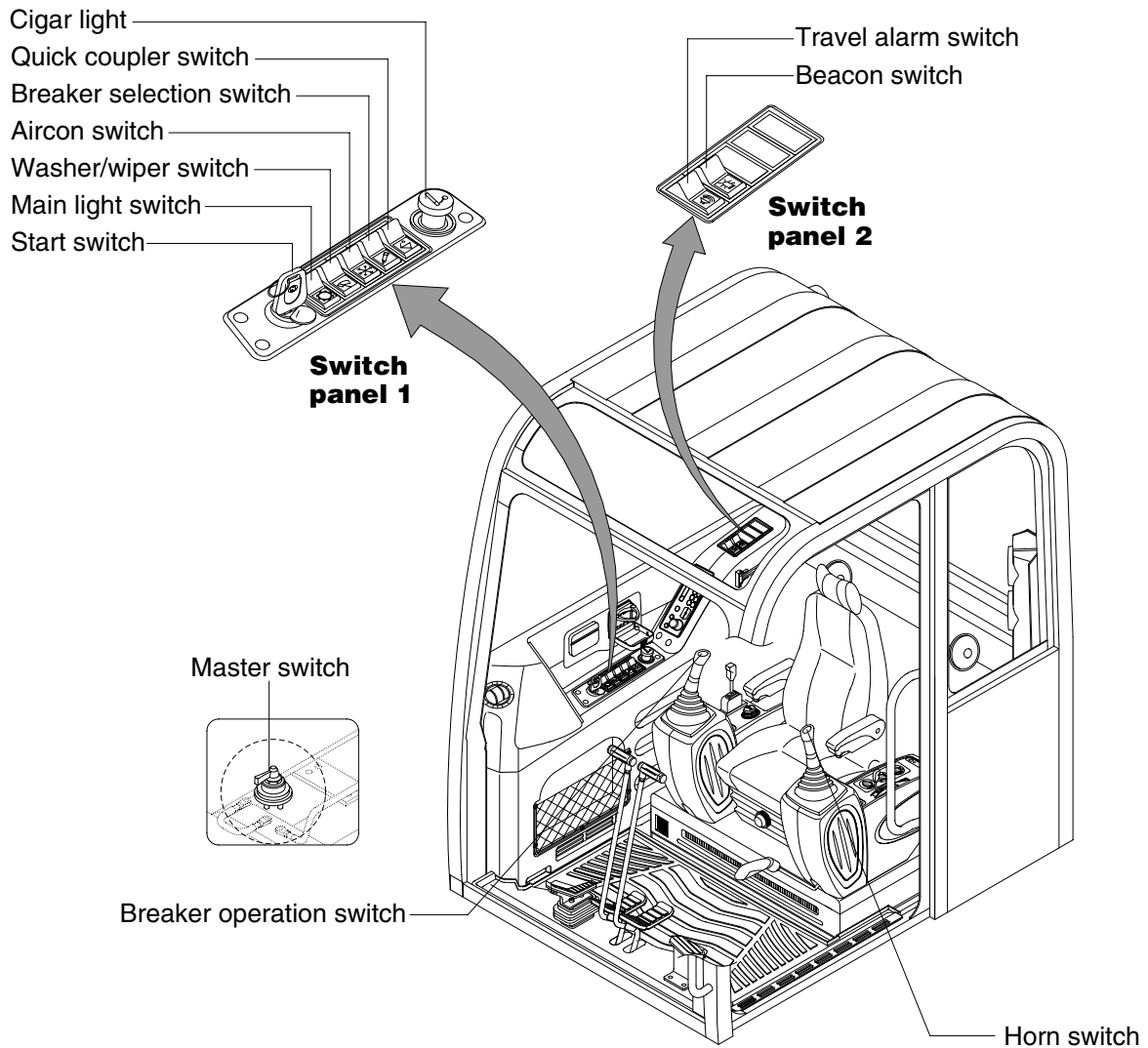

R5573CD30A

1) STARTING SWITCH

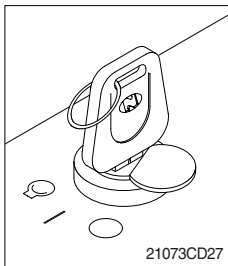

(1) There are three positions, OFF, ON and START.

- ○ (OFF) : None of electrical circuits activate.
- | (ON) : All the systems of machine operate.
- ○ (START) : Use when starting the engine. Release key immediately after starting.

※ Key must be in the ON position with engine running to maintain electrical and hydraulic function and prevent serious machine damage.

2) MAIN LIGHT SWITCH

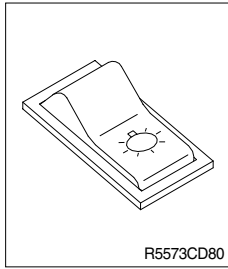

- (1) This switch use to operates the head light and work light by two step.
- First step : Head light and cluster illumination lamp comes ON.
 - Second step : Work light comes ON. Also, the below indicator lamp comes ON.

3) AIRCON SWITCH

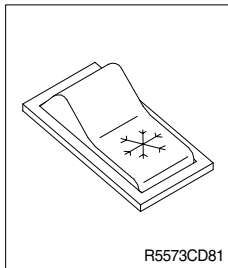

- (1) This switch use to operates the air conditioner.
- (2) Refer to the air conditioner and heater for detail operation.

4) WIPER AND WASHER SWITCH

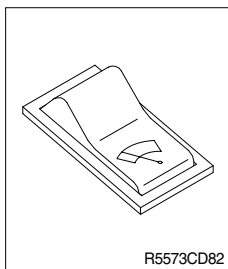

- (1) The switch use to operates the wiper and washer by two step.
- First step : The wiper operates.
 - Second step : The washer liquid is sprayed and the wiper is operated only while pressing. If release the switch, return to the first step position.

5) TRAVEL ALARM SWITCH(Optional)

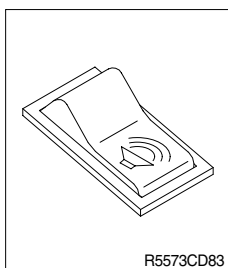

- (1) This switch is the signal to alarm surroundings when the machine travels to forward and backward.
- (2) On pressing this switch, the alarm operates only when the machine is traveling.

6) BREAKER SELECTION SWITCH(Optional)

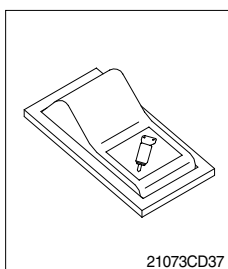

- (1) This switch is used to operates breaker.
- ※ The breaker operates only when this switch is pressed.

7) BEACON SWITCH(Optional)

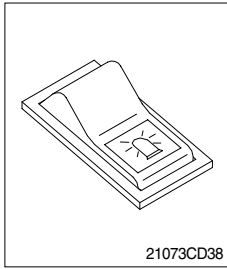

- (1) This switch turns ON the rotary light on the cab.
- (2) The below indicator lamp is turned ON when operation this switch.

8) QUICK CLAMP SWITCH(Optional)

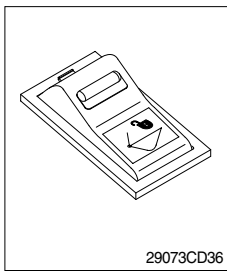

- (1) This switch is used to engage or disengage the moving hook on quick clamp.
- ※ Refer to the page 8-6 for details.

9) MASTER SWITCH

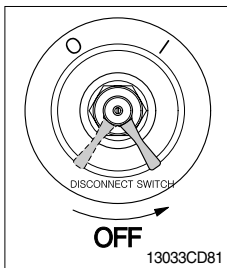

- (1) This switch is used to shut off the entire electrical system.
 - (2) I : The battery remains connected to the electrical system.
O : The battery is disconnected to the electrical system.
- ※ **Never turn the master switch to O(OFF) with the engine running. It could result in engine and electrical system damage.**

10) HORN SWITCH

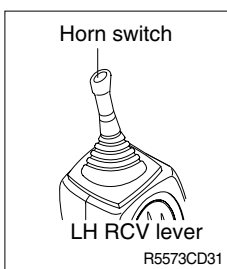

- (1) This switch is at the top of left side control lever.
On pressing, the horn sounds.

11) BREAKER OPERATION SWITCH

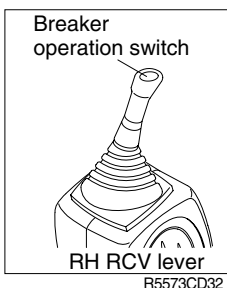

- (1) On pressing this switch, the breaker operates only when the breaker selection switch on the switch panel is selected.

4. LEVERS AND PEDALS

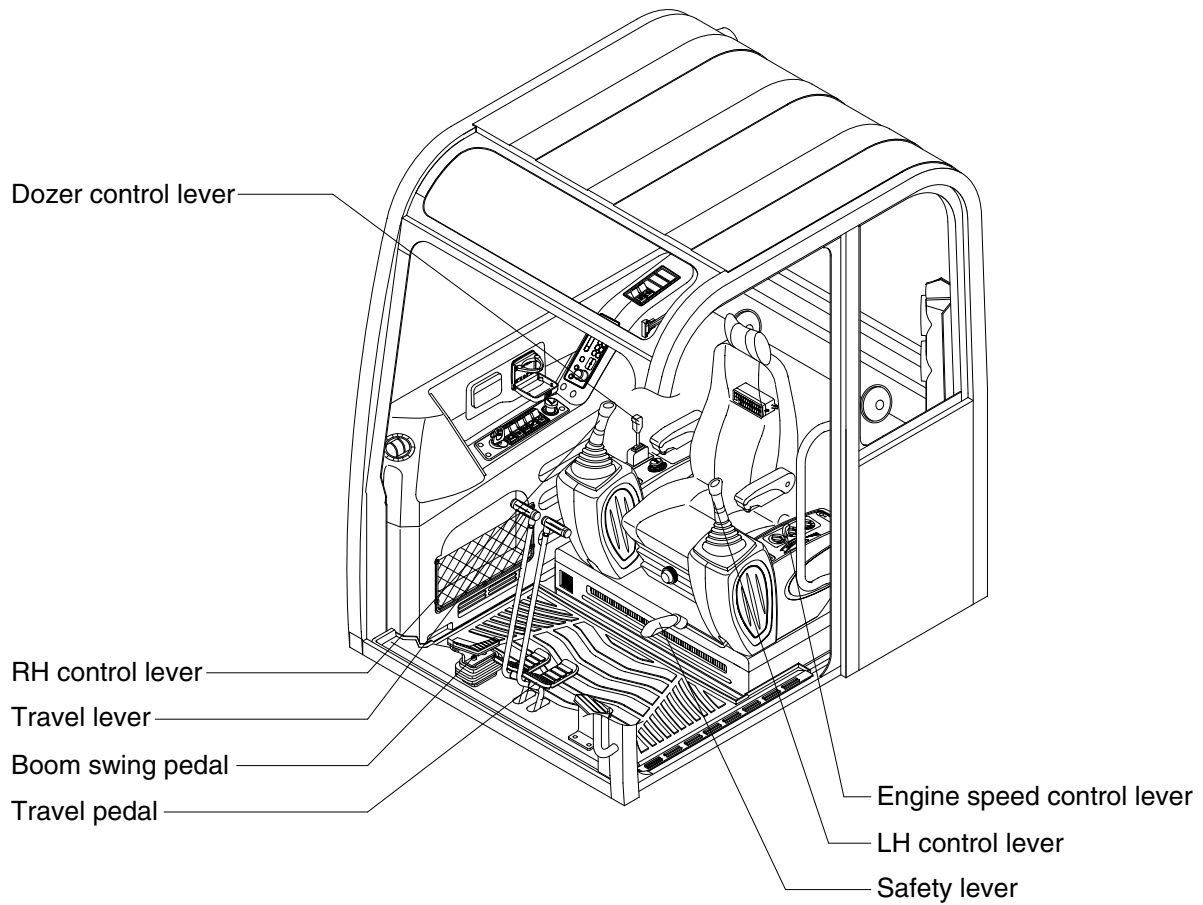

R5573CD33A

1) LH CONTROL LEVER

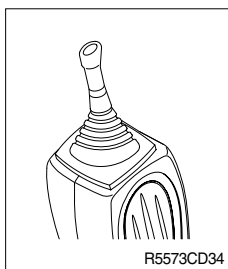

- (1) This joystick is used to control the swing and the arm.
- (2) Refer to **operation of working device** in chapter 4 for details.

2) RH CONTROL LEVER

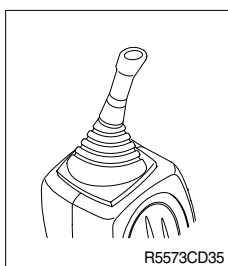

- (1) This joystick is used to control the boom and the bucket.
- (2) Refer to **operation of working device** in chapter 4 for details.

3) SAFETY LEVER

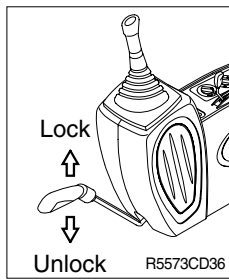

(1) LH, RH control levers, dozer control lever and travel levers with pedals are disabled from operation by locating the lever to lock position as shown.

※ **Be sure to raise the lever to LOCK position when leaving from operator's seat.**

(2) By pushing lever to UNLOCK position, machine is operational.

※ **Do not use the safety lever for handle when getting on or off the machine.**

▲ **Up to serial No. #1735**

The machine is able to travel even when the safety lever is in the LOCK position.

4) TRAVEL LEVER

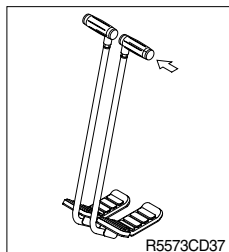

(1) This lever is mounted on travel pedal and used for traveling by hand. The operation principle is same as the travel pedal.

(2) Refer to **traveling of the machine** in chapter 4 for details.

5) TRAVEL PEDAL

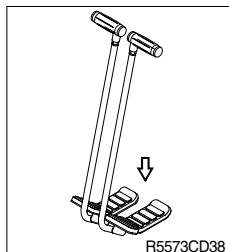

(1) This pedal is used to move the machine forward or backward.

(2) If left side pedal is pressed, left track will move.

If right side pedal is pressed, right track will move.

(3) Refer to **traveling of machine** in chapter 4 for details.

6) SEAT AND CONSOLE BOX ADJUST LEVER

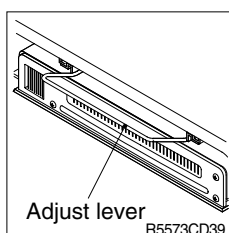

(1) This lever is used to move the seat and console box to fit the contours of the operator's body.

(2) Pull the lever to adjust forward or backward over 90mm(3.5").

7) ENGINE SPEED CONTROL LEVER

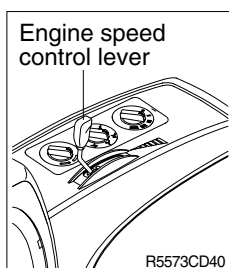

(1) This lever is used to increase or decrease the rotation speed of engine.

(2) Move the lever backward to increase engine RPM. Move the lever forward to decrease engine RPM.

(3) When stopping the engine, move the engine speed control lever forward completely and turn key OFF.

8) DOZER CONTROL LEVER

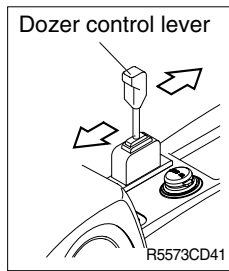

- (1) This lever is used to operate the dozer blade.
- (2) If the lever is pushed forward, the dozer blade will be going down.
If the lever is pulled back, the dozer blade will be going up.

9) BOOM SWING PEDAL

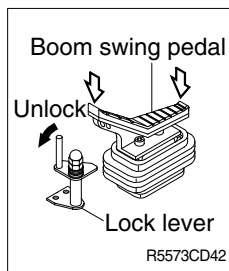

- (1) This lever is used to swing the boom to the right and left direction.
- (2) Move the lock lever to unlock position by foot.
- (3) The pedal is pressed to front side, boom will move to the left direction.
The pedal is pressed to rear side, boom will move to the right direction.

5. AIR CONDITIONER AND HEATER

Air conditioner and heater are equipped for pleasant operation against outside temperature.

- Location of air flow ducts

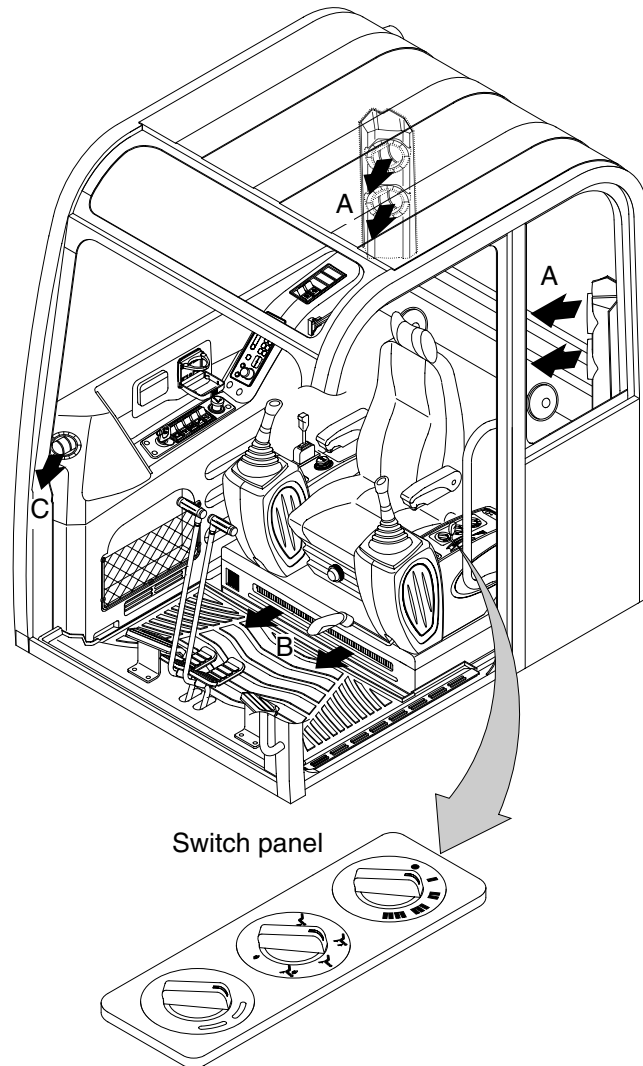

R5573CD45

1) FAN SWITCH

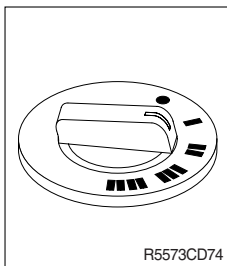

R5573CD74

It is possible to control the fan to four steps.

-  : Low
- : Medium-Low
-  : Medium-High
-  : High

2) OUTLET CHANGE OVER SWITCH

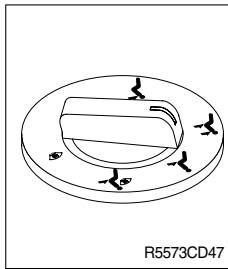

Switch position		Mode				
Outlet	A		●	●		
	B	●		●	●	
	C				●	●

3) TEMPERATURE CONTROL SWITCH

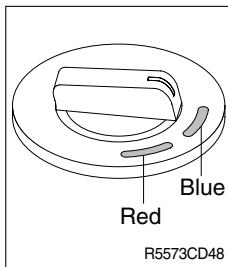

(1) Cooling (Air conditioner switch : ON)

- ① Turned ON the air conditioner switch on the switch panel.
- ② Turn the control switch into **blue range** to decrease output air temperature.

(2) Heating (Air conditioner switch : OFF)

- ① Turned OFF the air conditioner switch on the switch panel.
- ② Turn the control switch into **red range** to increase temperature.

4) OUTLET CONTROL LOUVER

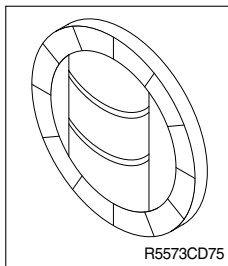

The direction of air can be controlled.
It can be closed or opened.

6. OTHERS

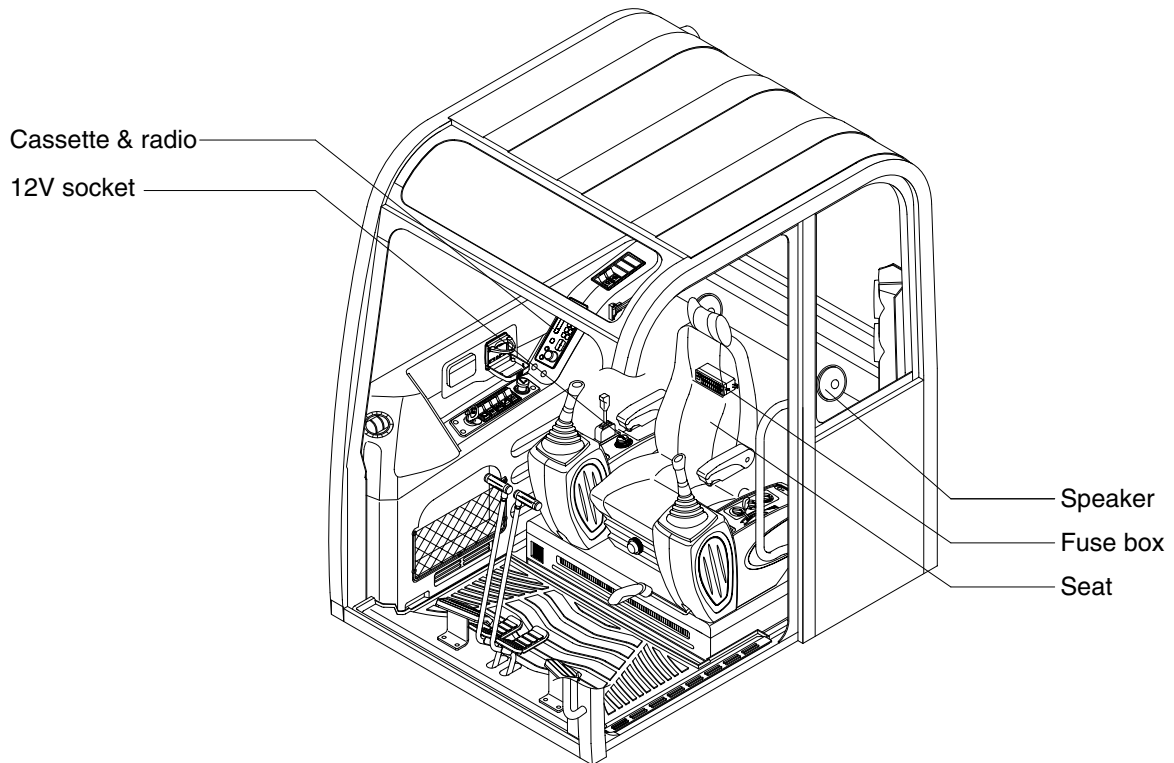

R5573CD50

1) CASSETTE AND RADIO(~#1450)

High performance audio system is equipped for pleasant operation.

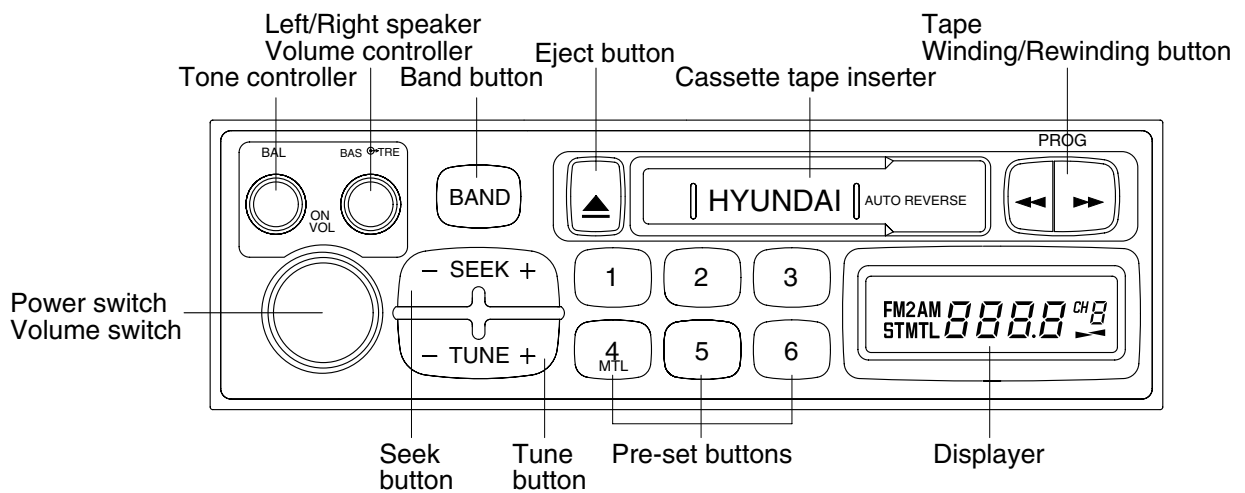

20W03CD08

(1) Power and volume switch

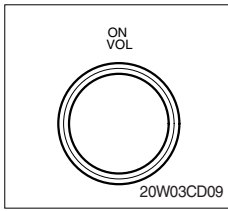

- ① This switch is turned to right, power will be turned ON and the sound is increased.
 - ② If it is turned to left, volume will be decreased and power will be turned OFF.
- ※ **The volume controller of the cassette radio does not operate when turning ON the remote controller power.**

(2) Seek button

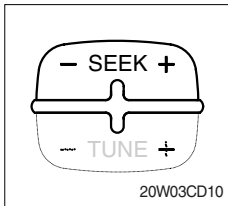

- ① If this seek button is pressed, the radio automatically stops at the next frequency of broadcasting for your listening.

(3) Tune button

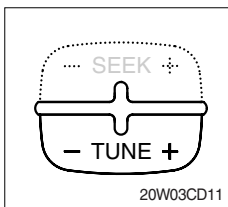

- ① Whenever you press " + " button, higher channels are selected.
- ② Whenever you press " - " button, lower channels are selected.
- ③ **General**
AM band : Frequency changes in 9kHz between 531 to 1602kHz.
FM band : Frequency changes in 0.1MHz between 87.5 to 108.0MHz.
- ④ **America**
AM band : Frequency changes in 10kHz between 530 to 1710kHz.
FM band : Frequency changes in 0.2MHz between 87.9 to 107.9MHz.
- ⑤ **Europe**
LW band : Frequency changes in 9kHz between 153 to 279kHz.
MW band : Frequency changes in 9kHz between 522 to 1620kHz.
FM band : Frequency changes in 0.05MHz between 87.5 to 108.0MHz.

(4) Pre - set button

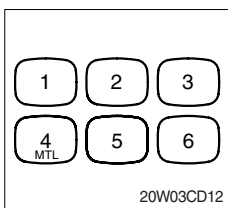

- ① You can immediately listen to the station by pressing pre-set button for which broadcasting station is pre-set.
- ② How to set broadcasting in memory.
 - You can pre-set 6 stations each AM/FM band.
 - When you want the station to be set in memory, press selected pre-set button for more than 2 seconds.

(5) Displayer

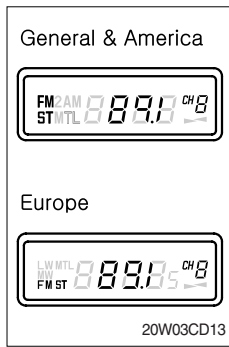

① General and America

- When radio is turned ON, stereo, AM, FM, FM2, MTL and reception frequency are displayed.

② Europe

- When radio is turned ON, stereo, LW, MW, FM, FM2, MTL and reception frequency are displayed.

③ When cassette tape is played, indicator arrow(◀ , ▶) are displayed.

(6) Left/Right speaker volume button

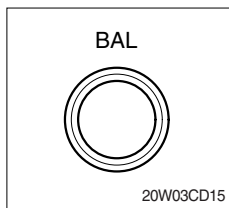

① If balance button is pressed, it will spring out.

- Volume of right and left speakers will be adjusted by turning the button to right or left.

② It will be fixed by pressing again after adjustment.

(7) Tone button

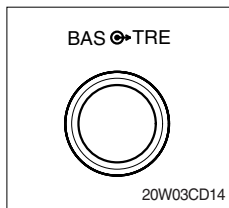

① BASS tone

- If tone button is pressed, it will spring out.

- If it is turned to right, BASS tone is increased, and if it is turned to left, BASS tone is decreased.

② TREBLE tone

- You can adjust the TREBLE tone by pull out the button.

- If it is turned to right, TREBLE tone is increased, and if it is turned to left, TREBLE tone is decreased.

③ It will be fixed by pressing again after adjustment.

(8) Band button

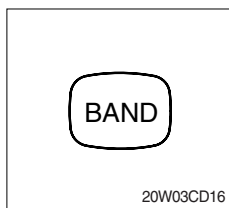

① You can listen to broadcasting on AM or FM band by pressing this band selection button.

(9) Tape winding/Rewinding button

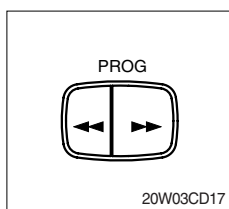

① If you press this button once while the tape is playing the direction will be reversed.

② If you press one of these buttons the tape will be winding fast or rewinding, and if you press another button on a certain point, the tape will be played.

2) SEAT

The seat is adjustable to fit the contours of the operator's body. It will reduce operator fatigue due to long work hours and enhance work efficiency.

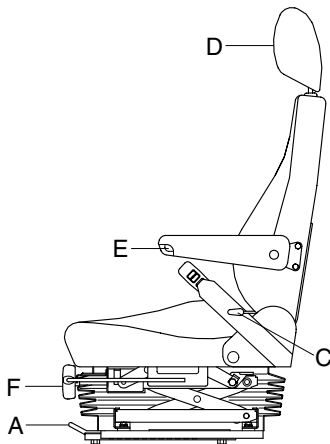
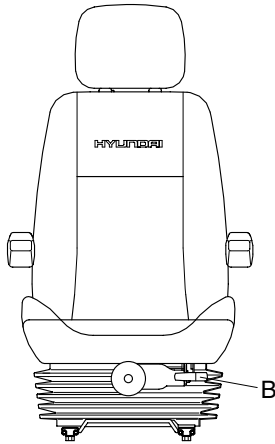

95W33CD16

(1) Forward/Backward adjustment(A)

- ① Pull lever A to adjust seat forward or backward.
- ② The seat can be moved forward and backward over 170mm(6.7") in 9 steps.

(2) Upward/Downward adjustment(B)

- ① Pull or push lever B to adjust seat upward or downward.
- ② Forward or backward side adjustment only can be made, tilting to one side, by moving lever B respectively.

(3) Reclining adjustment(C)

Pull lever C to adjust seat back rest.

(4) Arm rest adjustment(E)

This can be adjusted by rotating the dial or knob E to right and left.

(5) Head rest adjustment (D)

This is adjustable vertically and inclinedly to fit operator's requirements.

(6) Cushion adjustment (F)

Adjust the handle to the operator's weight.

▲ Always check the condition of the seat belt and mounting hardware before operating the machine.

▲ Replace the seat belt at least once every three years, regardless of appearance.

3) CIGAR LIGHTER

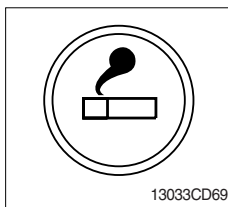

(1) This can be used when the engine starting switch is ON.

(2) The lighter can be used when it springs out in a short while after being pressed down.

※ **Service socket**

Use cigar lighter socket when you need emergency power.

Do not use the lighter exceeding 12V, 120W.

4) 12V SOCKET(Option)

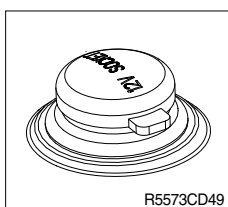

(1) Utilize the power of 12V as your need and do not exceed power of 12V, 120W.

5) FUSE BOX

HORN	10A	START KEY	20A
FUEL FILLER P/P	20A	CASSETTE ROOM LAMP	20A
CIGAR LIGHT	10A	CLUSTER	5A
SAFETY SOL	5A	CASSETTE RADIO	10A
SOLENOID	20A	CLUSTER	10A
ALT START	10A	FUEL CUT-OFF	10A
TRAVEL	10A	WIPER	10A
BEACON LAMP	10A	AIR-CON HEATER	30A
PRE-HEAT	10A	HEAD LAMP	20A
FEED P/P	5A	WORK LAMP	20A
FUSE HOLDER		SPARE	10A
		SPARE	20A

R5573CD60

(1) The fuses protect the electrical parts and wiring from burning out.

(2) The fuse box cover indicates the capacity of each fuse and circuit it protects.

※ **Replace a fuse with another of the same capacity.**

▲ **Before replacing a fuse, be sure to turn OFF the starting switch.**

6) UPPER WINDSHIELD

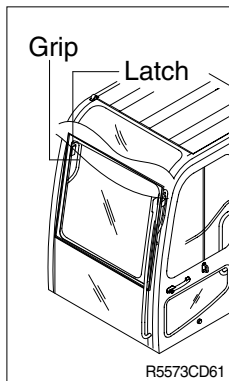

R5573CD61

(1) Perform the following procedure in order to open the upper windshield.

① Release both latches in order to release the upper windshield.

② Hold both grips that are located at both side the windshield frame push the windshield upward.

③ Hold both grips that are provided on the windshield frame and back into the storage position until auto lock latch is engaged.

(2) Perform the following procedure in order to close the upper windshield.

Reverse step ① through step ③ in order to close the upper windshield.

7) RADIO AND CASSETTE(Standard, #1451~)

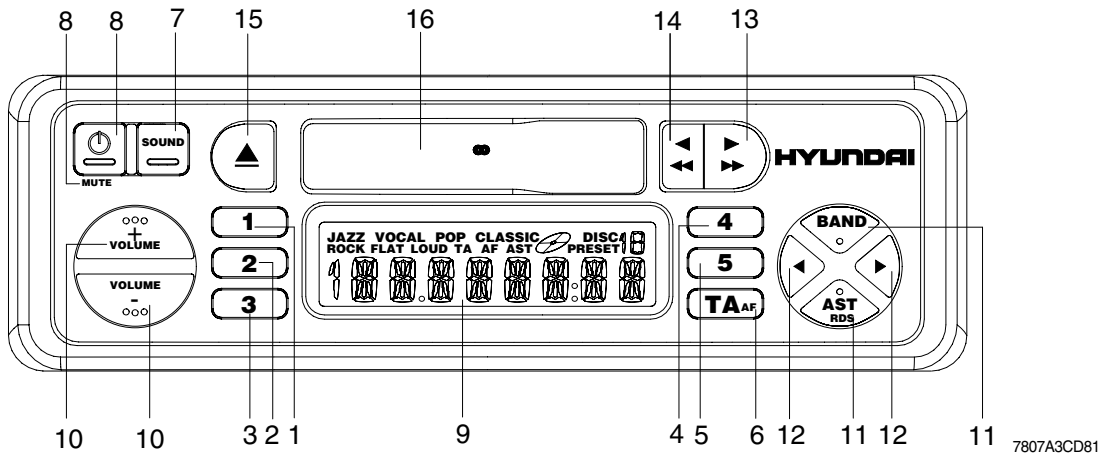

■ FRONT PANEL PRESENTATION

- | | | | | | |
|----|--------------|---|----|-------------|------------------------------------|
| 1 | 1 | Preset button 1 | 11 | RDS | Long press : RDS on/off |
| 2 | 2 | Preset button 2 | | BAND | Short press : To select band |
| 3 | 3 | Preset button 3 | | AST | Short press : Autostore |
| 4 | 4 | Preset button 4 | 12 | ◀▶ | Tuner mode |
| 5 | 5 | Preset button 5 | | | Short press : Auto search up/down |
| 6 | TA AF | Short press : TA on/off
Long press : AF on/off | | | Long press : Manual search up/down |
| 7 | SOUND | Select sound/audio styles | | | Cassette mode : No function |
| 8 | ⏻ | Short press : power on
Long press : power off | 13 | ▶▶ | Fast forward |
| | MUTE | Short press : To mute or cancel mute. | 14 | ◀◀ | Fast rewind |
| 9 | | Display | 15 | ▲ | Eject cassette |
| 10 | | Volume knob : Press up/down to
adjust the volume ; adjust selected
audio mode | 16 | | Cassette opening |

■ AUDIO

(1) Power and mute button

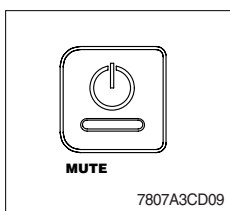

① POWER ON/OFF

Press  to switch on the set. Press  for more than 2 seconds to switch off the set.

② MUTE(Silence)

Short press  key to mute or cancel the mute(silence).

※ The silence period may be interrupted by ALARM announcement or traffic announcement messages(if TA is switched on).

(2) Volume button

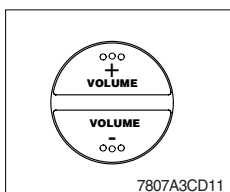

① Press the volume button up/down to adjust the volume.

Please make sure you can still hear the traffic(horns, sirens..).

(3) Sound button

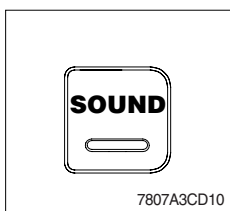

① SOUND

Whether you listen to Jazz, Vocal, Pop, Classic or Rock music, the SOUND button is the perfect setting for your choice.

- Press SOUND then the sound button to select BASS-Treb for your own sound style, or adjust the settings with the volume up/down buttons to select one of the pre define sound styles:

- BASE -TRE : Your own settings of bass and treble.
- FLAT : Original
- JAZZ : Jazz music
- VOCAL : Speech
- POP : Pop music
- CLASSIC : Classical music
- ROCK : Rock music

② AUDIO SETTING

- Press SOUND to select desired audio mode.
- Adjust the settings with the volume up/down buttons :

- Sound style : BASS-TRE, FLAT, JAZZ, VOCAL, POP, CLASSIC, ROCK
- BASS : Low notes
- TREBLE : High notes
- BALANCE : Left-right
- FADER : Rear-front
- LOUD : OFF, LOW, MID, HIGH

- Press the volume button to adjust the selected audio mode. After 5 seconds the display goes back to the last mode of operation. Adjustment of Bass and Treble settings is only possible when BASS-TRE is selected as the sound style.

■ RADIO

(1) Wave band / Automatic search button

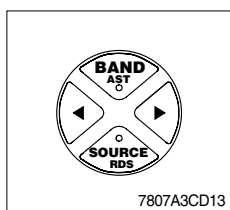

① WAVEBAND

- Press BAND to select the desired band:



② AUTOMATIC SEARCH

Use search tuning to automatically search for a station.

- Press ◀ to tune a station of a lower frequency or ▶ to a higher frequency.
- To search for another station, press the key again.

③ MANUAL TUNING(If you know the frequency of the required station)

- **To switch to manual tuning :**
Long press the search button ◀ or ▶ for more than 2 seconds will switch the tuning to manual tuning.
- Then press ◀ to tune to a station of a lower frequency or ▶ to a higher frequency.
- When keys are released, a time-out start to count. After 5 seconds time-out, display 'Auto' for one second and return to automatic search.

(2) Preselected button

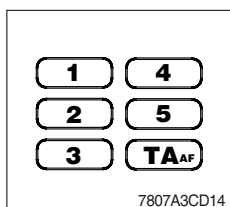

Preselected stations

① Manually storing stations in a preset

Five stations per band can be stored and recalled using the preset keys(1 to 5).

Tune in to the desired station.

- Press the desired preset key(1 to 5) for more than 2 seconds to store the current tuned station.

When storing an FM station, the current program station name and the AF mode are stored on the preset(Some stations use alternating program service name).

② Recalling a preset

Press the desired preset key(1 to 5) to recall the stored station.

③ Automatically storing stations(AUTO-STORE)

You can automatically store 5 strongest FM stations on the FM AST band or 5 strongest MW(AM) stations on the MW(AM) AST band. When you use Auto store, the new stations replace any stations previously stored in the FM AST band or the MW(AM) AST band.

- Press AST to activate autostore.
- The set gives a beep and then mutes.
- When it has finished, you hear a beep followed by the station stored on preset 1.
- Sometimes it may not be possible to find 5 stations.

■ RADIO DATA SYSTEM(RDS) ON FM

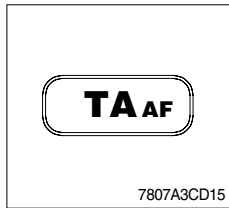

More and more stations broadcasts RDS informations in order to offer you many advantages including:

(1) Program service name(PS)

Allows the radio to display the name of the station instead of its frequency.

(2) Automatic returning(AF)

The set remains tuned to the current station by continually searching the best alternative frequency for best reception.

You can switch AF off.

- Activate/Deactivate AF

This set continuously search for other alternative frequencies for the tuned radio station and automatically selects the best frequency for reception. Long press  for more than 2 second to activate/deactivate AF.

(3) Alarm messages(PHY ALARM)

This set automatically receives emergency messages made by the broadcaster.

- During the messages the display shows 'ALARM' and the station-name alternately.

(4) Traffic announcements(TA)

You can activate the TA modes to give priority so as to hear traffic announcements related to these subjects(even if you play a cassettes/CD or mute the set).

- Activate/Deactivate TA

- Short press BAND to select an FM band.
- Press  to activate/deactivate TA.

- If you activate TA mode

- You will hear the traffic announcements when broadcast by station(even if you play a cassette/CD or mute the set).
- If the tuned station does not enable the reception of traffic announcements, the display shows 'NO TA'. The radio automatically searches and appropriate station.

- Interrupting traffic announcement mode

If you do not wish to continue listening to a particular traffic announcement

- Short press  key to interrupt traffic announcement without switching off the mode
- The set will return to the previous operating mode.

※ You can switch off RDS features if not required.

- Long press RDS key to switch off RDS.
- All RDS related features e.g., TA, etc...will be deactivated when RDS is switch off.

■ CASSETTE PLAYER

(1) Winding/Rewinding button

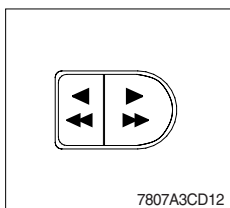

- ※ Only use good quality cassettes.
- ※ To avoid possible tape damage always take out the cassette after use. Protect your cassettes. Put them back in their boxes immediately after use.
- ※ Never expose cassettes to heat or direct sunlight.

① Play back

Slide the cassette, with the open side to the right into the cassette opening. Playback starts.

The direction of playback is shown by indicator ► .

② Stopping playback(▲)

- To stop playback, Press the ▲ button fully home.
- The unit will switch over to radio reception.
- The cassette is partially ejected.

③ Reverse(before the end of the tape)

Press the ◀◀ and ▶▶ buttons at the same time halfway in.

④ Fast rewind / Fast forward(◀◀ or ▶▶)

The direction of fast winding depends on the direction of play indicated on the display.

Display during playback	Action	Key to press
►	Fast forward	▶▶
▶	Fast rewind	◀◀
◀	Fast forward	◀◀
◀	Fast rewind	▶▶

During fast forward or rewind the radio resumes. If you continue fast winding until the end of the tape, play back restarts automatically.

⑤ To stop fast winding

To stop fast winding before the end of the tape, press the key which is not pressed(◀◀ or ▶▶). Playback is then resumed.

⑥ End of the tape

At the end of the tape, playback continues in the revers direction.

⑦ Maintenance

After extended use of the cassette player, dust, contamination or grime can accumulate on the playback head.

This results in diminishing high-note reproduction. This can be remedied using a cleaning cassette(one or twice a month) and playing it through like an ordinary cassette.

■ RADIO SETTING

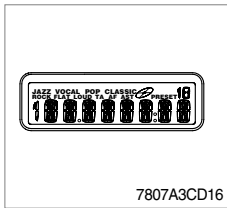

(1) AMERICA

Press  , No. 1 and No. 4 buttons at the same time. Set up completes displaying " AMERICA".

(2) SOUTH AMERICA

Press  , No. 2 and No. 5 buttons at the same time. Set up completes displaying " SOUTH".

(3) ASIA

Press  , No. 1 and No. 5 buttons at the same time. Set up completes displaying " ASIA".

(4) EUROPE

Press power, No. 2 and No. 4 buttons at the same time. Set up completes displaying " EUROP".

■ CD PLAYER

(1) Winding / Rewinding button

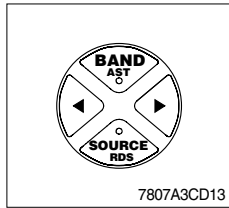

① CD playback

This CD player is suitable only for 12cm disc, do not use irregular shaped CD.

- Slide the disc into the slot with label facing upwards. Playback starts.
- If a disc is already inserted :
Press SOURCE to select CD as the source.
Playback starts.

② Previous / Next track(◀ or ▶)

- Short press the ◀ or ▶ button to select the desired track.
- Playback resume with the chosen track.

③ Fast rewind / Fast forward(◀◀ or ▶▶)

- Long press the ◀◀ or ▶▶ button for more than 2 seconds to quickly move rewind or forward through the disc.
- Normal play back resumes when you release the button.

④ Random track playback

- Press RND to activate / deactivate random track playback.

⑤ Repeat track

- Press RPT to activate / deactivate repeat current track.

⑥ Scan track

The scan function enables you to listen to the first few seconds of each track.

- Press SCN to activate / deactivate scan track.

⑦ Disc eject

- Press ▲ to eject the disc.

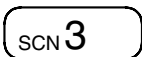
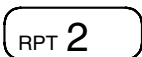
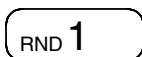

■ RADIO SETTING

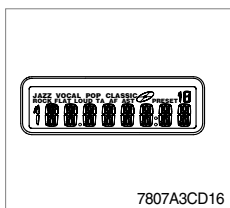

(1) AMERICA

Press , No. 1 and No. 4 buttons at the same time. Set up completes displaying " AMERICA".

(2) SOUTH AMERICA

Press , No. 2 and No. 5 buttons at the same time. Set up completes displaying " SOUTH".

(3) ASIA

Press , No. 1 and No. 5 buttons at the same time. Set up completes displaying " ASIA".

(4) EUROPE

Press power, No. 2 and No. 4 buttons at the same time. Set up completes displaying " EUROP".

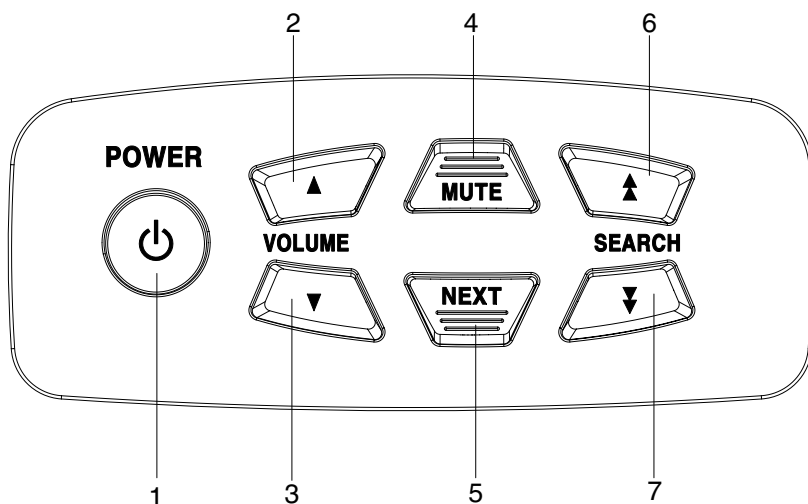

8) REMOTE CONTROLLER

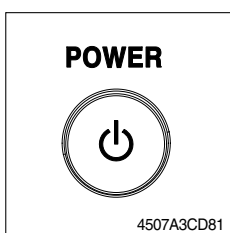

4507A3CD90

(1) Power ON/OFF button



① Press  to switch ON the set. Press  for more than 2seconds to switch OFF the set.

(2) Volume button(up)

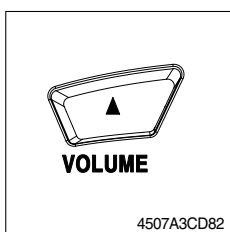

- Short press : Volume up one step
- Long press : Volume up continuous

(3) Volume button(down)

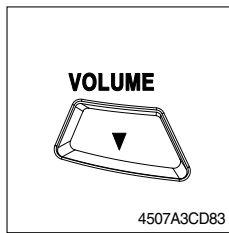

- Short press : Volume down one step
- Long press : Volume down continuous.

(4) Source & mute button



- Short press : Change source(Radio/CD)
- Long press : To mute or cancel mute.

(5) Next button

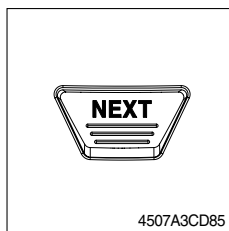

- ① Tuner mode
 - Short press : Preset up
 - Long press : Band up
- ② Cassette mode
 - Short press : Reverse(before the end of the tape)
 - Long press : No function
- ③ CD mode
 - Short press : Track 1
 - Long press : Scan track

(6) Search button(up)

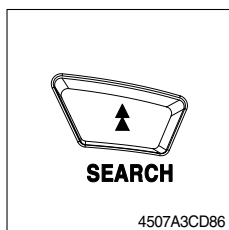

- ① Tuner mode
 - Short press : Search up one step
 - Long press : Search up continuous
- ② Cassette & CD mode
 - Short press : Next track
 - Long press : Fast forward

(7) Search button(down)

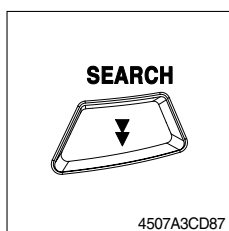

- ① Tuner mode
 - Short press : Search down one step
 - Long press : Search down continuous
- ② Cassette & CD mode
 - Short press : Previous track
 - Long press : Fast rewind