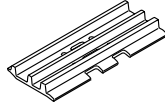
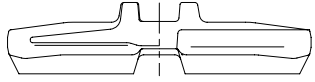

## 7. UNDERCARRIAGE

### 1) TRACKS

X-leg type center frame is integrally welded with reinforced box-section track frames. The design includes dry tracks, lubricated rollers, idlers, sprockets, hydraulic track adjusters with shock absorbing springs and assembled track-type tractor shoes with triple grousers.

### 2) TYPES OF SHOES

Model	Shapes		Steel triple grouser	Rubber track
				
R55-7	Shoe width	mm(in)	400(16)	400(16)
	Operating weight	kg(lb)	5700(12570)	5700(12570)
	Ground pressure	kgf/cm <sup>2</sup> (psi)	0.33(4.69)	0.33(4.69)
	Overall width	mm(ft-in)	1900( 6' 3")	1900( 6' 3")

### 3) NUMBER OF ROLLERS AND SHOES ON EACH SIDE

Item	Quantity
Carrier rollers	1EA
Track rollers	5EA
Track shoes	40EA