

TRANSPORTATION

1. PREPARATION FOR TRANSPORTATION

- 1) When transporting the machine, observe the various road rules, road transportation vehicle laws and vehicle limit ordinances, etc.
- 2) Select proper trailer after confirming the weight and dimension from the chapter 2, specification.
- 3) Check the whole route such as the road width, the height of bridge and limit of weight and etc., which will be passed.
- 4) Get the permission from the related authority if necessary.
- 5) Prepare suitable capacity of trailer to support the machine.

- 6) Prepare gangplank for safe loading referring to the below table and illustration.

A	B
1.0	3.65 ~ 3.85
1.1	4.00 ~ 4.25
1.2	4.35 ~ 4.60
1.3	4.75 ~ 5.00
1.4	5.10 ~ 5.40
1.5	5.50 ~ 5.75

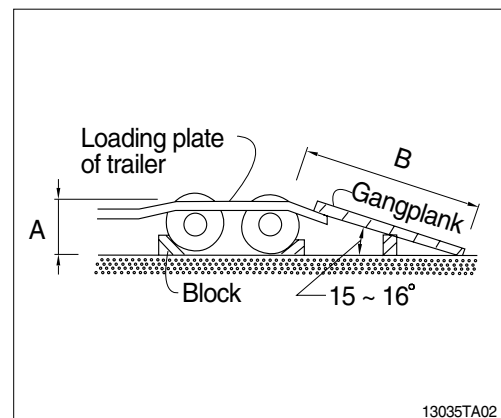
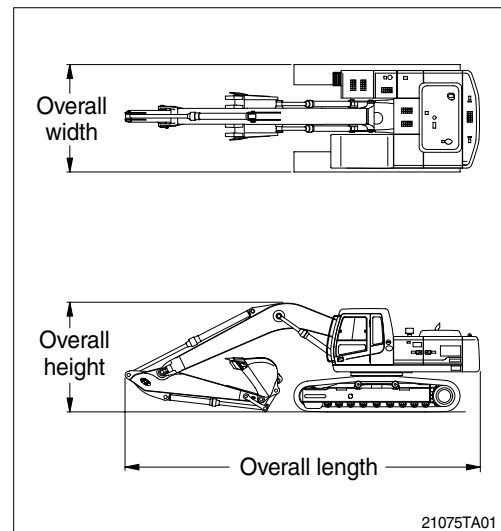

2. DIMENSION AND WEIGHT

1) BASE MACHINE

Mark	Description	Unit	Specification
L	Length	mm(ft-in)	6190(20' 4")
H	Height	mm(ft-in)	3390(11' 1")
W	Width	mm(ft-in)	2990(9'10")
Wt	Weight	kg(lb)	29540(65120)

- ※ With 600mm(24") triple grouser shoes.
- ※ Remove cakewalk for transport.

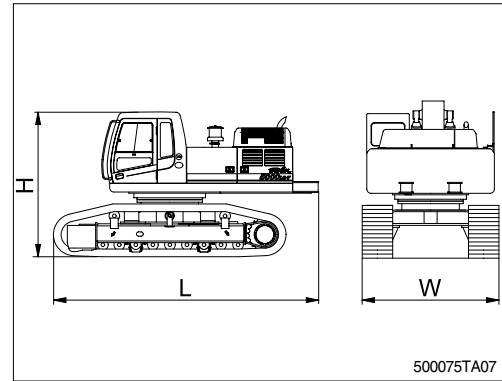

2) BOOM ASSEMBLY

Mark	Description	Unit	Specification
L	Length	mm(ft-in)	7290(23'11")
H	Height	mm(ft-in)	1710(5' 7")
W	Width	mm(ft-in)	830(2' 9")
Wt	Weight	kg(lb)	3910(8620)

- ※ 7.06m(23' 2") boom with arm cylinder(Included piping and pins).

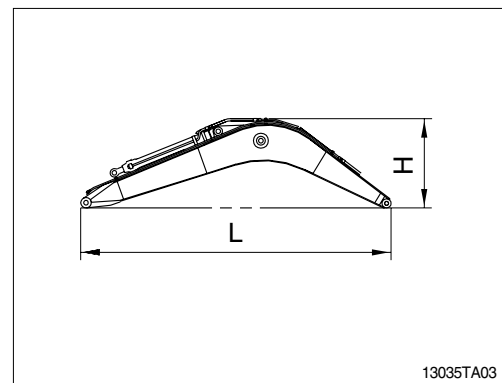

3) ARM ASSEMBLY

Mark	Description	Unit	Specification
L	Length	mm(ft-in)	4600(15' 1")
H	Height	mm(ft-in)	1010(3' 4")
W	Width	mm(ft-in)	620(2' 0")
Wt	Weight	kg(lb)	2100(4630)

- ※ 3.38m(11' 0") arm with bucket cylinder(Included linkage and pins).

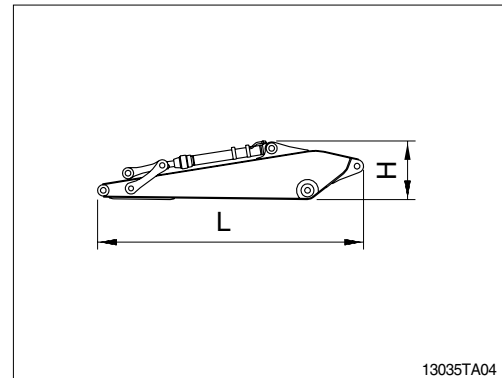

4) BUCKET ASSEMBLY

Mark	Description	Unit	Specification
L	Length	mm(ft-in)	2090(6'10")
H	Height	mm(ft-in)	1240(4' 1")
W	Width	mm(ft-in)	1760(5' 6")
Wt	Weight	kg(lb)	1620(3570)

- ※ 2.15m³(2.81yd³) SAE heaped bucket(Included tooth and side cutters).

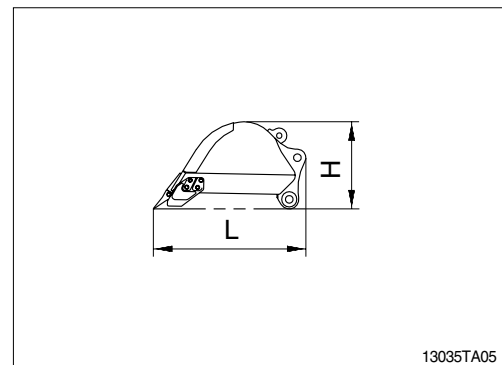

5) BOOM CYLINDER

Mark	Description	Unit	Specification
L	Length	mm(ft-in)	2445(8' 0")
H	Height	mm(ft-in)	326(1' 1")
W	Width	mm(ft-in)	436(1' 5")
Wt	Weight(2EA)	kg(lb)	370(820)

※ Included piping.

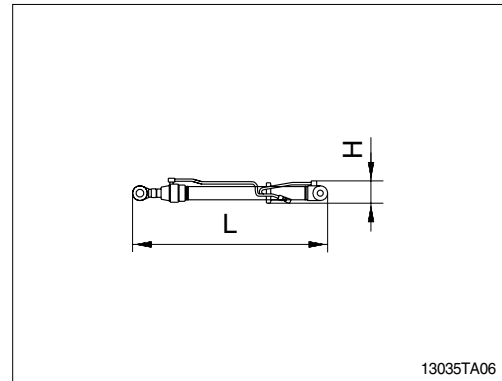

6) CAB ASSEMBLY

Mark	Description	Unit	Specification
L	Length	mm(ft-in)	1962(6' 4")
H	Height	mm(ft-in)	1676(5' 5")
W	Width	mm(ft-in)	1288(4' 3")
Wt	Weight	kg(lb)	310(680)

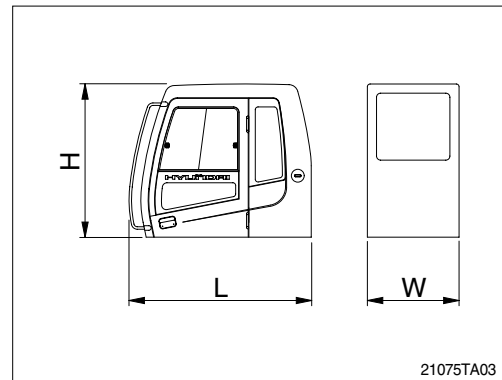

7) COUNTERWEIGHT

Mark	Description	Unit	Specification
L	Length	mm(ft-in)	2980(9' 9")
H	Height	mm(ft-in)	1050(3' 5")
W	Width	mm(ft-in)	768(2' 6")
Wt	Weight	kg(lb)	10200(22490)

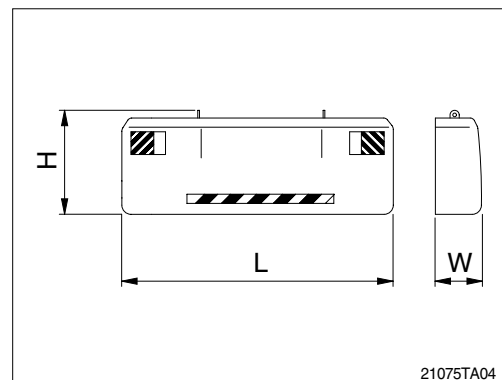

3. DISASSEMBLING FOR TRANSPORTATION

1) DISCONNECTING HYDRAULIC HOSES AND LINES

- (1) Position the machine on flat, firm and level ground.
- (2) Retract the bucket cylinder and arm cylinder completely.
- (3) Lower the boom to the ground as shown.
- (4) Stop the engine.
- (5) Move the safety lever down to lock the system securely.
※ Refer to the page 3-14 for details.
- (6) Turn the engine start switch to ON position.
Do not start the engine.
- (7) Pull up the safety lever, Move the left and right operating levers, respectively to the full extension in all directions to remove internal pressure from the hydraulic circuits.
- (8) Turn the star switch to OFF position.
- (9) Release internal pressure in the hydraulic tank through the air breather of the hydraulic tank.
- (10) Disconnect hoses and lines.
※ **Treat oil in an environmentally safe way.**
- (11) Dismantle the components (boom, arm, counter-weight etc.)

▲ Immediately after operating the machine, the hot hydraulic oil can cause severe burns to unprotected skin.

▲ These may be residual hydraulic pressure can remain in the hydraulic system. Serious injury may result if this residual pressure is not released before any service is done on the hydraulic system.

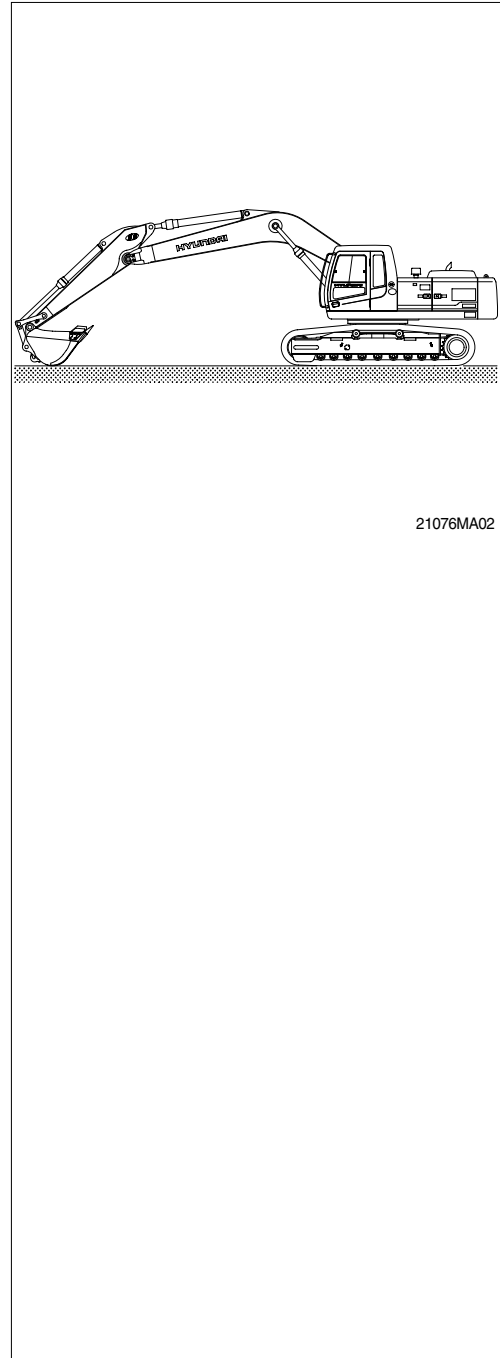

2) DISASSEMBLING ATTACHMENT

※ Follow the disconnecting hydraulic hoses and lines procedure before disassemble the components.

(1) Bucket and arm with bucket cylinder

Use cable sheaths to protect the lifting cable from being damaged by the edges of the arm.
Protect piston rod and the cylinder tube.

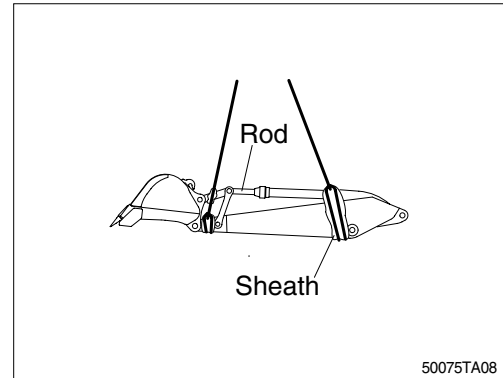

(2) Boom with arm cylinder

Use cable sheaths to protect the lifting cable from being damaged by the edges of the boom.
Secure piston rod of the arm cylinder to the cylinder tube.

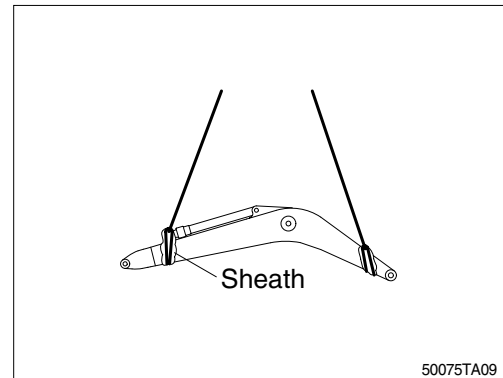

3) COUNTERWEIGHT REMOVAL AND INSTALLATION

(1) Counterweight removal

- ① Position the machine on flat, firm and level ground, free from any obstruction or interference.
- ② Keep the service position.
- ③ Push down the safety locking lever securely. Move the safety lever down to lock the system securely.
※ Refer to the page 3-14 for details.
- ④ As shown in the illustration, connect the lifting cables or slings with sufficient strength for the counterweight at the lifting eye correctly.
- ⑤ Disassemble four bolts.
- ⑥ Lift the counterweight enough.
- ⑦ Place the counterweight onto suitable support.

(2) Counterweight installation

- ① Carry out installation in the reverse order to removal.
· Tightening torque : $390 \pm 40 \text{kgf} \cdot \text{m}$ ($280 \pm 290 \text{lb} \cdot \text{ft}$)
- ▲ Move the safety locking lever down to lock the system securely, See safety locking system on page 3-14. And attach a warning tag(Do not start the engine) to the left operating lever.**
- ▲ Personal injury or death can occur from a counterweight falling during installation. Do not allow personnel under or around the counterweight during installation.**
- ▲ Use certified cables and shackles of adequate load rating. Improper lifting can allow the load to shift and cause injury or death.**

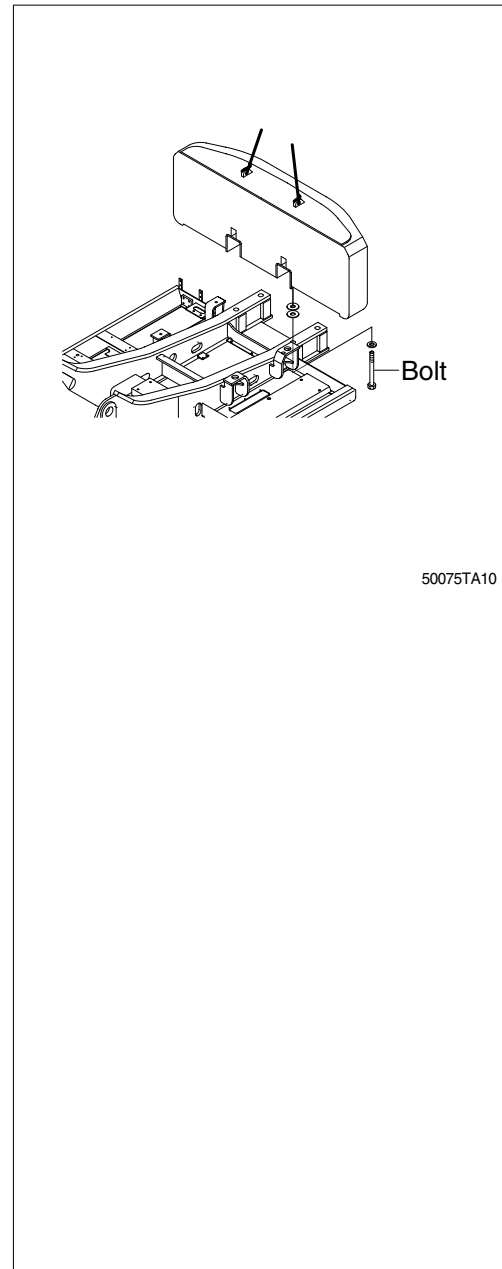

4. LOADING THE MACHINE

- 1) Load and unload the machine on a flat ground.
- 2) Use the gangplank with sufficient length, width, thickness and gradient.
- 3) Place the swing lock lever to the LOCK position before fixing the machine at the bed of trailer and confirm if the machine parallels the bed of trailer. Keep the travel motor in the rear when loading and in the front when unloading.

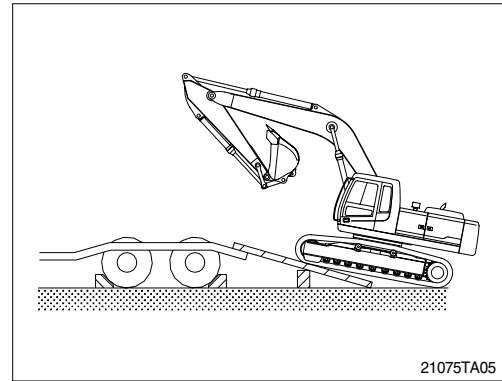

- 4) Do the following after loading the machine to the trailer.
 - (1) Stop loading when the machine is located horizontally with the rear wheel of trailer.

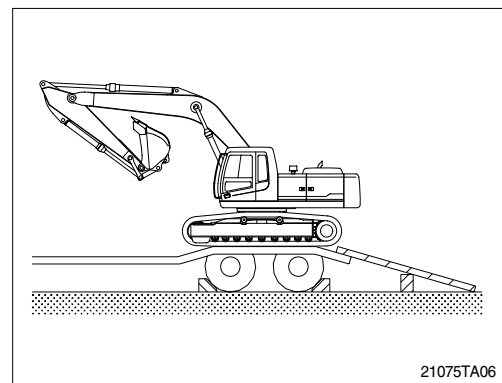

- (2) Place the swing lock lever to the LOCK position after the swing the machine 180 degree.

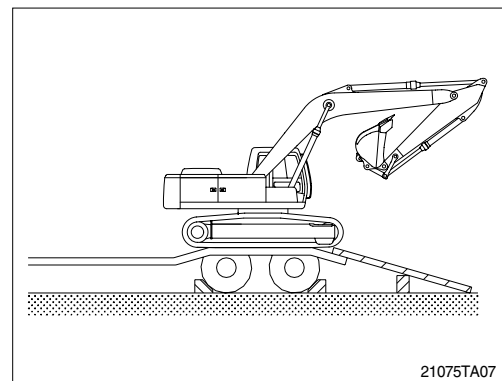

(3) Lower the working equipment gently after the location is determined.

※ Place rectangular timber under the bucket cylinder to prevent the damage of it during transportation.

▲ Be sure to keep the travel speed switch on the LOW(Turtle mark) while loading and unloading the machine.

▲ Avoid using the working equipment for loading and unloading since it will be very dangerous.

▲ Do not operate any other device when loading.

▲ Be careful on the boundary place of loading plate or trailer as the balance of machine will abruptly be changed on the point.

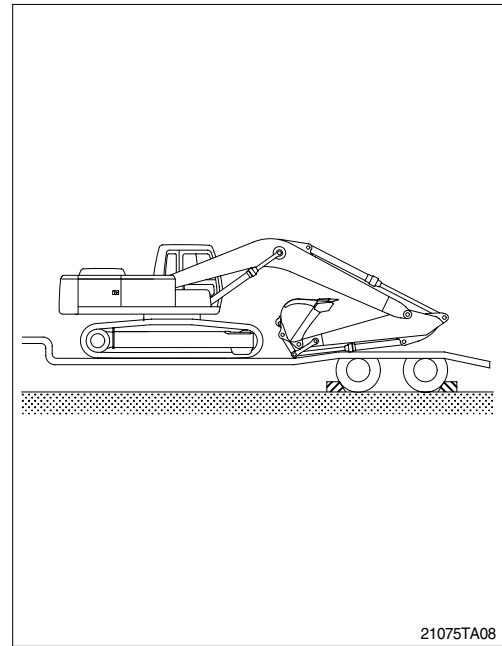

5. FIXING THE MACHINE

- 1) Lower down the working device on the loading plate of trailer.
- 2) Keep the safety lever on the LOCK position.
- 3) Turn OFF all the switches and remove the key.

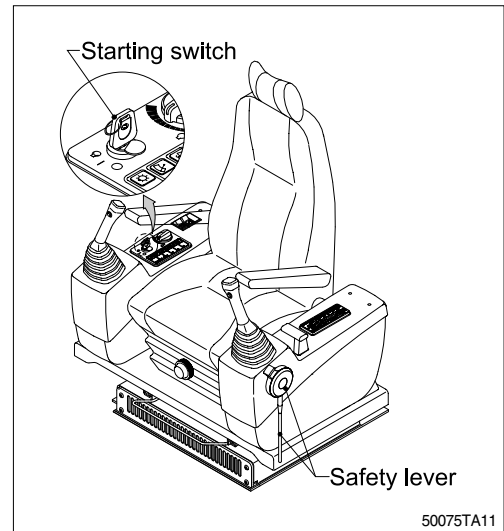

- 4) Secure all locks.

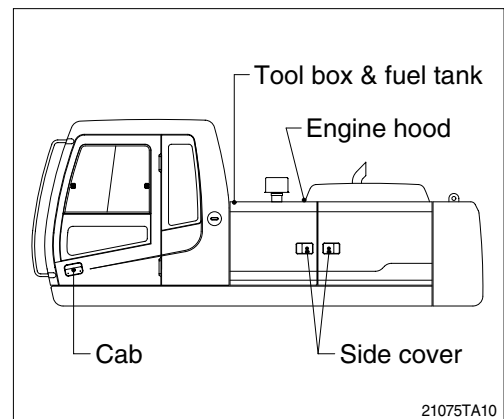

- 5) Place timber underneath of the track and fix firmly with wire rope to prevent the machine from moving forward, backward, right or left.

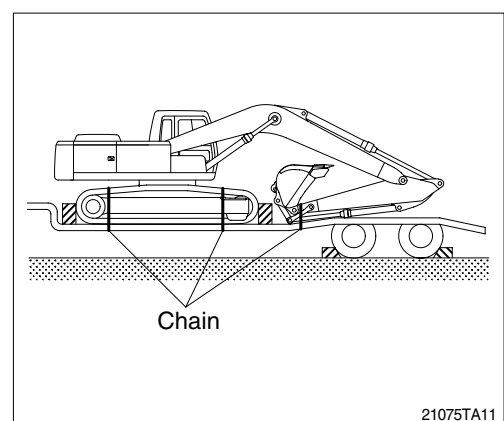

6. LOADING AND UNLOADING BY CRANE

- 1) Check the weight, length, width and height of the machine referring to the chapter 2, specification when you are going to hoist the machine.
 - 2) Use long wire rope and stay to keep the distance with the machine as it should avoid touching with the machine.
 - 3) Put a rubber plate contact with wire rope and machine to prevent damage.
 - 4) Place crane on the proper place.
 - 5) Install the wire rope and stay like the illustration.
- ▲ Make sure wire rope is proper size.
 - ▲ Place the swing lock lever and safety lever to LOCK position to prevent the machine moving when hoisting the machine.
 - ▲ The wrong hoisting method or installation of wire rope can cause damage to the machine.
 - ▲ Do not load abruptly.
 - ▲ Keep area clear of personnel.

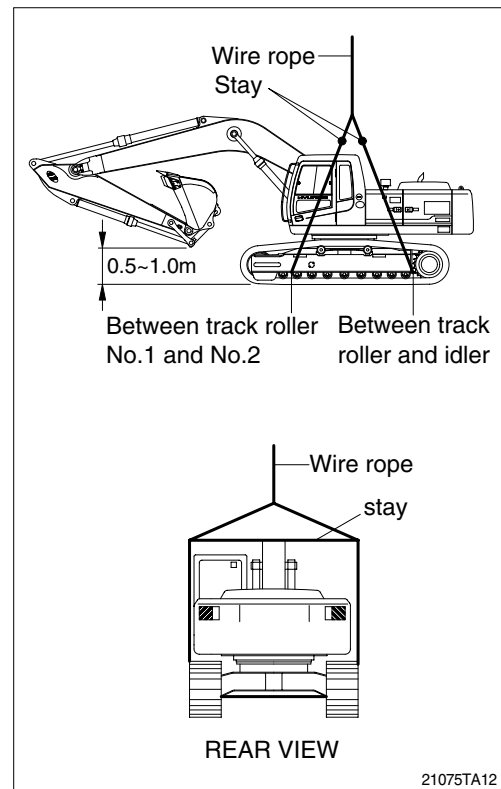

7. ADJUSTABLE TRACK GAUGE

1) LOWER TRACK RETRACTION

▲ Do not retract the track gauge except transporting purpose.

(1) Remove nine bolts(1), and spacers from lower track(2) to the retracted.

※ Do not loosen two bolts(3) on guide(4).

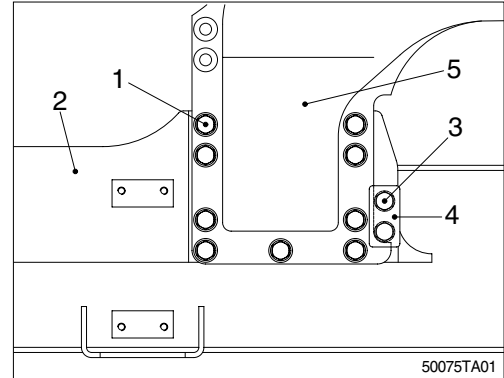

(2) Turn superstructure so that it is perpendicular to lower track to be retracted. Raise lower track to approximately 15degree from ground using a jack. Lower track should slide by its own weight and hit against the stop.

※ If lower track does not slide in this condition, allow lower track that is not contraction ground to move back and forth slowly.

**▲ The arm must be set at 90~110degree.
Never set it at an angle less than 90degree.**

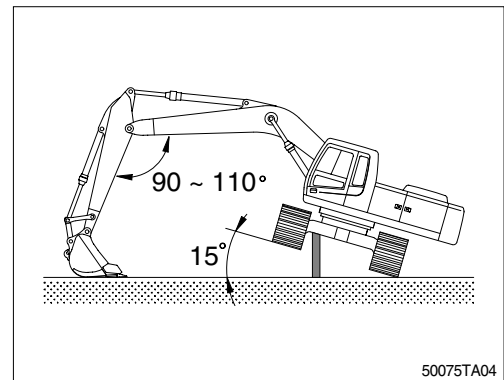

(3) After lower track(2) has slid into place, lower superstructure to ground.

Install six spacers and bolts(1).

※ Tighten bolts to $220 \pm 20 \text{ kgf} \cdot \text{m}$ ($1590 \pm 145 \text{ lbf} \cdot \text{ft}$)

※ Repeat procedure at opposite side center frame support.

(4) After the bolts for one side frame are fastened, repeat steps 1 thru 3 for opposite side frame.

(5) Store remaining bolts, spacers with machine.

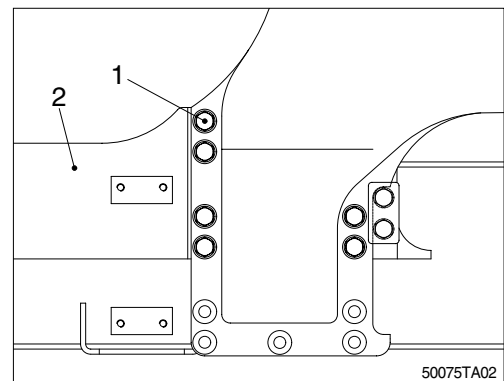

1) FRAME EXTENSION

(1) Remove six bolts(1), and spacers from lower track(2) to be extended.

※ Do not loosen two bolts(3) on guide(4).

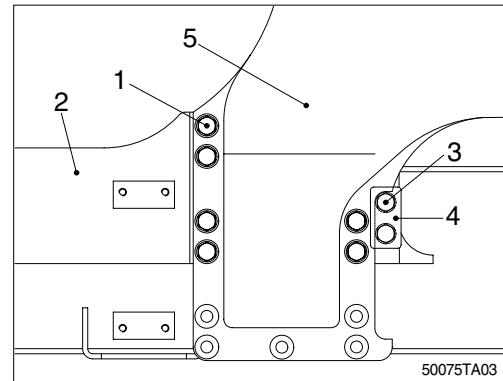

(2) Turn superstructure so that it is perpendicular to lower track to be extended.

※ Do not attach cable on side frame step.

(3) Attach one end of cable on arm and the other end on lower track.

Connect it with an appropriate holding device on both ends.

(4) Raise lower track slightly with jack and block. Extend arm gradually to side frame out until it hits stop.

(5) After lower track has slid into place, lower superstructure to ground.

Remove cable.

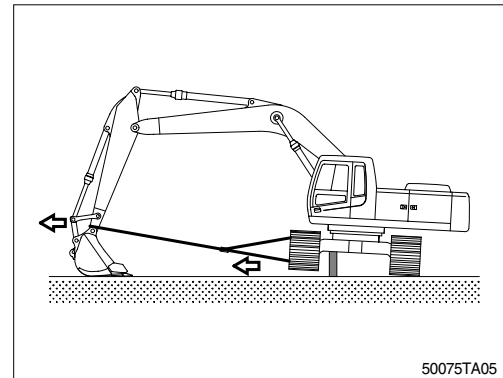

(6) Install nine spacers and bolts(2).

※ Tighten bolts to $220 \pm 20 \text{kgf} \cdot \text{m}$ ($1590 \pm 145 \text{lb} \cdot \text{ft}$)

※ Repeat procedure at opposite track frame support.

(7) After the bolts for one side frame are fastened repeat steps 1 thru 6 for other side frame.

