

## 7. ADJUSTABLE TRACK GAUGE (R520LC-9)

### 1) LOWER TRACK RETRACTION

▲ Do not retract the track gauge except transporting purpose.

(1) Remove nine bolts (1), and spacers from lower track (2) to the retracted.

※ Do not loosen two bolts (3) on guide (4).

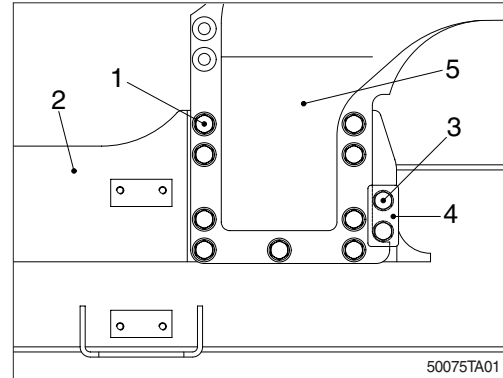

(2) Turn superstructure so that it is perpendicular to lower track to be retracted. Raise lower track to approximately 15degree from ground using a jack. Lower track should slide by its own weight and hit against the stop.

※ If lower track does not slide in this condition, allow lower track that is not contraction ground to move back and forth slowly.

▲ The arm must be set at 90~110°.  
Never set it at an angle less than 90°.

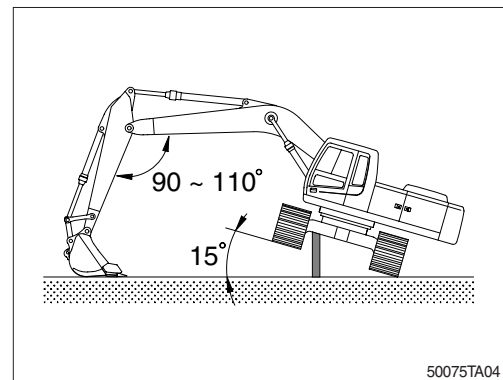

(3) After lower track (2) has slid into place, lower superstructure to ground.

Install six spacers and bolts (1).

※ Tighten bolts to  $220 \pm 20 \text{ kgf} \cdot \text{m}$  ( $1590 \pm 145 \text{ lbf} \cdot \text{ft}$ )

※ Repeat procedure at opposite side center frame support.

(4) After the bolts for one side frame are fastened, repeat steps 1 thru 3 for opposite side frame.

(5) Store remaining bolts, spacers with machine.

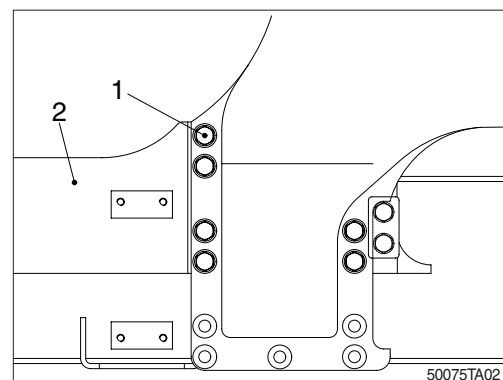

## 2) FRAME EXTENSION

(1) Remove six bolts (1), and spacers from lower track (2) to be extended.

※ **Do not loosen two bolts (3) on guide (4).**

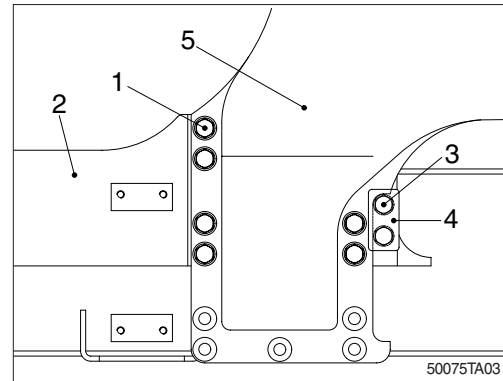

(2) Turn superstructure so that it is perpendicular to lower track to be extended.

※ **Do not attach cable on side frame step.**

(3) Attach one end of cable on arm and the other end on lower track.

Connect it with an appropriate holding device on both ends.

(4) Raise lower track slightly with jack and block. Extend arm gradually to side frame out until it hits stop.

(5) After lower track has slid into place, lower superstructure to ground. Remove cable.

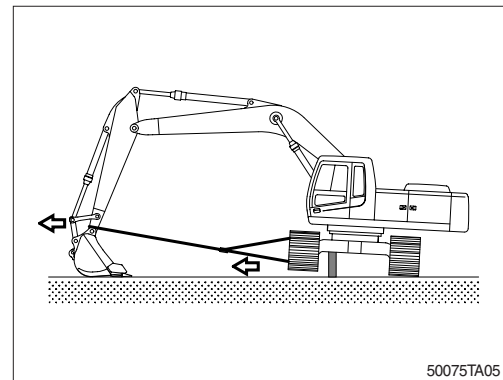

(6) Install nine spacers and bolts (2).

※ **Tighten bolts to  $220 \pm 20$  kgf·m ( $1590 \pm 145$  lbf·ft)**

※ **Repeat procedure at opposite track frame support.**

(7) After the bolts for one side frame are fastened repeat steps 1 thru 6 for other side frame.

