

## 5. MAINTENANCE CHART

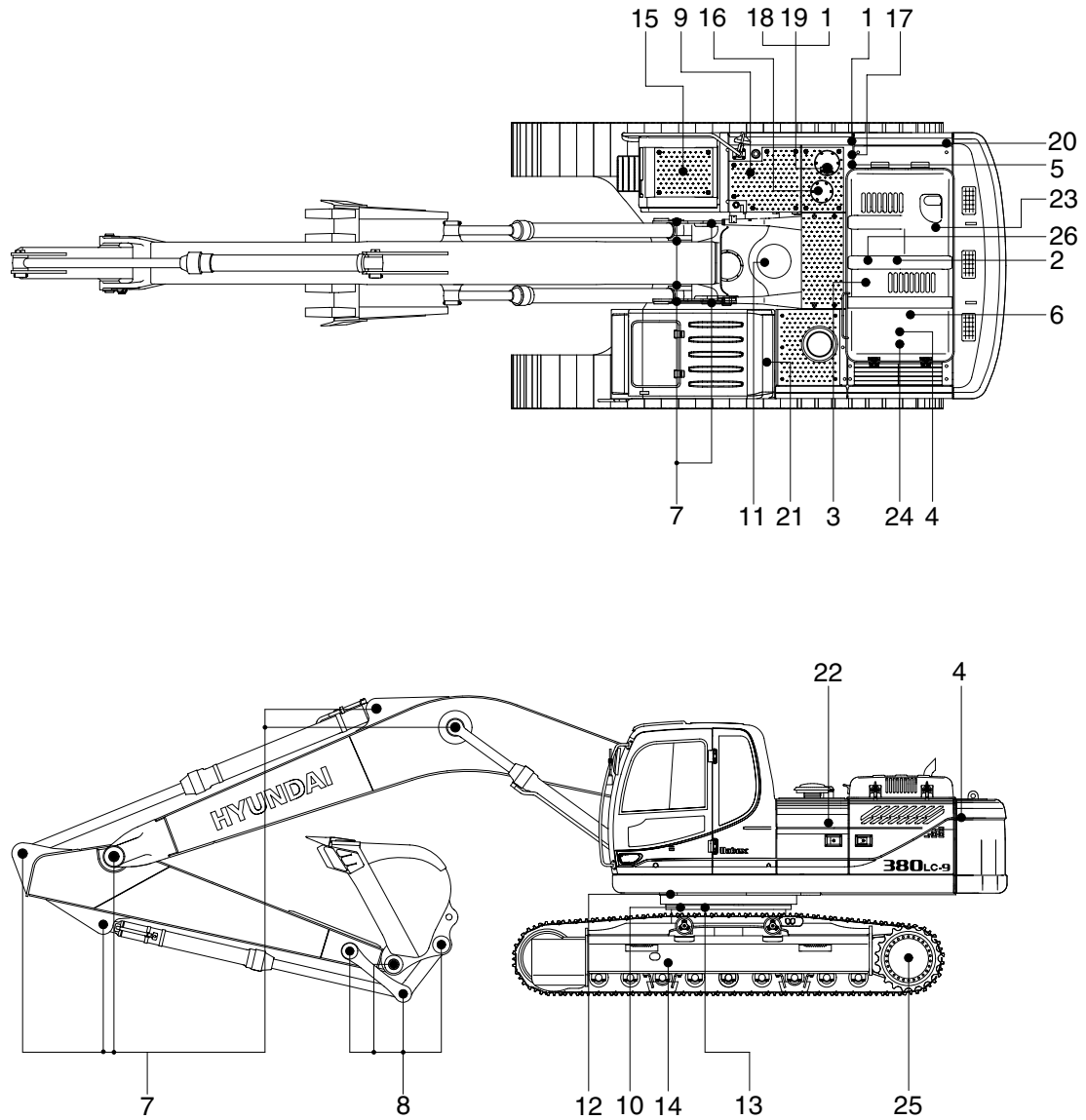

38096MA01

### Caution

1. Service intervals are based on the hour meter reading.
2. The number of each item shows the lubrication point on the machine.
3. Stop engine while filling oil, and use no open flames.

Service interval	No.	Description	Service action	Oil symbol	Capacity / (U.S.gal)	Service points No.
10 Hours or daily	1	Hydraulic oil level	Check, Add	HO	210 (55.5)	1
	2	Engine oil level	Check, Add	EO	33.5 (8.8)	1
	4	Radiator coolant	Check, Add	C	35 (9.2)	1
	5	Prefilter (water, element)	Check, Clean	-	-	1
	6	Fan belt tension and damage	Check, Adjust	-	-	1
	9	Fuel tank	Check, Refill	DF	550 (145.3)	1
50 Hours or weekly	8	Bucket linkage pin	Check, Add	PGL	-	6
	9	Fuel tank (water, sediment)	Check, Clean	-	-	1
	10	Swing bearing grease	Check, Add	PGL	-	3
	11	Swing reduction gear case	Check, Add	GO	8.0 (2.1)	1
250 Hours	14	Track tension	Check, Adjust	PGL	-	2
	7	Attachment pins & bushing	Check, Add	PGL	-	11
	15	Battery (voltage)	Check, Clean	-	-	1
	18	Air breather element	Replace	-	-	1
500 Hours	21	Aircon and heater fresh air filter	Check, Clean	-	-	1
	2	Engine oil	Change	EO	33.5 (8.8)	1
	3	Engine oil filter	Replace	-	-	1
	5	Prefilter	Replace	-	-	1
	22	Air cleaner element (primary)	Check, Clean	-	-	1
	23	Fuel filter element	Replace	-	-	1
	24	Radiator, oil cooler, charge air cooler	Check, Clean	-	-	3
1000 Hours	26	Water filter(corrosion resister)	Replace	-	-	1
	6	Fan belt tensioner	Check, Replace	-	-	1
	11	Swing reduction gear case	Change	GO	8.0 (2.1)	1
	13	Swing gear and pinion grease	Change	PGL	11.5 kg (25.4 lb)	1
	16	Hydraulic oil return filter	Replace	-	-	2
	17	Drain filter cartridge	Replace	-	-	1
	20	Pilot line filter element	Replace	-	-	1
2000 Hours	25	Travel reduction gear case	Change	GO	7.0 (1.8)	2
	1	Hydraulic oil * <sup>1</sup>	Change	HO	210 (55.5)	1
	4	Radiator coolant	Change	C	35 (9.2)	1
5000 Hours	19	Hydraulic oil suction strainer	Check, Clean	-	-	1
	1	Hydraulic oil * <sup>2</sup>	Change	HO	210 (55.5)	1
As required	21	Aircon & heater fresh filter	Replace	-	-	1
	21	Aircon & heater recirculation filter	Clean, Replace	-	-	1
	22	Air cleaner element (primary, safety)	Replace	-	-	2

\*<sup>1</sup> Conventional hydraulic oil      \*<sup>2</sup> Hyundai genuine long life hydraulic oil

※ Oil symbol

Please refer to the recommended lubricants for specification.

DF : Diesel fuel      GO : Gear oil      HO : Hydraulic oil  
C : Coolant      PGL : Grease      EO : Engine oil