

2. DIMENSION AND WEIGHT

(1) Base machine

Mark	Description	Unit	Specification
L	Length	mm (ft-in)	5985 (19' 8")
H	Height	mm (ft-in)	3175 (10' 5")
W	Width	mm (ft-in)	3440 (11' 3")
Wt	Weight	kg (lb)	29350 (64710)

※ With 600 mm (24") triple grouser shoes and 6500 kg (14300 lb) counterweight.

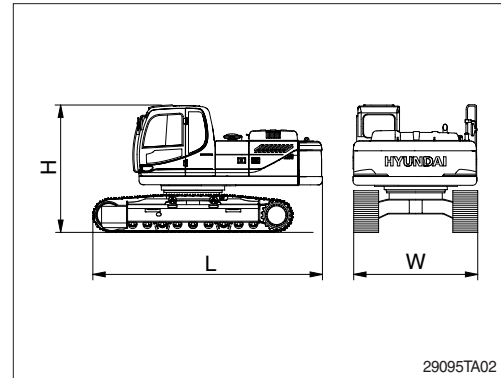

29095TA02

(2) Boom assembly

Mark	Description	Unit	Specification
L	Length	mm (ft-in)	6730 (22' 1")
H	Height	mm (ft-in)	1760 (5' 9")
W	Width	mm (ft-in)	830 (2' 9")
Wt	Weight	kg (lb)	3780 (8335)

※ 6.5 m (21' 4") boom with arm cylinder (included piping and pins).

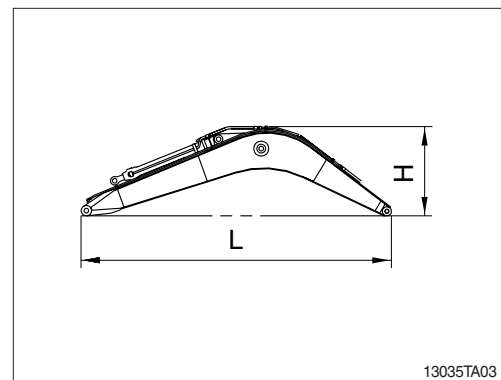

13035TA03

(3) Arm assembly

Mark	Description	Unit	Specification
L	Length	mm (ft-in)	4390 (14' 5")
H	Height	mm (ft-in)	1070 (3' 6")
W	Width	mm (ft-in)	430 (1' 5")
Wt	Weight	kg (lb)	2050 (4520)

※ 3.2 m (10' 6") arm with bucket cylinder (included linkage and pins).

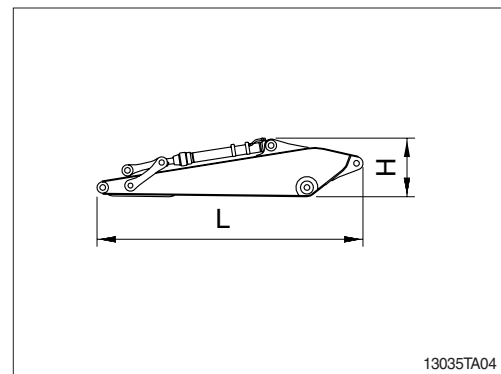

13035TA04

(4) Bucket assembly

Mark	Description	Unit	Specification
L	Length	mm (ft-in)	1900 (6' 3")
H	Height	mm (ft-in)	1130 (3' 8")
W	Width	mm (ft-in)	1585 (5' 2")
Wt	Weight	kg (lb)	1280 (2820)

※ 1.62 m³ (2.12 yd³) SAE heaped bucket (included tooth and side cutters).

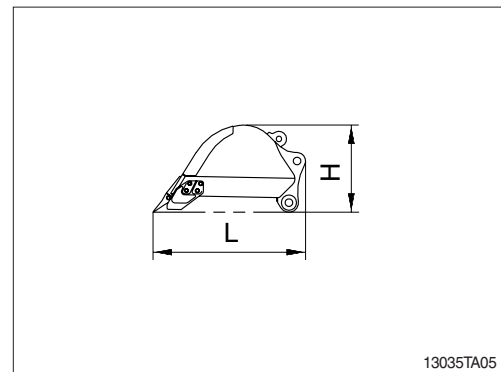

13035TA05

(5) Boom cylinder

Mark	Description	Unit	Specification
L	Length	mm (ft-in)	2300 (7' 7")
H	Height	mm (ft-in)	350 (1' 2")
W	Width	mm (ft-in)	425 (1' 5")
Wt	Weight	kg (lb)	740 (1630)

※ Included piping.

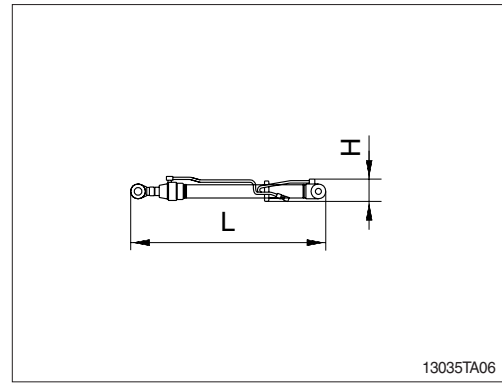

(6) Cab assembly

Mark	Description	Unit	Specification
L	Length	mm (ft-in)	1962 (6' 4")
H	Height	mm (ft-in)	1686 (5' 6")
W	Width	mm (ft-in)	1000 (3' 3")
Wt	Weight	kg (lb)	490 (1080)

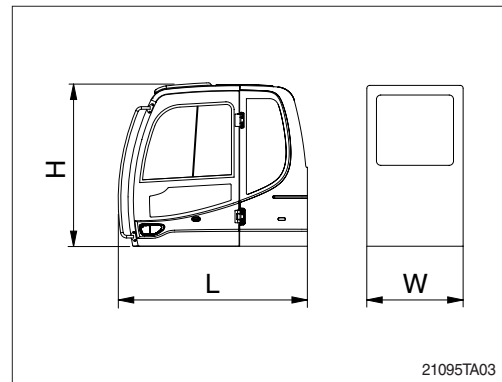

(7) Counterweight

Mark	Description	Unit	Specification
L	Length	mm (ft-in)	2980 (9' 9")
H	Height	mm (ft-in)	1165 (3' 10")
W	Width	mm (ft-in)	630 (2' 1")
Wt	Weight	kg (lb)	6500 (14330)

