

1. INSTRUCTION

1) INTERVAL OF MAINTENANCE

- (1) You may inspect and service the machine by the period as described at page 6-11 based on service meter at cluster support.
- (2) Shorten the interval of inspect and service depending on site condition.(Such as dusty area, quarry, sea shore and etc.)
- (3) Practice the entire related details at the same time when the service interval is doubled.
For example, in case of 100hours, carry out all the maintenance 「 Each 100hours, each 50 hours and daily service 」 at the same time.

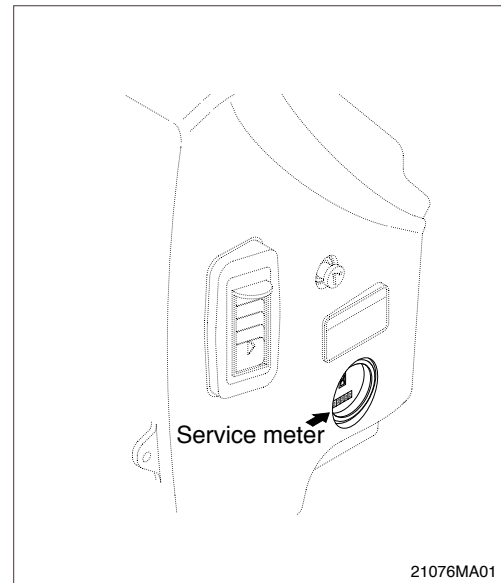

2) PRECAUTION

- (1) Start to maintenance after you have the full knowledge of machine.
- (2) The monitor installed on this machine does not entirely guarantee the condition of the machine.
Daily inspection should be performed according to clause 4, maintenance check list.
- (3) Engine and hydraulic components have been preset in the factory.
Do not allow unauthorized personnel to reset them.
- (4) Ask to your local dealer or Hyundai for the maintenance advice if unknown.
- (5) Drain the used oil and coolant in a container and handle according to the method of handling for industrial waste to meet with regulations of each province or country.

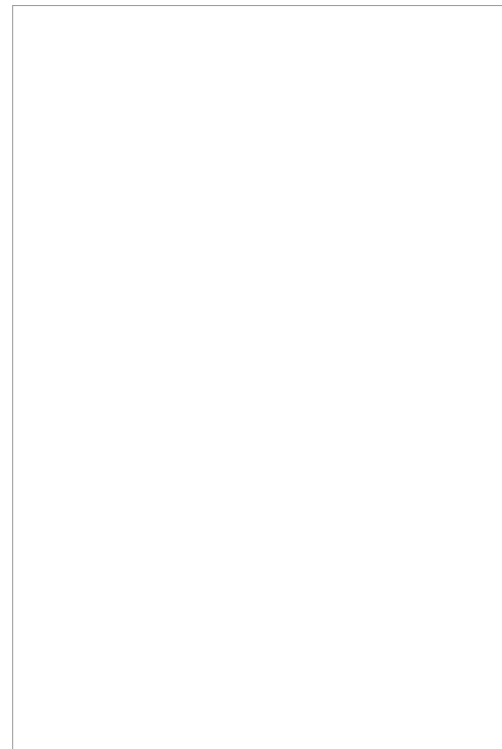

3) PROPER MAINTENANCE

(1) Replace and repair of parts

It is required to replace the wearable and consumable parts such as bucket tooth, side cutter, filter and etc., regularly.

Replace damaged or worn parts at proper time to keep the performance of machine.

- (2) Use genuine parts.
- (3) Use the recommended oil.
- (4) Remove the dust or water around the inlet of oil tank before supplying oil.
- (5) Drain oil when the temperature of oil is warm.
- (6) Do not repair anything while operating the engine.
Stop the engine when you fill the oil.
- (7) Relieve hydraulic system of the pressure before repairing the hydraulic system.
- (8) Confirm if the cluster is in the normal condition after completion of service.
- (9) For more detail information of maintenance, please contact local Hyundai dealer.
Be sure to start the maintenance after fully understand the chapter 1, safety hints.

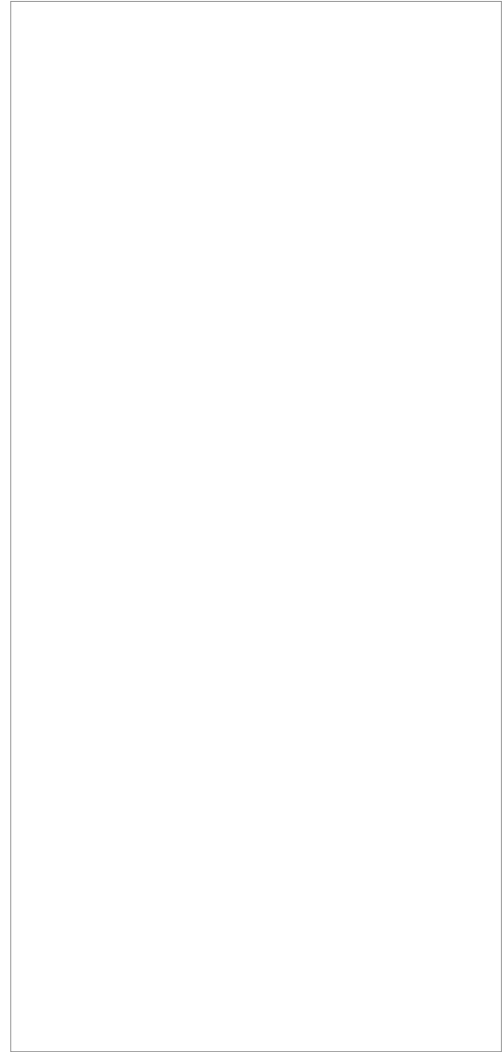

4) RELIEVING THE PRESSURE IN THE HYDRAULIC SYSTEM

Spouting of oil can cause the accident when loosening the cap or hose right after the operating of machine as the machine or oil is on the high pressure on the condition.

Be sure to relieve the pressure in the system before repairing hydraulic system.

- (1) Place machine in parking position, and stop the engine.

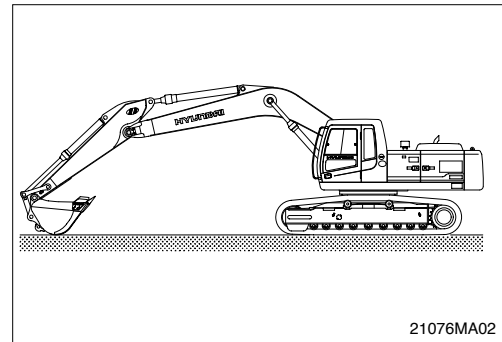

- (2) Set the safety lever completely in the release position, operate the control levers and pedals fully to the front, rear, left and right, to release the pressure in the hydraulic circuit.

This does not completely release the pressure, so when serving hydraulic component, loosen the connections slowly and do not stand in the direction where the oil spurt out.

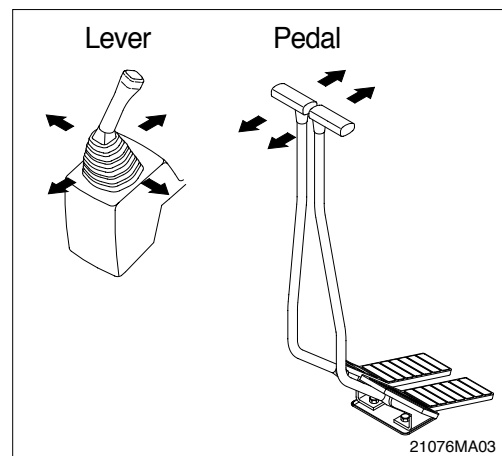

- (3) Relieve the pressure in the tank by loosening the air breather.

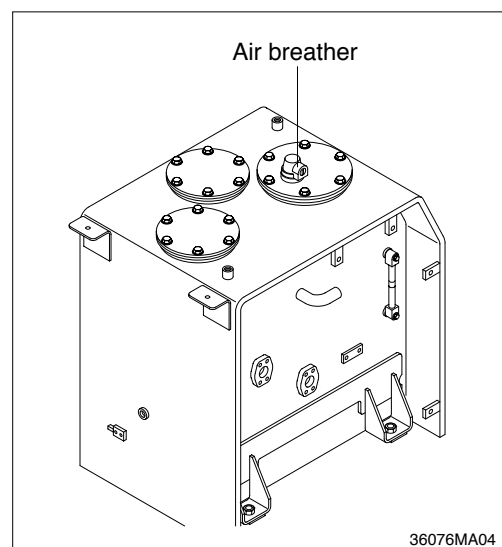

5) PRECAUTION WHEN INSTALLING HYDRAULIC HOSES OR PIPES

- (1) Be particularly careful that the joint of hose, pipe and functioning item are not damaged.
Avoid contamination.
- (2) Assemble after cleaning the hose, pipe and joint of functioning item.
- (3) Use genuine parts.
- (4) Do not assemble the hose in the condition of twisted or sharp radius.
- (5) Keep the specified tighten torque.

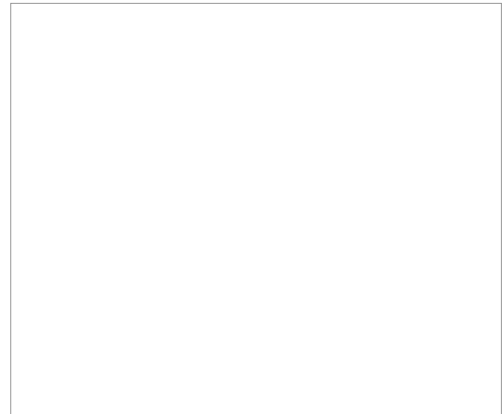

6) PERIODICAL REPLACEMENT OF SAFETY PARTS

(1) It is desirable to do periodic maintenance the machine for using the machine safely for a long time.

However, recommend to replace regularly the parts related safety not only safety but maintain satisfied performance.

(2) These parts can cause the disaster of life and material as the quality changes by passing time and it is worn, diluted, and gets fatigued by using repeatedly.

These are the parts which the operator can not judge the remained lifetime of them by visual inspection.

(3) Repair or replace if an abnormality of these parts is found even before the recommended replacement interval.

Periodical replacement of safety parts		Interval	
Engine	Fuel hose(tank-engine)	Every 2 years	
	Heater hose (heater-engine)		
Hydraulic system	Main circuit	Pump suction hose	Every 2 years
		Pump delivery hose	
		Swing hose	
	Working device	Boom cylinder line hose	Every 2 years
		Arm cylinder line hose	
Bucket cylinder line hose			

1. Replace O-ring and gasket at the same time when replacing the hose.

2. Replace clamp at the same time if the hose clamp is cracked when checking and replacing the hose.

2. TIGHTENING TORQUE

Use following table for unspecified torque.

1) BOLT AND NUT

(1) Coarse thread

Bolt size	8T		10T	
	kgf · m	lbf · ft	kgf · m	lbf · ft
M 6 × 1.0	0.85 ~ 1.25	6.15 ~ 9.04	1.14 ~ 1.74	8.2 ~ 12.6
M 8 × 1.25	2.0 ~ 3.0	14.5 ~ 21.7	2.7 ~ 4.1	19.5 ~ 29.7
M10 × 1.5	4.0 ~ 6.0	28.9 ~ 43.4	5.5 ~ 8.3	39.8 ~ 60.0
M12 × 1.75	7.4 ~ 11.2	53.5 ~ 81.0	9.8 ~ 15.8	70.9 ~ 114
M14 × 2.0	12.2 ~ 16.6	88.2 ~ 120	16.7 ~ 22.5	121 ~ 163
M16 × 2.0	18.6 ~ 25.2	135 ~ 182	25.2 ~ 34.2	182 ~ 247
M18 × 2.0	25.8 ~ 35.0	187 ~ 253	35.1 ~ 47.5	254 ~ 344
M20 × 2.5	36.2 ~ 49.0	262 ~ 354	49.2 ~ 66.6	356 ~ 482
M22 × 2.5	48.3 ~ 63.3	349 ~ 458	65.8 ~ 98.0	476 ~ 709
M24 × 3.0	62.5 ~ 84.5	452 ~ 611	85.0 ~ 115	615 ~ 832
M30 × 3.0	124 ~ 168	898 ~ 1214	169 ~ 229	1223 ~ 1656
M36 × 4.0	174 ~ 236	1261 ~ 1704	250 ~ 310	1808 ~ 2242

(2) Fine thread

Bolt size	8T		10T	
	kgf · m	lbf · ft	kgf · m	lbf · ft
M 8 × 1.0	2.2 ~ 3.4	15.9 ~ 24.6	3.0 ~ 4.4	21.7 ~ 31.8
M10 × 1.2	4.5 ~ 6.7	32.5 ~ 48.5	5.9 ~ 8.9	42.7 ~ 64.4
M12 × 1.25	7.8 ~ 11.6	56.4 ~ 83.9	10.6 ~ 16.0	76.7 ~ 116
M14 × 1.5	13.3 ~ 18.1	96.2 ~ 131	17.9 ~ 24.1	130 ~ 174
M16 × 1.5	19.9 ~ 26.9	144 ~ 195	26.6 ~ 36.0	192 ~ 260
M18 × 1.5	28.6 ~ 43.6	207 ~ 315	38.4 ~ 52.0	278 ~ 376
M20 × 1.5	40.0 ~ 54.0	289 ~ 391	53.4 ~ 72.2	386 ~ 522
M22 × 1.5	52.7 ~ 71.3	381 ~ 516	70.7 ~ 95.7	511 ~ 692
M24 × 2.0	67.9 ~ 91.9	491 ~ 665	90.9 ~ 123	658 ~ 890
M30 × 2.0	137 ~ 185	990 ~ 1339	182 ~ 248	1314 ~ 1796
M36 × 3.0	192 ~ 260	1390 ~ 1880	262 ~ 354	1894 ~ 2562

2) PIPE AND HOSE

Thread size	Width across flat(mm)	kgf · m	lbf · ft
1/4"	19	3	21.7
3/8"	22	4	28.9
1/2"	27	5	36.2
3/4"	36	12	86.8
1"	41	14	101

3) FITTING

Thread size	Width across flat(mm)	kgf · m	lbf · ft
1/4"	19	4	28.9
3/8"	22	5	36.2
1/2"	27	6	43.4
3/4"	36	13	94.0
1"	41	15	109

4) TIGHTENING TORQUE OF MAJOR COMPONENT

No.	Descriptions	Bolt size	Torque		
			kgf · m	lbf · ft	
1	Engine	Engine mounting bolt, nut	M24 × 3.0	90 ± 7.0	651 ± 51
2		Radiator mounting bolt	M16 × 2.0	22 ± 1.0	159 ± 7.2
3		Coupling mounting socket bolt	M20 × 2.5	46.5 ± 2.5	336 ± 18.1
4		Main pump housing mounting bolt	M10 × 1.5	2.8 ± 0.3	20.3 ± 2.2
5	Hydraulic system	Main pump mounting socket bolt	M20 × 2.5	42 ± 4.5	304 ± 32.5
6		Main control valve mounting bolt	M16 × 2.0	19.5 ± 1.3	141 ± 9.4
7		Fuel tank mounting bolt	M20 × 2.5	46 ± 5.0	333 ± 36
8		Hydraulic oil tank mounting bolt	M20 × 2.5	46 ± 5.0	333 ± 36
9		Turning joint mounting bolt, nut	M12 × 1.75	12.3 ± 1.3	88.9 ± 9.4
10	Power train system	Swing motor mounting bolt	M24 × 3.0	100 ± 15	723 ± 108
11		Swing bearing upper part mounting bolt	M24 × 3.0	97.8 ± 10	707 ± 72.3
12		Swing bearing lower part mounting bolt	M24 × 3.0	97.8 ± 10	707 ± 72.3
13		Travel motor mounting bolt	M20 × 2.5	43.8 ± 4.0	317 ± 29
14		Sprocket mounting bolt	M20 × 2.5	51 ± 4.0	369 ± 28.9
15	Under carriage	Carrier roller mounting bolt, nut	M16 × 2.0	29.7 ± 4.0	215 ± 28.9
16		Track roller mounting bolt	M22 × 2.5	77.4 ± 11	560 ± 79.6
17		Track tension cylinder mounting bolt	M16 × 2.0	29.6 ± 3.2	214 ± 23.1
18		Track shoe mounting bolt, nut	3/4-16UNF	105 ± 5.0	755 ± 36.2
19		Track guard mounting bolt	M22 × 2.5	77.4 ± 11	560 ± 79.6
20	Others	Counter weight mounting bolt	M36 × 3.0	308 ± 46	2228 ± 333
21		Cab mounting bolt	M12 × 1.75	12.8 ± 3.0	92.6 ± 21.7
22		Operator's seat mounting bolt	M 8 × 1.25	4.05 ± 0.8	29.3 ± 5.8

※ For tightening torque of engine and hydraulic components, see engine maintenance guide and service manual.

3. FUEL, COOLANT AND LUBRICANTS

1) NEW MACHINE

New machine used and filled with following lubricants.

Description	Specification
Engine oil	SAE 15W-40(API CF-4)
Hydraulic oil	ISO VG 46(SAE 10W)
Swing and travel reduction gear	SAE 85W-140(API GL-5)
Grease	Lithium base grease NLGI No. 2
Fuel	ASTM D975-No. 2
Coolant	Mixture of 50% ethylene glycol base antifreeze and 50% water.

SAE : Society of Automotive Engineers

API : American Petroleum Institute

ISO : International Organization for Standardization

NLGI : National Lubricating Grease Institute

ASTM : American Society of Testing and Material

2) RECOMMENDED OILS

Use only oils listed below or equivalent.

Do not mix different brand oil.

Service point	Kind of fluid	Capacity (U.S. gal)	Ambient temperature °C (°F)						
			-20 (-4)	-10 (14)	0 (32)	10 (50)	20 (68)	30 (86)	40 (104)
Engine oil pan	Engine oil	26.5(7.0)	SAE 30						
			SAE 10W						
			SAE 10W-30						
			SAE 15W-40						
Swing drive	Gear oil	6.0(1.6)	SAE 85W-140						
Final drive		7.0 × 2 (1.8 × 2)							
Hydraulic tank	Hydraulic oil	Tank; 230(61) System; 380(100)	ISO VG 32						
			ISO VG 46						
			ISO VG 68						
Fuel tank	Diesel fuel	520(137)	ASTM D975 NO.1						
			ASTM D975 NO.2						
Fitting (Grease nipple)	Grease	As required	NLGI NO.1						
			NLGI NO.2						
Radiator (Reservoir tank)	Mixture of antifreeze and water 50 : 50	45(12)	Ethylene glycol base permanent type						

SAE : Society of Automotive Engineers

API : American Petroleum Institute

ISO : International Organization for Standardization

NLGI : National Lubricating Grease Institute

ASTM : American Society of Testing and Material

4. MAINTENANCE CHECK LIST

1) DAILY SERVICE BEFORE STARTING

Check items	Service	Page
Visual check		
Fuel tank	Check, Refill	6-29
Hydraulic oil level	Check, Add	6-33
Engine oil level	Check, Add	6-18
Coolant level	Check, Add	6-21
Control panel & pilot lamp	Check, Clean	6-43
Water separator	Check, Drain	6-30
Fan belt tension	Check, Adjust	6-27

2) EVERY 50 HOURS SERVICE

Check items	Service	Page
Fuel tank	Drain	6-29
Track tension	Check, Adjust	6-38
Swing bearing	Lubricate	6-36
Swing reduction gear oil	Check, Add	6-36
Lubricate pin and bushing	Lubricate	6-42
<ul style="list-style-type: none"> · Boom cylinder tube end · Boom foot · Boom cylinder rod end · Arm cylinder tube end · Arm cylinder rod end · Boom + Arm connecting · Bucket cylinder tube end · Bucket cylinder rod end · Arm + Bucket connecting · Arm + Link, Bucket control · Bucket control rod 		

3) INITIAL 50 HOURS SERVICE

Check items	Service	Page
Engine oil	Change	6-18, 19
Engine oil filter	Replace	6-18, 19
Pilot line filter	Replace	6-35
Hydraulic return filter	Replace	6-34
Drain filter cartridge	Replace	6-35
Fuel filter	Replace	6-30
Bolts & Nuts	Check, Tight	6-8
· Sprocket mounting bolts		
· Travel motor mounting bolts		
· Swing motor mounting bolts		
· Swing bearing mounting bolts		
· Engine mounting bolts		
· Counterweight mounting bolts		
· Turning joint locating bolts		
· Track shoe mounting bolts and nuts		
· Hydraulic pump mounting bolts		

Service the above items only for the new machine, and thereafter keep the normal service interval.

4) EVERY 100 HOURS SERVICE

Check items	Service	Page
Return filter	Replace	6-34
Pilot line filter	Replace	6-35
Element in hydraulic tank breather	Replace	6-35
Drain filter cartridge	Replace	6-35

Replace 4 filters for continuous hydraulic breaker operation only.

5) EVERY 250 HOURS SERVICE

Check items	Service	Page
Battery electrolyte	Check, Add	6-43
Hydraulic oil return filter	Replace	6-34
Drain filter cartridge	Replace	6-35
★ Swing reduction gear oil	Change	6-36
★ Swing reduction grease	Check, Add	6-36
Pilot line filter	Replace	6-35
Charge air cooler	Check, Replace	6-25
Element in hydraulic tank breather	Replace	6-35
Bolts & Nuts	Check, Tight	6-8
· Sprocket mounting bolts		
· Travel motor mounting bolts		
· Swing motor mounting bolts		
· Swing bearing mounting bolts		
· Engine mounting bolts		
· Counterweight mounting bolts		
· Turning joint locating bolts		
· Track shoe mounting bolts and nuts		
· Hydraulic pump mounting bolts		

★ Change oil and add grease after initial 250 hours of operation.

6) EVERY 500 HOURS SERVICE

Check items	Service	Page
★ Engine oil	Change	6-18, 19
★ Engine oil filter	Replace	6-18, 19
Radiator and cooler fin	Inspect, Clean	6-25
☆ Air cleaner element	Check, Clean	6-29
Fuel filter	Replace	6-30
Corrosion resistor	Replace	6-20
Travel reduction gear oil	Check, Add	6-37
◆ Travel reduction gear oil	Change	6-37

★ If you use high sulfur containing fuel above than 0.5% or use low grade of engine oil reduce change interval.

☆ Clean the primary element only after 500 hours operation or when the air cleaner warning lamp blinks. Replace primary element and safety element after 4 times cleanings of primary element.

◆ Change oil after initial 500 hours of operation.

7) EVERY 1000 HOURS SERVICE

Check items	Service	Page
Forn belt tensioner	Check, Replace	6-27
Travel motor reduction gear oil	Change	6-37
Swing reduction gear oil	Change	6-36
Swing reduction grease	Refill	6-36
Grease in swing gear and pinion	Change	6-37

8) EVERY 2000 HOURS SERVICE

Check items	Service	Page
Hydraulic tank		
· Oil	Change	6-23
· Suction strainer	Check, Clean	6-34
Coolant	Change	6-22, 23, 24, 25

Change oil every 600 hours of continuous hydraulic breaker operation.

9) WHEN REQUIRED

Whenever you have trouble in the machine, you must perform the service of related items, system by system.

Check items	Service	Page
Fuel system		
· Fuel tank	Drain or Clean	6-29
· Water separator	Drain or Replace	6-30
· Fuel filter	Replace	6-30
Engine lubrication system		
· Engine oil	Change	6-18, 19
· Engine oil filter	Replace	6-18, 19
Engine cooling system		
· Coolant	Add or Change	6-22, 23, 24, 25
· Radiator	Clean or Flush	6-22, 23, 24, 25
Engine air system		
· Air cleaner element	Replace	6-29
Hydraulic system		
· Hydraulic oil	Add or Change	6-33
· Return filter	Replace	6-34
· Drain line filter	Replace	6-35
· Pilot line filter	Replace	6-35
· Element of breather	Replace	6-35
· Suction strainer	Clean	6-34
Undercarriage		
· Track tension	Check, Adjust	6-38
Bucket		
· Tooth	Replace	6-40
· Side cutter	Replace	6-40
· Linkage	Adjust	6-41
· Bucket assy	Replace	6-39
Air conditioner and heater		
· Fresh filter	Clean, Replace	6-46
· Recirculation filter	Clean	6-47

5. MAINTENANCE CHART

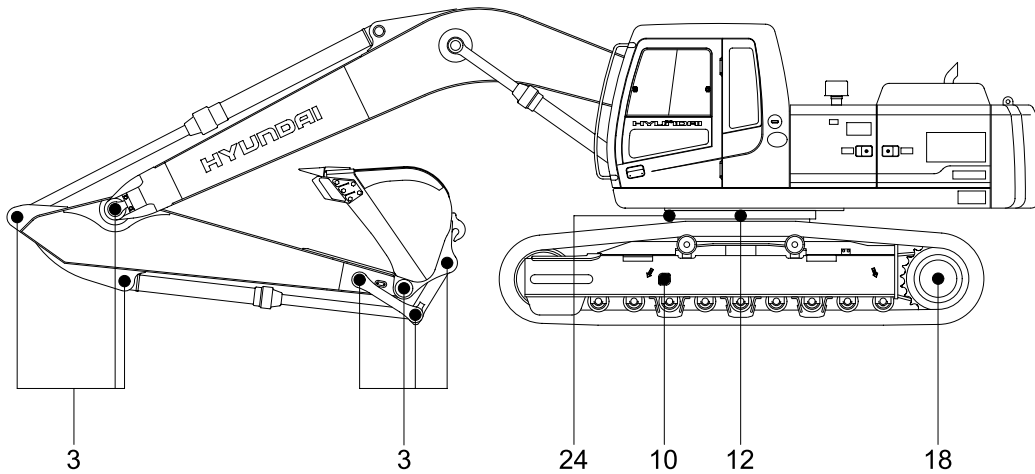
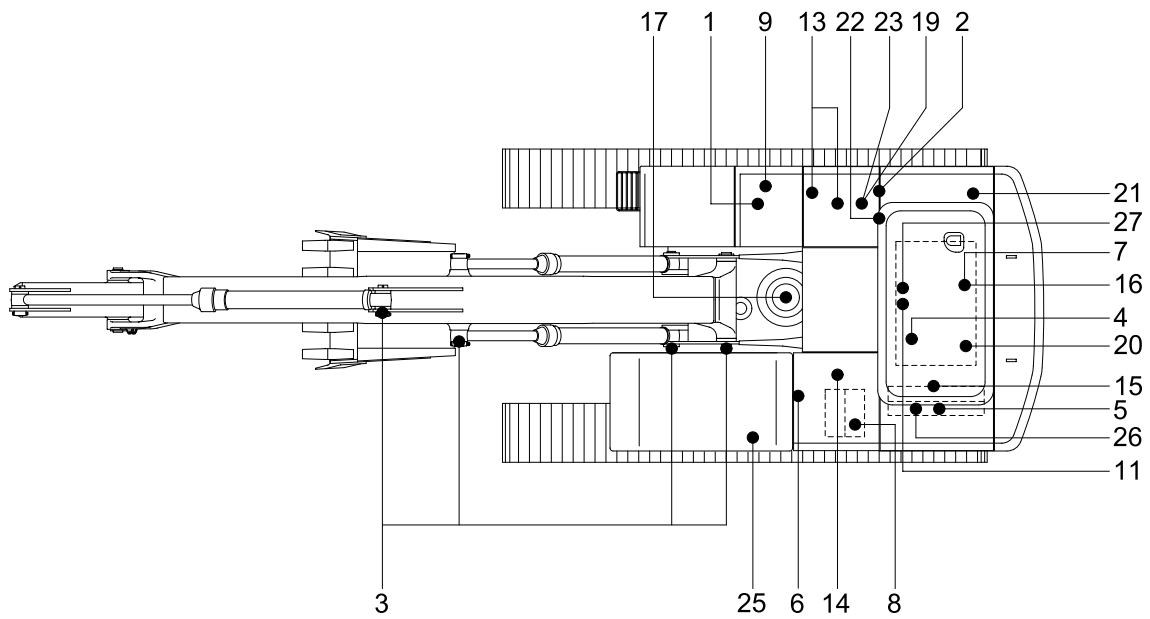

36076MI05

Caution

1. Service intervals are based on the hour meter reading.
2. The number of each item shows the lubrication point on the machine.
3. Stop engine while filling oil, and use no open flames.
4. For other details, refer to the service manual.

Service interval	No.	Description	Service action	Oil symbol	Capacity l (U.S.gal)	Service points No.
10 Hours or daily	1	Fuel tank	Check, Refill	DF	520(137)	1
	2	Hydraulic oil level	Check, Add	HO	230(61)	1
	4	Engine oil level	Check, Add	EO	26.5(7.0)	1
	5	Radiator coolant	Check, Add	C	45(12)	1
	6	Control panel & pilot lamp	Check, Clean	-	-	1
	7	Water separator	Check, Drain	-	-	1
50 Hours or weekly	3	Attachment pins	Check, Add	PGL	-	17
	9	Fuel tank strainer and drain	Check, Clean	-	-	1
	10	Track tension	Check, Adjust	PGL	-	2
	12	Swing bearing grease	Check, Add	PGL	-	3
	17	Swing drive gear case	Check, Add	GO	6(1.6)	1
250 Hours	8	Battery(Electrolyte)	Check, Add	-	-	2
	13	Hydraulic oil return filter	Replace	-	-	1
	21	Line filter element	Replace	-	-	1
	22	Drain filter cartridge	Replace	-	-	2
	23	Air breather element	Replace	-	-	1
	26	Charge air cooler	Check, Replace	-	-	1
500 Hours	4	Engine oil level	Change	EO	26.5(7.0)	1
	11	Engine oil filter	Replace	-	-	1
	14	Air cleaner element	Clean	-	-	2
	15	Radiator and cooler fin	Check, Clean	-	-	1
	16	Fuel filter element	Replace	-	-	2
	18	Final drive gear case	Check, Add	GO	7(1.8)	2
	27	Corrosion resistor	Replace	-	-	1
1000 Hours	17	Swing drive gear case	Change	GO	6(1.6)	1
	18	Final drive gear case	Change	GO	7(1.8)	2
	20	Fan belt tensioner, auto adjustable	Check, Replace	-	-	1
	24	Swing gear and pinion	Change	PGL	12.8(3.4)	1
2000 Hours	2	Hydraulic oil level	Change	HO	230(61)	1
	5	Radiator coolant	Change	C	45(12)	1
	19	Hydraulic oil suction strainer	Check, Clean	-	-	1
As required	25	Air conditioner filters	Check, Clean	-	-	2

※ **Oil symbol**

Please refer to the recommended lubricants for specification.

DF : Diesel fuel

GO : Gear oil

HO : Hydraulic oil

C : Coolant

PGL : Grease

EO : Engine oil

6. SERVICE INSTRUCTION

1) CHECK ENGINE OIL LEVEL

Check the oil level with the machine on a flat ground before starting engine.

- (1) Pull out the dipstick and wipe with a clean cloth.
 - (2) Check the oil level by inserting the dipstick completely into the hole and pulling out again.
 - (3) If oil level is LOW, add oil and then check again.
 - ※ If the oil is contaminated or diluted, change the oil regardless of the regular change interval.
 - ※ Check oil level after engine has been stopped for 15 minutes.
- ▲ Do not operate unless the oil level is in the normal range.

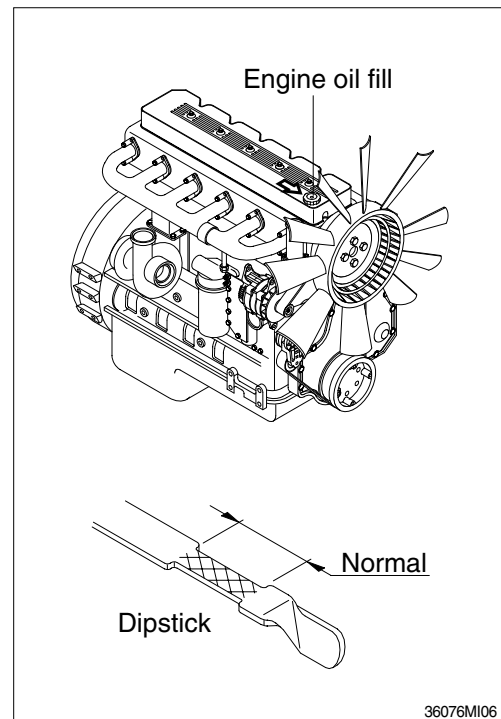

2) REPLACEMENT OF ENGINE OIL AND OIL FILTER

- (1) Warm up the engine.
 - (2) Remove the plug and allow the oil to drain.
 - Wrench size : 17mm
- ※ A drain pan with a capacity of 28 liters (7.4U.S. gallons) will be adequate.

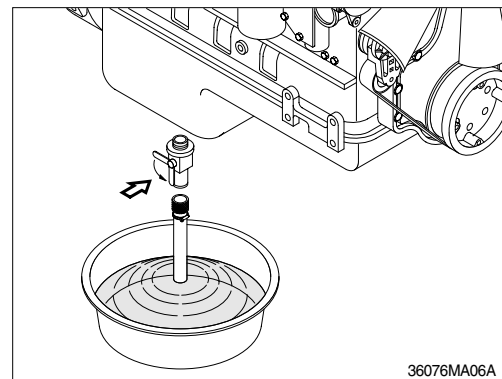

- (3) Clean around the filter head, remove the filter and clean the gasket surface.
 - Wrench size : 75 ~ 85mm(3.0~3.3in)
- ※ The o-ring can stick on the filter head. Make sure it is removed before installing the new filter.

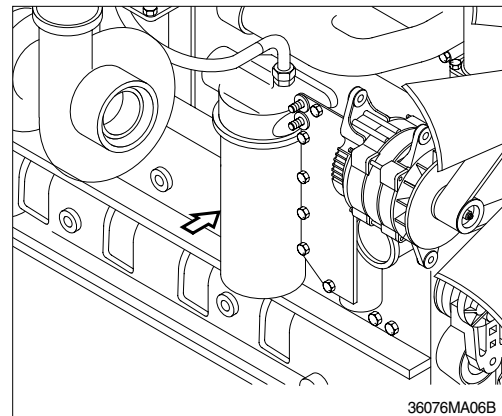

- (4) Apply a light film of lubricating oil to the gasket sealing surface before installing the filters.
Fill the filters with clean lubricating oil.

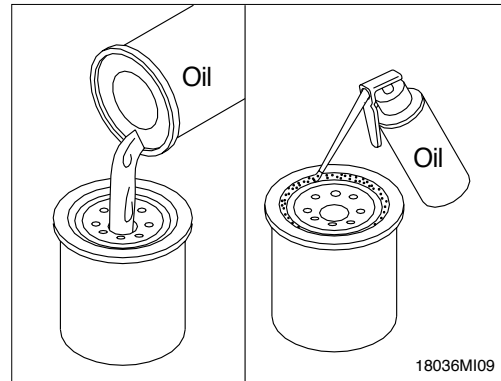

- (5) Install the filter to the filter head.
Mechanical over-tightening may distort the threads or damage the filter element seal.
- Install the filter as specified by the filter manufacturer.

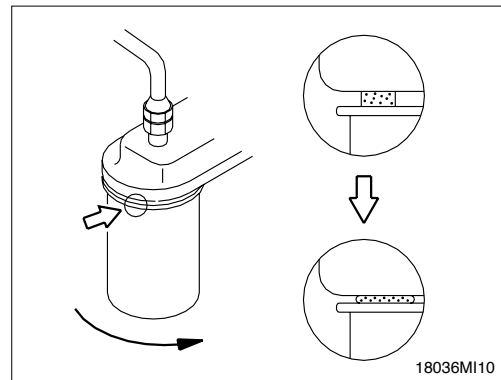

- (6) Fill the engine with clean oil to the proper level.
- Quantity : 19.9 (5.3U.S.gallons)

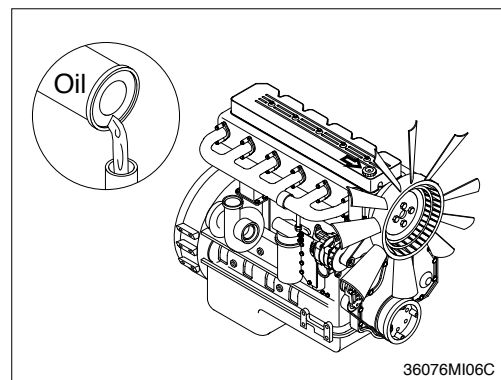

- (7) Operate the engine at low idle and inspect for leaks at the filters and the drain plug.
Shut the engine off and check the oil level with the dipstick. Allow 15minutes for oil to drain down before checking.

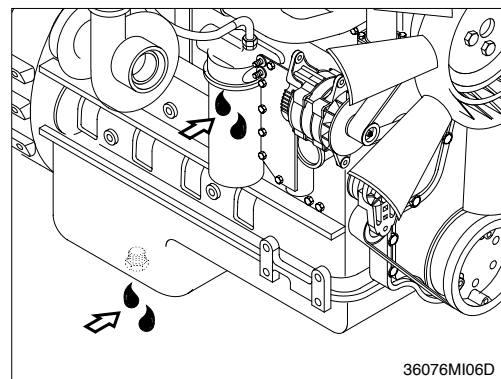

3) REPLACEMENT OF WATER FILTER

- (1) Turn the shutoff valve to the OFF position by rotating the knob from vertical to horizontal as figure.

▲ Wait until the temperature is below 50. C (122. F) before removing the radiator cap. Remove the coolant system radiator cap and close the shutoff valve before removing the water filter. Failure to do so can result in personal injury from heated coolant spray.

- (2) Remove and discard the water filter. Clean the gasket surface.

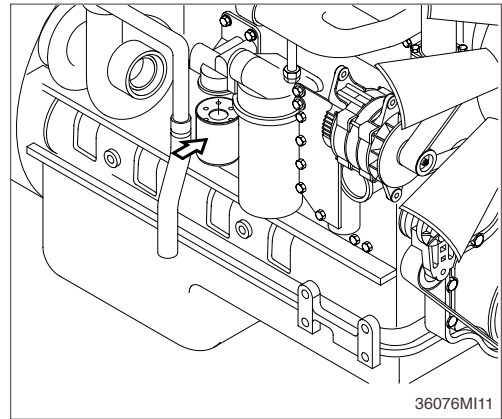
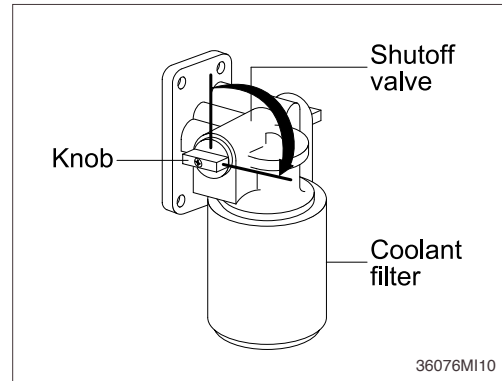

- (3) Apply a thin film of lubricating oil to the gasket sealing surface before installing the new water filter.

▲ Do not allow oil to get into the filter. Oil will damage the DCA.

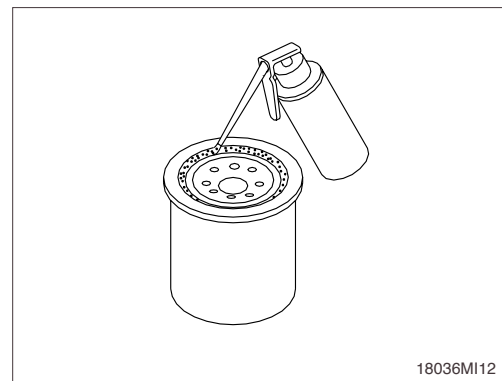

- (4) Install the water filter on the filter head. Tighten the filter until the gasket contacts the filter head surface.

Tighten the water filter an additional 1/2 to 3/4 of a turn or as specified by the filter manufacturer.

▲ Mechanical overtightening can distort the threads or damage the filter head.

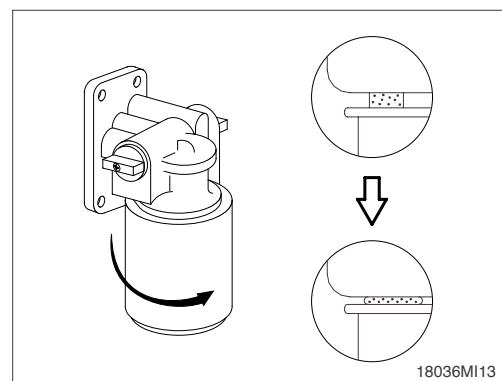

- (5) Install the radiator cap.
- (6) Operate the engine until it reaches a temperature 80. C (176. F) and check for coolant leaks.

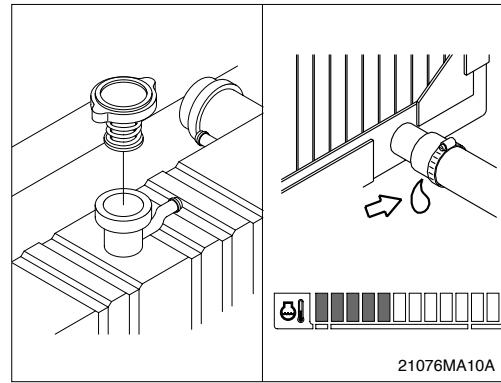

4) CHECK COOLANT

- (1) Check if the level of coolant in reservoir tank is between FULL and LOW.
- (2) Add the mixture of antifreeze and water after removing the cap of the reservoir tank if coolant is not sufficient.
- (3) Be sure to use the reservoir empty, add the coolant by opening the cap of radiator.
- (4) Replace gasket of radiator cap when it is damaged.

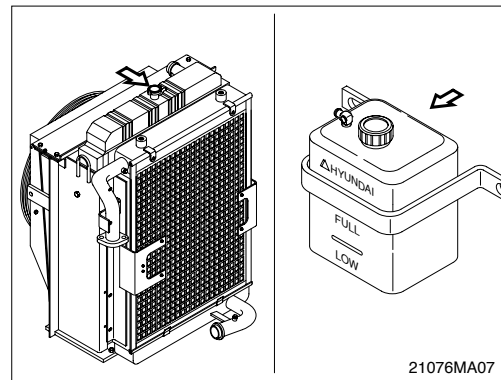

- ▲ **Hot coolant can spray out if radiator cap is removed while engine is hot. Remove the cap after the engine has cooled down.**

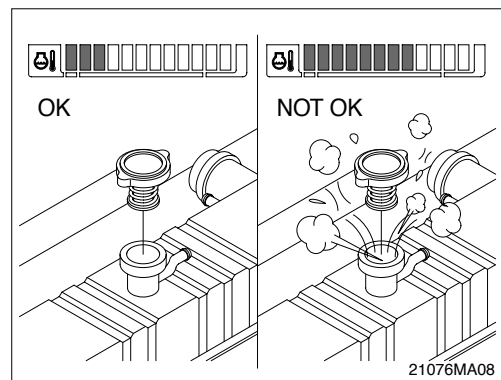

5) FLUSHING AND REFILLING OF RADIATOR

(1) Change coolant

⚠ Avoid prolonged and repeated skin contact with used antifreeze. Such prolonged repeated contact can cause skin disorders or other bodily injury.

Avoid excessive contact-wash thoroughly after contact.

Keep out of reach of children.

Protect the environment : Handling and disposal of used antifreeze can be subject to federal, state, and local law regulation.

Use authorized waste disposal facilities, including civic amenity sites and garages providing authorized facilities for the receipt of used antifreeze.

If in doubt, contact your local authorities for guidance as to proper handling of used antifreeze.

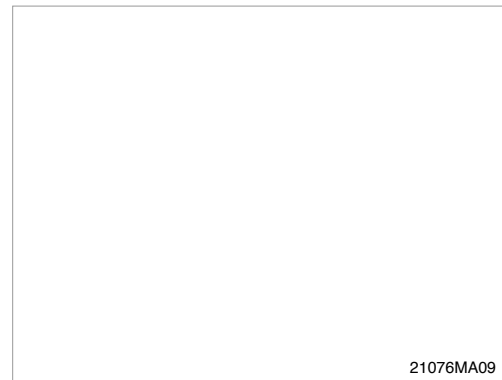
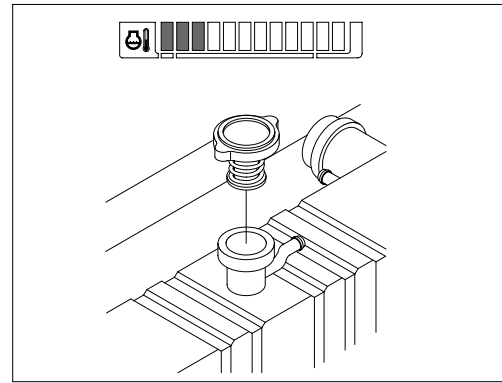

21076MA09

⚠ Wait until the temperature is below 50.C (122.F) before removing the coolant system pressure cap.

Failure to do so can cause personal injury from heated coolant spray.

Drain the cooling system by opening the drain valve on the radiator and removing the plug in the bottom of the water inlet. A drain pan with a capacity of 45 liters(12U.S.gallons) will be adequate in most applications.

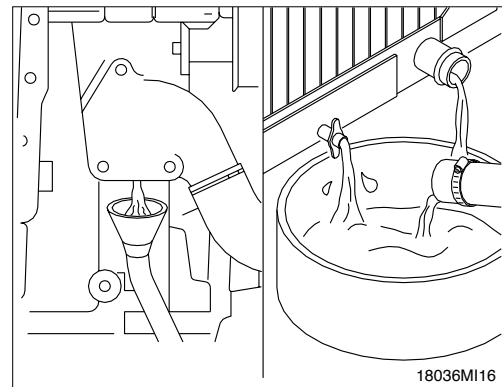

18036MI16

(2) Flushing of cooling system

Fill the system with a mixture of sodium carbonate and water(or a commercially available equivalent).

Use 0.5kg(1.0pound) of sodium carbonate for every 23 liters(6.0U.S. gallons) of water.

Do not install the radiator cap. The engine is to be operated without the cap for this process.

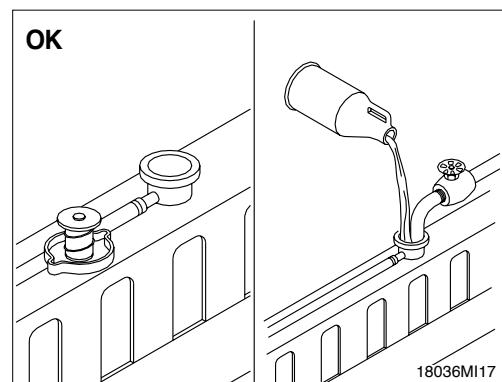

18036MI17

During filling, air must be vented from the engine coolant passages. Open the engine venting petcock.

The system must be filled slowly to prevent air locks. Wait 2 to 3 minutes to allow air to be vented, then add mixture to bring the level to the top.

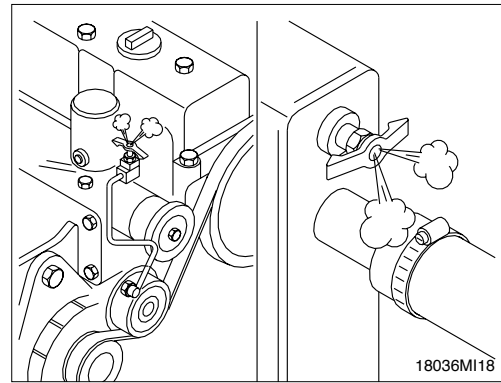

Operate the engine for 5 minutes with the coolant temperature above 80°C(176°F) . Shut the engine off, and drain the cooling system.

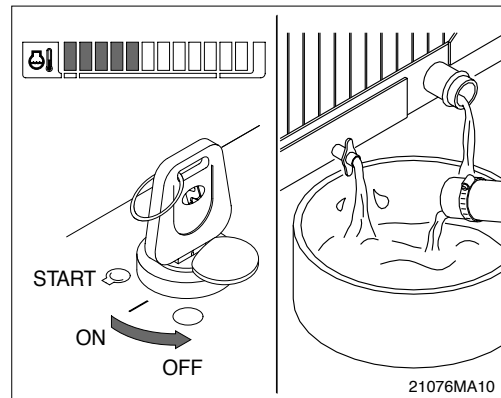

Fill the cooling system with clean water. **Be sure to vent the engine and aftercooler for complete filling.** Do not install the radiator cap or the new coolant filter.

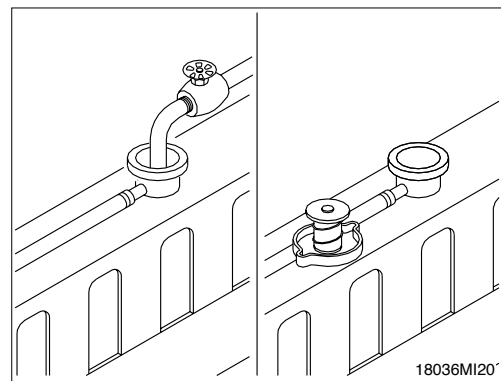

Operate the engine for 5 minutes with the coolant temperature above 80°C(176°F) . Shut the engine off, and drain the cooling system.

If the water being drained is still dirty, the system must be flushed again until the water is clean.

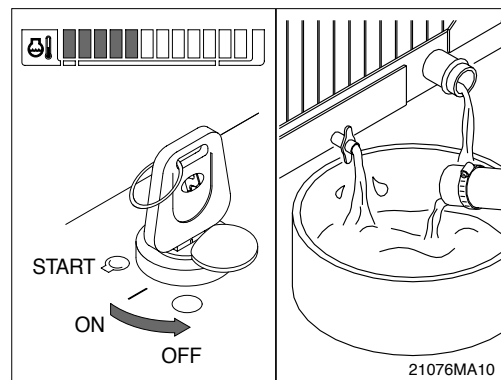

(3) Cooling system filling

Use a mixture of 50 percent water and 50 percent ethylene glycol antifreeze to fill the cooling system.

Coolant capacity(engine only) : 10.4 (2.7U.S. gallons)

Use the correct amount of DCA4 corrosion inhibitor to protect the cooling system.

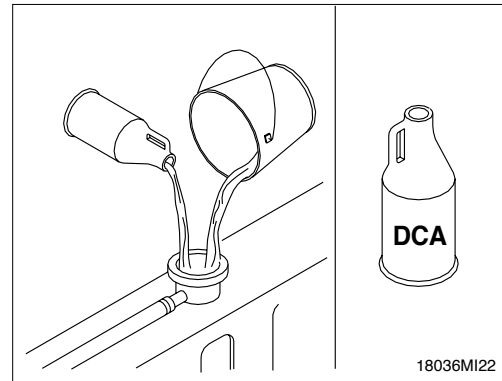

The system has a maximum fill rate of 19 liters(5.0U.S. gallons)

Do not exceed this fill rate.

The system must be filled slowly to prevent air locks.

During filling, air must be vented from the engine coolant passage.

Be sure to open the petcock.

Then add mixture to bring the level to the top.

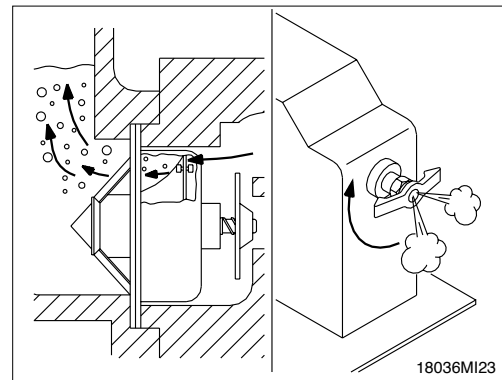

Install the pressure cap. Operate the engine until it reaches a temperature 80°C(176°F), and check for coolant leaks.

Check the coolant level again to make sure the system is full of coolant.

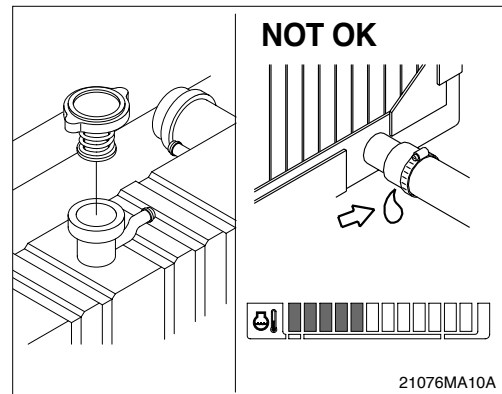

6) CLEAN RADIATOR AND OIL COOLER

Check, and if necessary, clean and dry outside of radiator and oil cooler. After working in a dusty place, clean radiator more frequently.

- (1) Visually inspect the radiator for clogged radiator fins.
- (2) Use 550kPa(80psi) air pressure to blow the dirt and debris from the fins.
Blow the air in the opposite direction of the fan air flow.
- (3) Visually inspect the radiator for bent or broken fins.
If the radiator must be replaced due to bent or broken fins which can cause the engine to overheat, refer to the manufacturer's replacement procedures.
- (4) Visually inspect the radiator for core and gasket leaks.

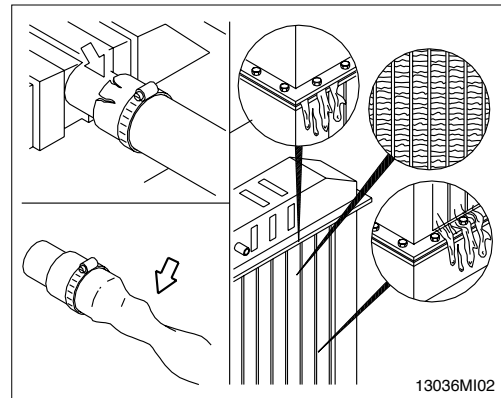
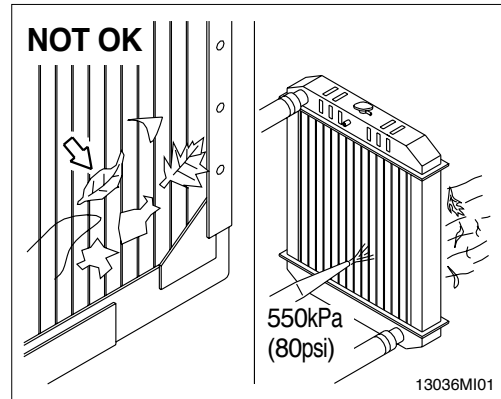

7) CHECK CHARGE AIR COOLER

Inspect the charge air cooler for dirt and debris blocking the fins. Check for cracks, holes, or other damage. If damage is found, please contact Hyundai distributor.

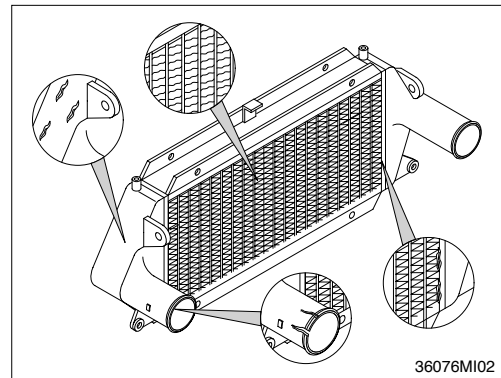

8) FAN BELT TENSION

(1) Inspect the drive for damage.

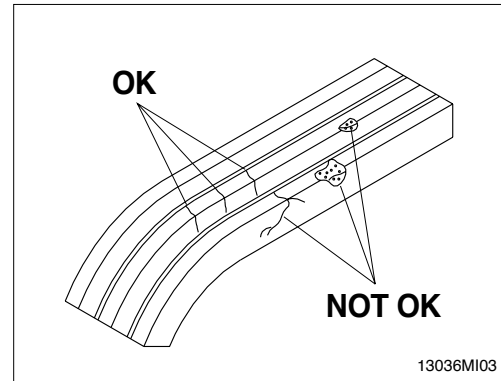

(2) Inspect the drive belt and fan hub.

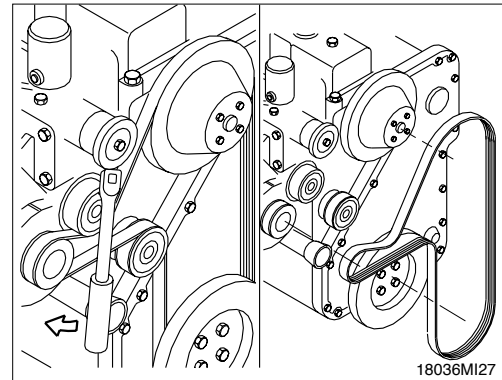

9) INSPECTION OF COOLING FAN

▲ Personal injury can result from a fan blade failure. Never pull or pry on the fan. This can damage the fan blade and cause fan failure.

Rotate the crankshaft by using the engine barring gear.

A visual inspection of the cooling fan is required daily.

Check for cracks, loose rivets, and bent or loose blades.

Check the fan to make sure it is securely mounted. Tighten the capscrews if necessary.

Replace any fan that is damaged.

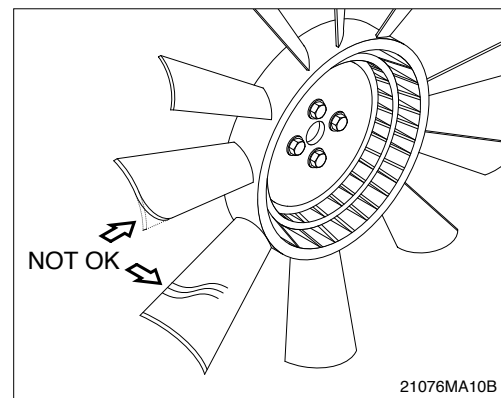

10) BELT TENSIONER, AUTOMATIC Adjustment

- (1) Every 1000hours, or 1 year, whichever occurs first, inspect the automatic belt tensioner.

With the engine turned off, check that neither the top nor bottom tensioner arm stop is touching the cast boss on the tensioner body. If either of the stops is touching a boss, the alternator belt must be replaced. Check to make sure the correct belt part number is being used if either condition exists.

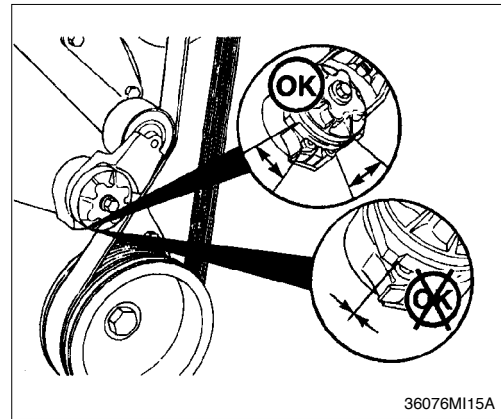

- (2) Check the tensioner pulley and body for cracks. If any cracks are noticed, the tensioner must be replaced. Refer to a Cummins Authorized Repair facility. Check the tensioner for dirt buildup. If this condition exists, the tensioner must be removed and steam-cleaned.

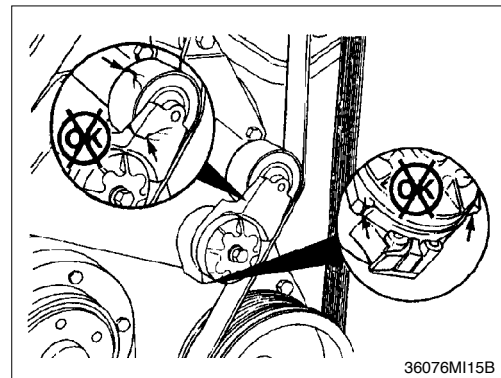

- (3) Check that the bottom tensioner arm stop is in contact with the bottom tensioner arm stop boss on the tensioner body. If these two are not touching, the tensioner must be replaced.

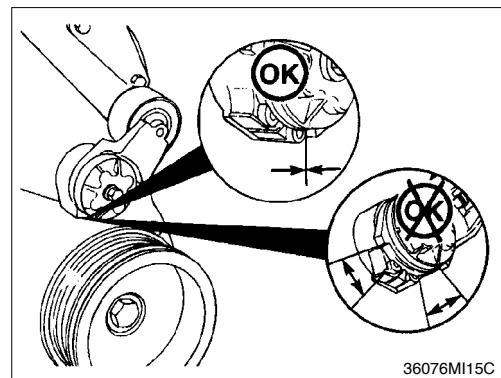

- (4) Inspect the tensioner for evidence of the pivoting tensioner arm contacting the stationary circular base. If there is evidence of these two areas touching, the pivot tube bushing has failed and the tensioner must be replaced.

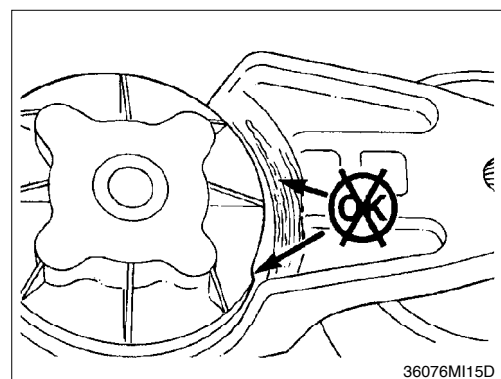

- (5) A worn tensioner that has play in it or a belt that “walks” off its pulley possibly indicates pulley misalignment.

Maximum pulley mislignment is three degrees. This measurement can be taken with a straightedge and an inclinometer.

- (6) Install the belt.

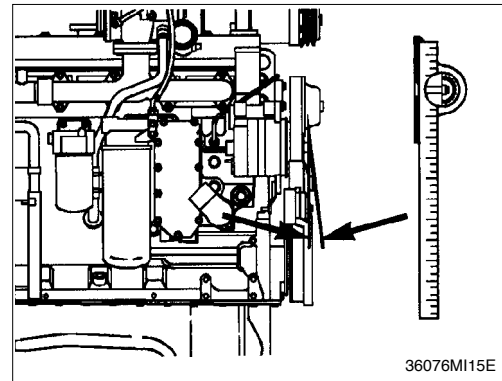

11) CLEANING OF AIR CLEANER

(1) Primary element

Loosen the wing nut and remove the element.

Clean the inside of the body.

Clean the element with pressurized air.

- Remove the dust inside of the element by the pressurized air (Below 3kgf/cm^2 , 40psi) forward and backward equally.

Inspect for cracks or damage of element by putting a light bulb inside of the element.

Insert element and tighten wing nut.

Replace the primary element after 4 times cleanings.

(2) Safety element

Replace the safety element only when the primary element is cleaned for the 4 times.

Always replace the safety element. Never attempt to reuse the safety element by cleaning the element.

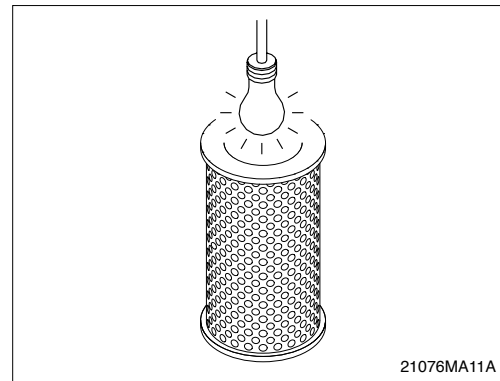
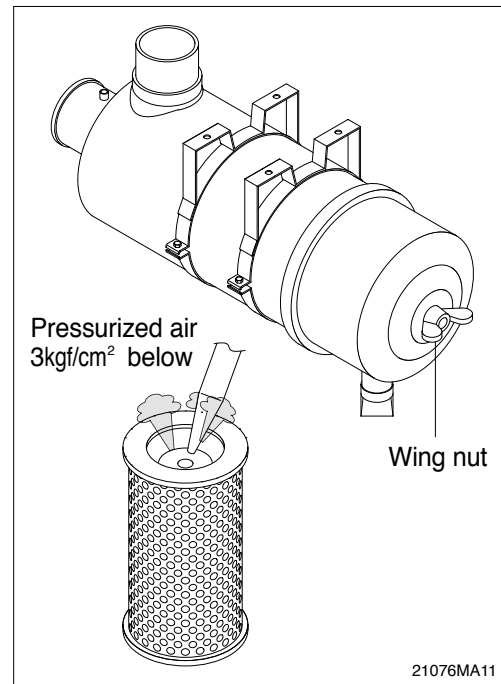

12) FUEL TANK

- (1) Fill fuel fully when system the operation to minimize water condensation, and check it with fuel gauge before starting the machine.

- (2) Drain the water and sediment in the fuel tank by opening the drain cock.

Be sure to LOCK the cap of fuel tank.

Remove the strainer of the fuel tank and clean it if contaminated.

- ⚠ **Stop the engine when refueling.**

All lights and flames shall be kept at a safe distance while refueling.

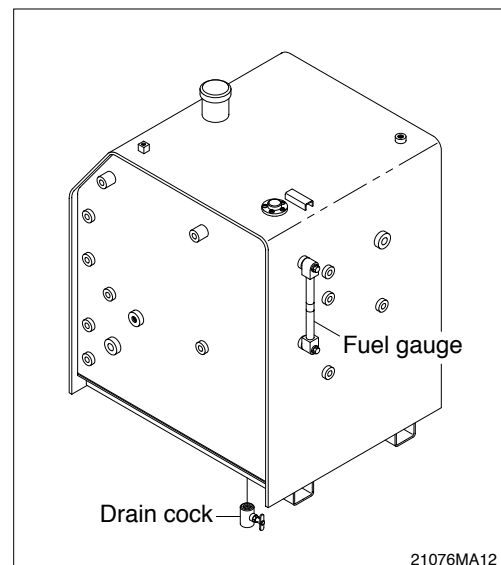

13) REPLACEMENT OF FUEL FILTER

- (1) Disconnect wiring harness from water sensor.
- (2) Clean around the filter head, remove the filter and clean the gasket surface.
 - Wrench size : 75~85mm(3.0~3.3in)

Make sure O-ring does not stick to filter head.
Remove O-ring with screwdriver if necessary.

- (3) Install the water sensor into the new fuel filter.

▲ This engine has a self-priming, low pressure system that purges the air from the fuel system.

Do not prefill the fuel filter. Prefilling the fuel filter can cause fuel pump damage.

- (4) Lubricate the O-ring with clean lubricating oil.
- (5) Install the filter to the filter head.
Tighten 3/4 of a turn after contact.

Mechanical overtightening can distort the threads or damage the filter element seal.

- (6) Connect the water sensor to the wiring harness.
Check for fuel leakage after the engine starts.

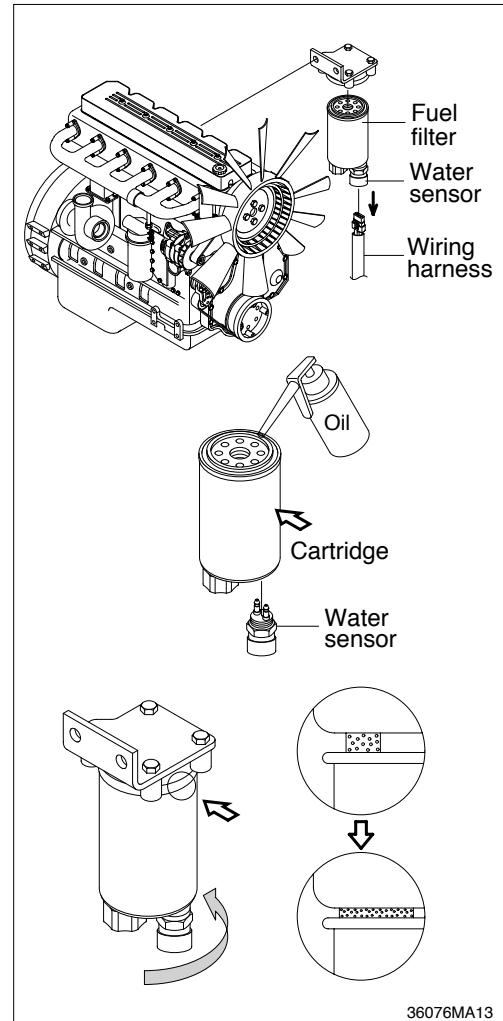

FUEL WATER SEPARATOR

- ▲ Water can contain toxic and carcinogenic material.**
- ▲ Drain the water/fuel into a container and dispose of in accordance with local environmental regulations.**

Drain the water and sediment from the separator daily.

Shut off the engine.

Use your hand to open the drain valve.

Open the drain valve until fluid drains out of the drain tube.

Drain the filter sump until clear fuel is visible.

Drain the water when the engine check pilot lamp blinks and fault code 418 on the cluster.

Refer to service manual for fault code.

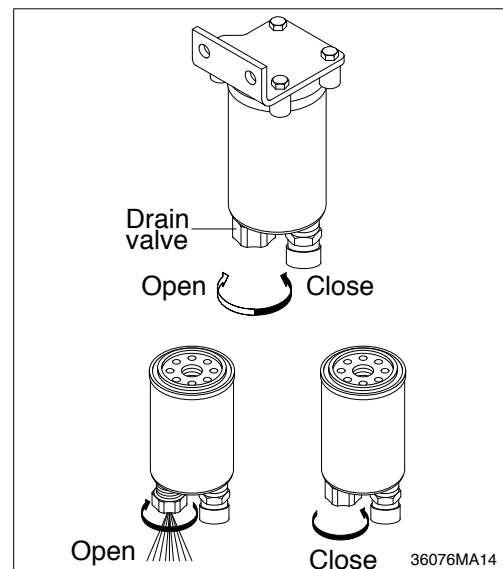

14) BLEEDING THE FUEL SYSTEM

(1) Air in fuel

The air bleed fitting on the fuel system creates a self bleeding system during replacement of the supply side components. High pressure fuel line removal and replacement will not require external bleeding to start the engine.

The fuel pump will create high fuel pressure during cranking and purge the air in the high pressure side through the injectors.

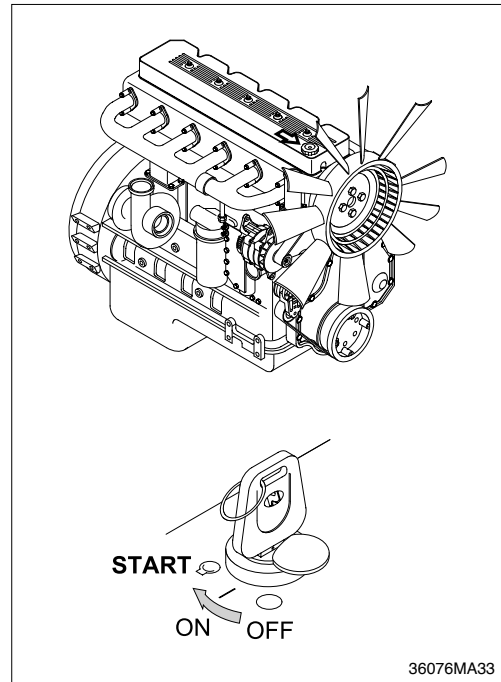

If an excessive amount of air has entered the system, the system will need to be bled. Loosen the fuel supply line at the pump. Run the electric fuel lift pump until the air has been bled. When all the air has been bled, tighten the fitting.

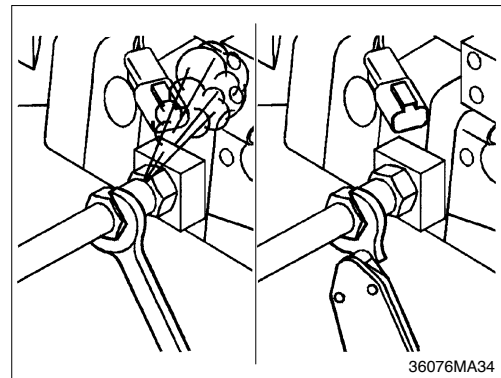

Supply line leaks from the lift pump to the fuel pump can be located by operating the lift pump or keyswitch cycling, to build pressure in the fuel lines. Inspect all lines and connections, as well as the fuel filter assembly, for an external fuel leak.

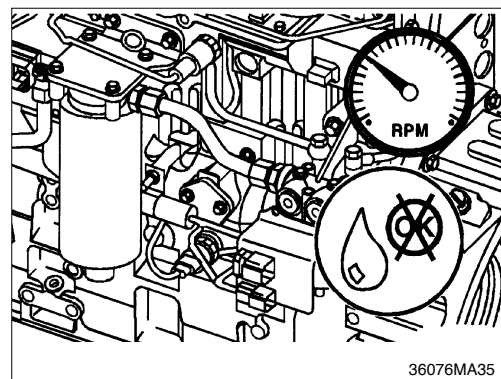

A stuck open injector can also blow combustion gas back into the pump and cause air to be present in the overflow.

If the engine seems to be misfiring or running rough, break all the injector supply lines loose at the pump end. Crank the engine and observe the lines. If combustion gas seems to be blowing back through the line, the injector is stuck open.

Use two wrenches when loosening the lines at the fuel pump, one to hold the delivery valve and one to loosen the line.

- Wrench size : 19mm
- Tightening torque : 2.45kgf · m(18lbf · ft)

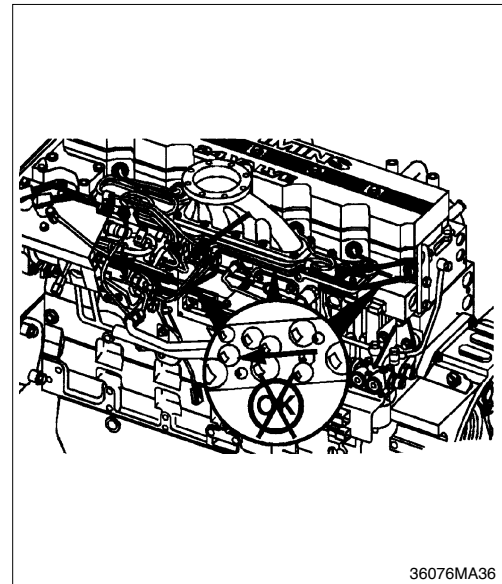

(2) Venting the high pressure lines

▲ The pressure of the fuel in the line is sufficient to penetrate the skin and cause serious bodily harm.

Loosen the fittings at the cylinder head and crank the engine to allow entrapped air to bleed from the line. Tighten the fittings.

- Wrench size : 19mm
- Torque : 3.9kgf · m(28lbf · ft)

Start the engine and vent one line at a time until the engine runs smoothly.

▲ Do not bleed a hot engine as this can cause fuel to spill onto a hot exhaust manifold, creating a danger of fire.

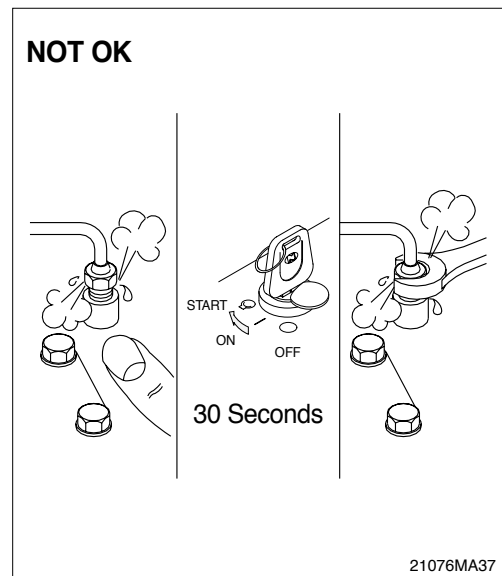

15) LEAKAGE OF FUEL

▲ Be careful and clean the fuel hose, injection pump, fuel filter and other connections as the leakage from these part can cause fire.

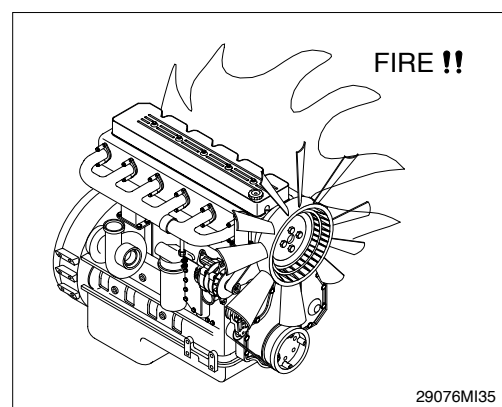

16) HYDRAULIC OIL CHECK

- (1) Stop the engine after retract the arm and bucket cylinders, then lower the boom and set the bucket on the ground at a flat location as in the illustration.
- (2) Check the oil level at the level gauge of hydraulic oil tank.
- (3) The oil level is normal if between the red lines.

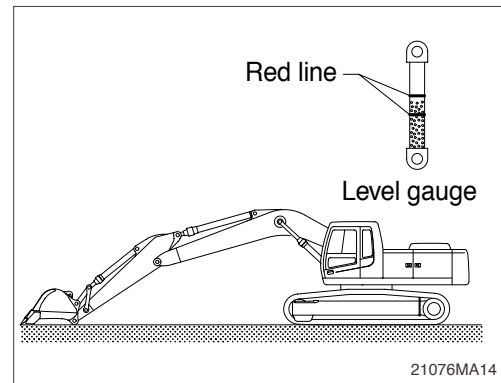

17) FILLING HYDRAULIC OIL

- (1) Stop the engine to the position of level check.
- (2) Relieve the pressure in the tank by loosening the air breather.
- (3) Remove the breather on the top of oil tank and fill the oil to the specified level.
- (4) Start engine after filling and operate the work equipment several times.
- (5) Check the oil level at the level check position after engine stops.

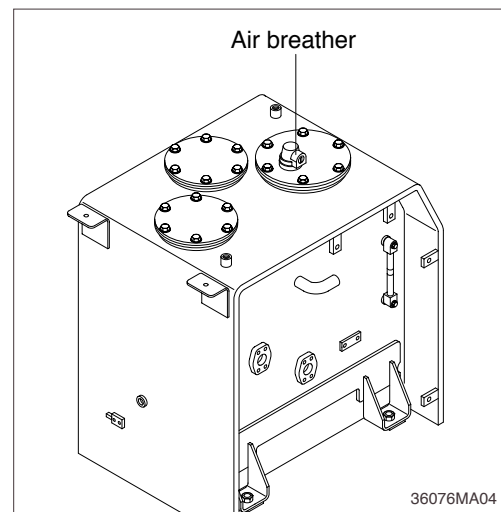

18) CHANGE HYDRAULIC OIL

- (1) Lower the bucket on the ground pulling the arm and bucket cylinder to the maximum.
- (2) Relieve the pressure in the tank by loosening the air breather.
- (3) Remove the cover.
 - Tightening torque : $6.9 \pm 1.4 \text{kgf} \cdot \text{m}$
($50 \pm 10 \text{lb} \cdot \text{ft}$)
- (4) Prepare a suitable container.
- (5) To drain the oil loosen the drain plug at the bottom of the oil tank.
- (6) Fill proper amount of recommended oil.
- (7) Put the breather in the right position.
- (8) **Bleed air hydraulic pump loosen the air breather at top of hydraulic pump assembly.**
- (9) Start engine and run continually. Release the air by full stroke of each control lever.

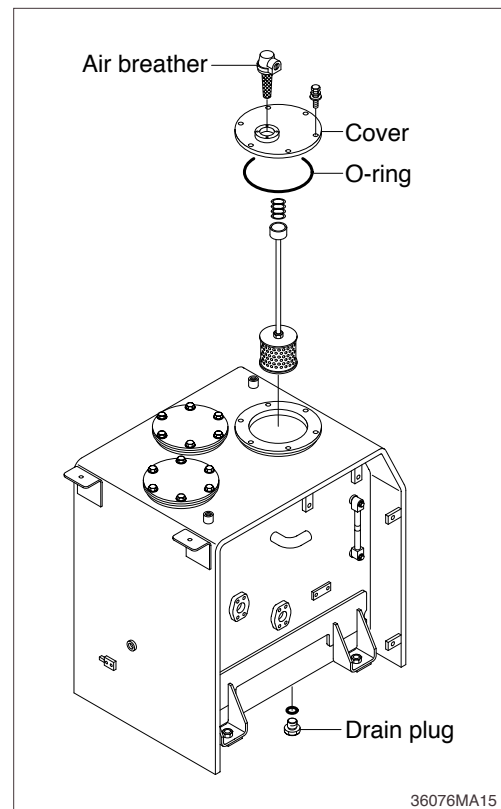

19) CLEAN SUCTION STRAINER

Clean suction strainer as follows paying attention to the cause to be kept during oil filling.

- (1) Remove the cover.
 - Tightening torque : $6.9 \pm 1.4\text{kgf} \cdot \text{m}$
($50 \pm 10\text{lbf} \cdot \text{ft}$)
- (2) Pull out the strainer in the tank.
- (3) Wash the foreign material on the suction strainer with gasoline or cleaning oil.
- (4) Replace the suction strainer if it is damaged.
- (5) Assemble with reverse order of disassembly.
Be sure to install a new O-ring and reinsert in the oil tank.

Loosen the bolt slowly at the cover can be spring out by the spring when removing it.

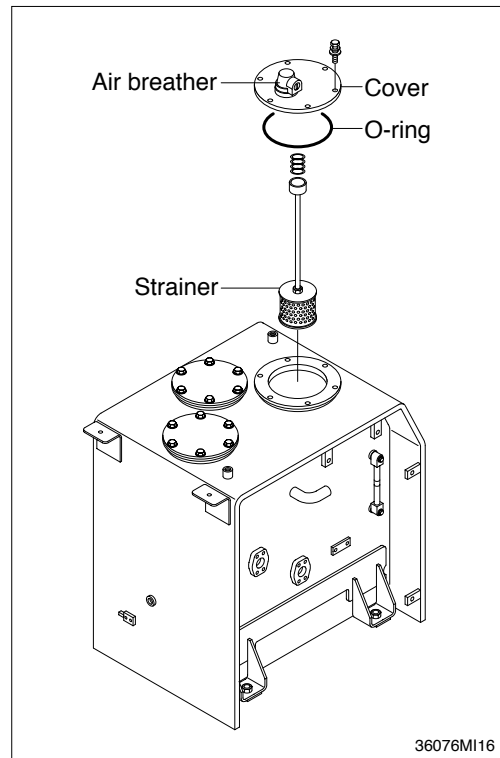

20) REPLACEMENT OF RETURN FILTER

Replace as follows paying attention to the cause to be kept during the replacement.

- (1) Remove the cover.
 - Tightening torque : $6.9 \pm 1.4\text{kgf} \cdot \text{m}$
($50 \pm 10\text{lbf} \cdot \text{ft}$)
- (2) Remove the spring, by-pass valve, and return filter in the tank.
- (3) Replace the element with new one.

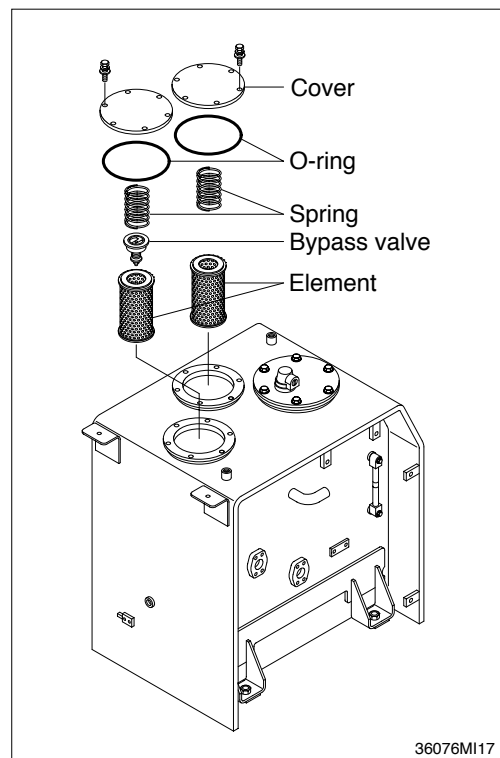

21) REPLACEMENT OF ELEMENT IN HYDRAULIC TANK BREATHER

- (1) Relieve the pressure in the tank by loosening the air breather.
- (2) Loosen the breather lock key.
- (3) Pull out the filter element.
- (4) Replace the filter element and O-ring with new one.
- (5) Reassemble by reverse order of disassembly.
 - Tightening torque : 0.7~0.9kgf · m
(5.0~6.5lbf · ft)

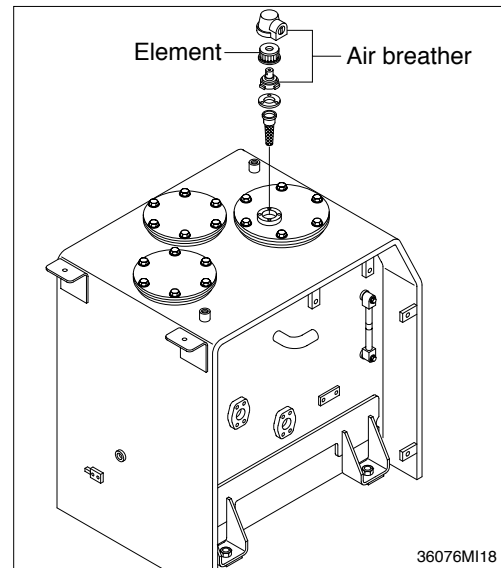

22) REPLACE OF DRAIN FILTER CARTRIDGE

Clean the dust around filter and replace with new one after removing the cartridge.

Tighten about 2/3 turn more after the gasket of cartridge contacts seal side of filter body for mounting.

Change cartridge after initial 50 hours of operation. Thereafter, change cartridge every 250 hours.

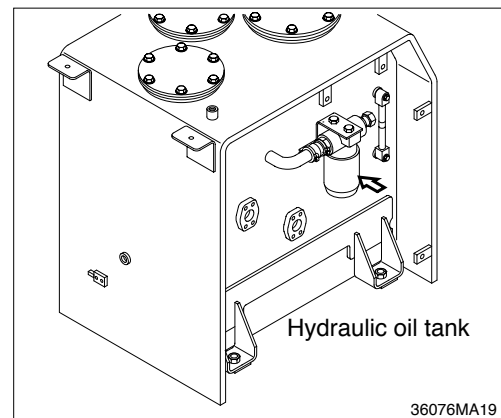

23) REPLACE OF PILOT LINE FILTER

- (1) Loosen the nut positioned on the filter body.
- (2) Pull out the filter element and clean filter housing.
- (3) Install the new element and tighten using specified torque.

Change cartridge after initial 50 hours of operation. Thereafter, change cartridge every 250 hours.

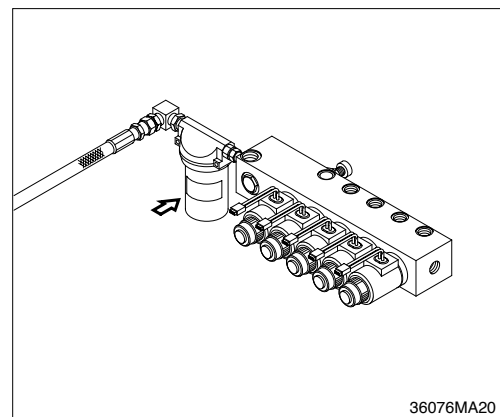

24) CHECK THE SWING REDUCTION GEAR OIL

- (1) Pull out the dipstick and clean it.
- (2) Insert it again.
- (3) Pull out one more time to check the oil level and fill the oil if the level is not sufficient.

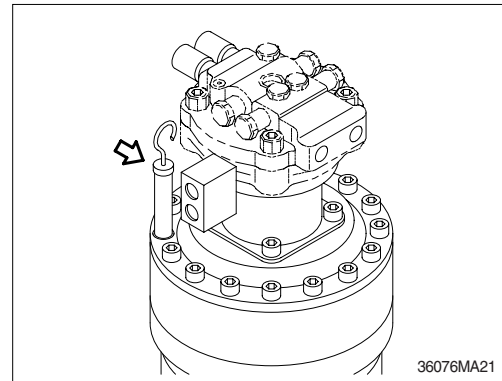

25) CHANGE SWING REDUCTION GEAR OIL

- (1) Raise the temperature of oil by swinging the machine before replace the oil and park the machine on the flat ground.
- (2) Loosen the plug of the drain port.
- (3) Drain into a proper container.
- (4) Wash the drain plug and reinstall it with sealing tape.
Fill proper amount of recommended oil.
· Amount of oil : 6.0 l (1.6U.S.gal)

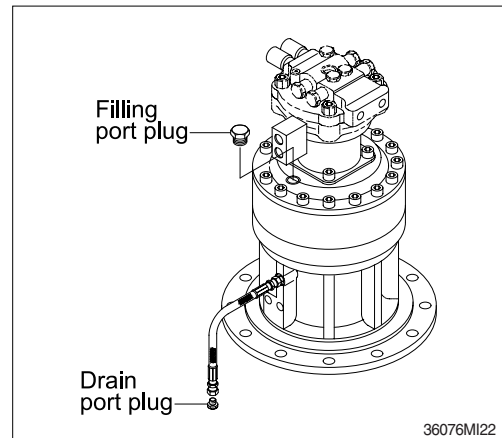

26) LUBRICATE BEARING OF OUTPUT SHAFT IN REDUCTION GEAR

- (1) Remove air vent plug.
 - (2) Remove grease fill plug and install grease fitting at that place.
 - (3) Lubricate NLGI No.2 with grease gun until comes out new grease from air vent port.
- ※ Lubricate every 1000 hours.

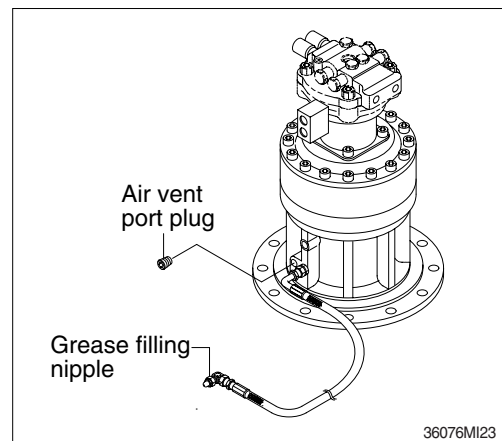

27) LUBRICATE SWING BEARING

- (1) Grease at 3 fitting.
- ※ Lubricate every 50 hours.

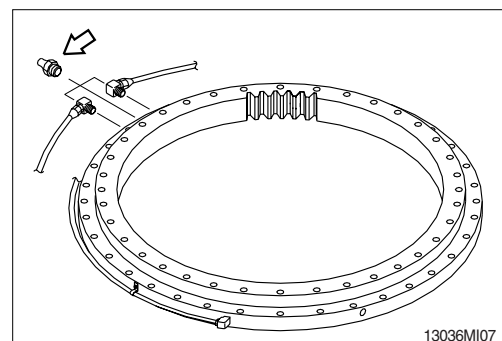

28) SWING GEAR AND PINION

(1) Drain old grease

- Remove under cover of lower frame.
- Remove drain cover of lower frame.
- Remove filler cover of upper frame.
- Operate full turn(360°) of swing several times.

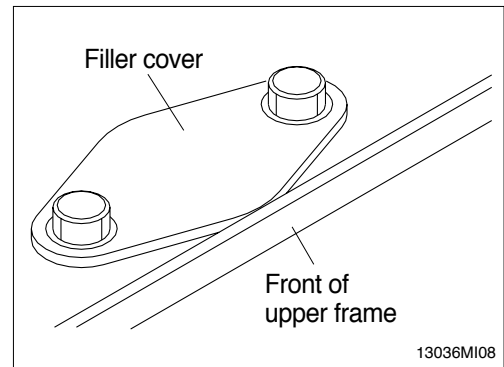

(2) Refill new grease

- Install drain cover.
- Fill with new grease.
- Install filler cover.
- Capacity : 11.5kg(25.4lb)

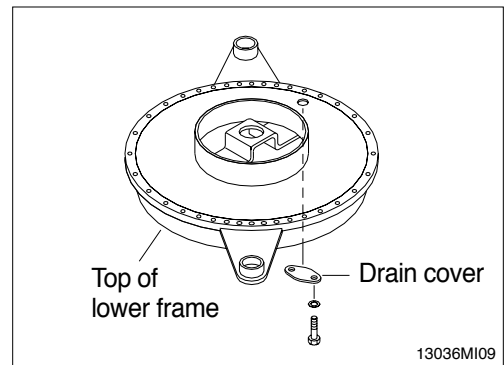

29) CHECK THE TRAVEL REDUCTION GEAR OIL

- (1) Operate the machine to the position of drain plug down to the flat ground.
- (2) Loosen the level plug and check the oil level.
If the level is at the hole of the plug, it is normal.
Fill the oil if it is not sufficient.

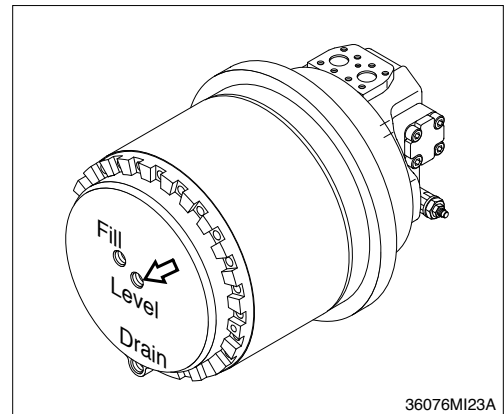

30) CHANGE OF THE TRAVEL REDUCTION GEAR OIL

- (1) Raise the temperature of the oil by traveling machine first.
- (2) Stop when the position of the drain plug is down.
- (3) Loosen the level plug and then the drain plug.
- (4) Drain the oil to adequate container.
- (5) Tighten the drain plug and fill specified amount of oil at filling port.
- (6) Tighten the level plug and travel slowly to check if there is any leakage of oil.

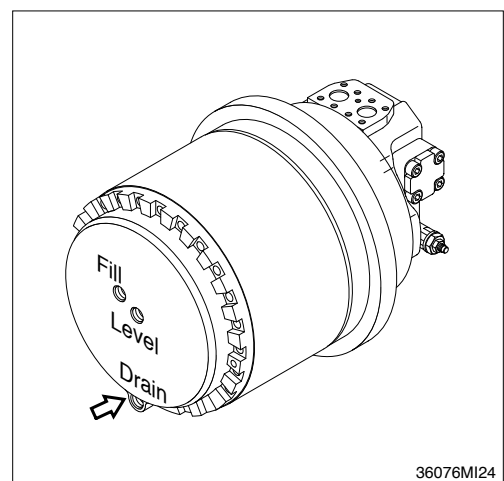

31) LUBRICATE RCV LEVER

Remove the bellows and with a grease gun grease the joint part(A) and sliding parts(B).

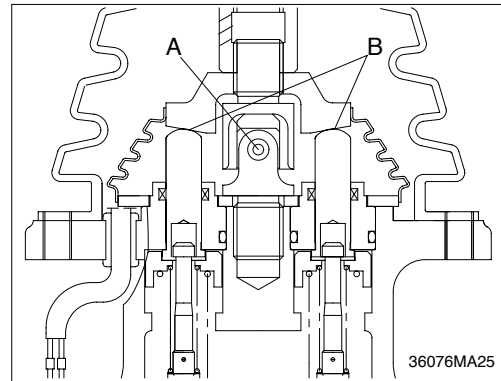

32) ADJUSTMENT OF TRACK TENSION

It is important to adjust the tension of track properly to extend the lifetime of track and traveling device.

The wear of pins and bushings on the undercarriage will vary with the working conditions and soil properties.

It is thus necessary to continually inspect the track tension so as to maintain the standard tension on it.

- (1) Raise the chassis with the boom and arm.
- (2) Measure the distance between bottom of track frame on track center and track of shoe.
Remove mud with rotating the track before measuring.

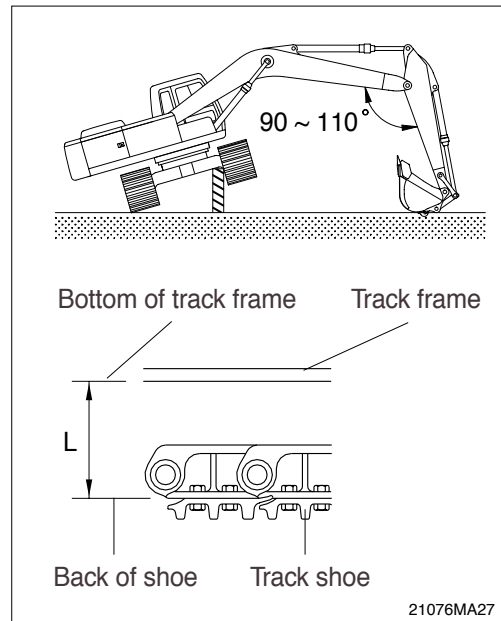

- (3) If the tension is tight, drain the grease in the grease nipple and if the tension is loose, charge the grease.

▲ Personal injury or death can result from grease under pressure.

▲ When loosening the grease nipple, do not loosen more than one turn as there is a danger of a spring coming out of the nipple because of the high pressure inside.

When the grease is drained, move the track to the forward and backward slightly.

If the track tension is loose even after the grease is charged to the maximum, change the pins and bushings as there are worn seriously.

Working condition	Length(L)	
	mm	inch
General	390~420mm	15.4~16.5"
Swamp	420~460mm	16.5~18.1"
Sand, Mud, pebbes	About460mm	About18.1"

33) REPLACEMENT OF BUCKET

▲ When knocking the pin in with a hammer, metal particles may fly and cause serious injury, particularly if they get into your eyes. When carrying out this operation, always wear goggles, helmet, gloves, and other protective equipment.

When the bucket is removed, place it in a stable condition.

When performing joint work, make sure signals to each other and work carefully for safety's sake.

(1) Lower the bucket on the ground as the picture shown in the right.

(2) Lock the safety lever to the LOCK position and stop the engine.

(3) Remove the stopper bolts(1) and nuts(2), then remove pins(3, 4) and remove the bucket.

When removing the pins, place the bucket so that it is in light contact with the ground.

If the bucket is lowered strongly to the ground, the resistance will be increased and it will be difficult to remove the pins.

After remove the pins, make sure that they do not become contaminated with sand or mud and that the seals of bushing on both sides do not become damaged.

(4) Align the arm with holes(A) and the link with holes(B), then coat with grease and install pins(3, 4)

When installing the bucket, the O-rings are easily damaged, so fit the O-rings on the boss of the bucket as shown in the picture.

After knocking the pin, move the O-ring down to the regular groove.

(5) Install the stopper bolt(1) and nuts(2) for each pin, then grease the pin.

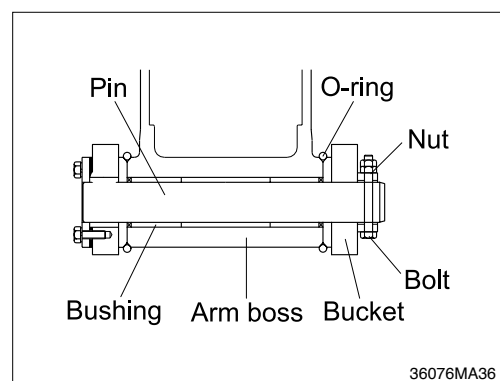
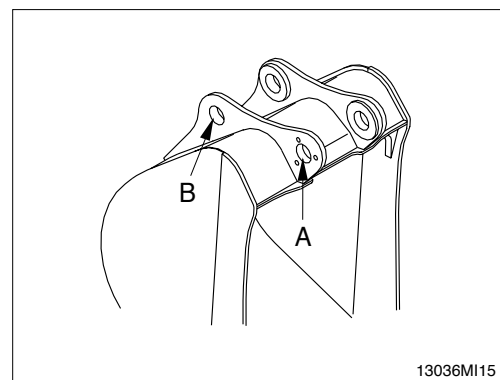
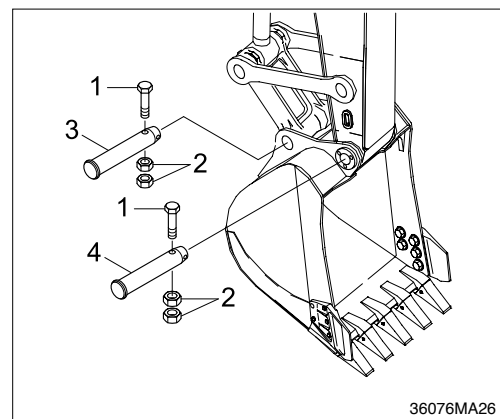
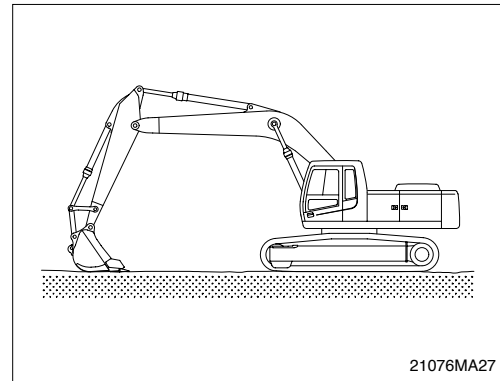

34) REPLACEMENT OF BUCKET TOOTH

(1) Timing of replacement

Check wearing condition as shown in the illustration and replace tooth tip before adapter starts to wear.

If excessive use, tooth adapter has worn out, replacement may become impossible.

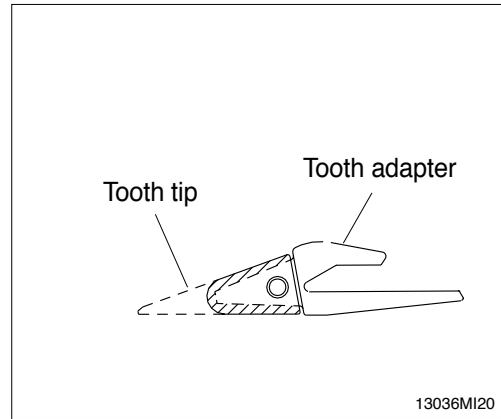

(2) Instructions for replacement

Pull out pin by striking pin with punch or hammer, avoiding damage to locking washer.

Remove dust and mud from surface of tooth adapter by using knife.

Place locking washer in its proper place, and fit tooth tip to adapter.

Insert pin until locking washer is positioned at tooth pin groove.

▲ Personal injury can result from bucket falling.

▲ Block the bucket before changing tooth tips or side cutters.

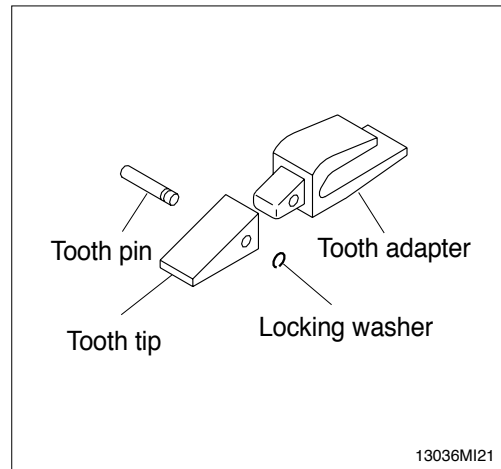

35) ADJUSTMENT OF BUCKET CLEARANCE

- (1) Lower the bucket on the ground as the picture shown in the right.
- (2) Swing to the right and keep the arm boss to be contact to the bucket right.
- (3) Lock the safety lever to the LOCK position and stop the engine.
- (4) Measure the clearance(A) between bucket and arm boss. This is the total clearance.

(5) Adjusting

Loosen bolt(2), and remove washer(3), plate(1) and shim(4).

Remove the shim equivalent value with measuring value.

Assemble the parts in the reverse order of removal.

- Tightening torque : $29.6 \pm 3.2 \text{kgf} \cdot \text{m}$
($214.0 \pm 23.1 \text{lbf} \cdot \text{ft}$)
- Normal clearance : $0.5 \sim 1.0 \text{mm}$
($0.02 \sim 0.04 \text{in}$)

If the bucket is not adjusted correctly, noise and vibration created during operation, and damaged O-ring, pin and bushing quickly.

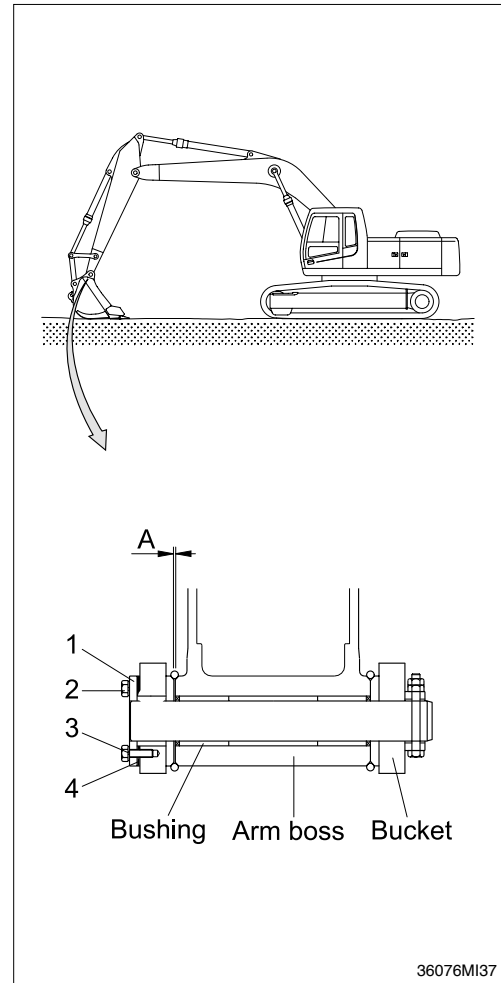

36) LUBRICATE PIN AND BUSHING

(1) Lubricate to each pin of working device

Lubricate the grease to the grease nipple according to the lubricating interval.

No.	Description	Qty
1	Lubrication manifold at boom	5
2	Boom cylinder pin	2
3	Boom and arm connection pin	1
4	Arm cylinder pin(Rod side)	1
5	Bucket cylinder pin(Head, rod)	2
	Bucket link(Control rod)	3
	Arm and bucket connection pin	1
	Arm and control link connection pin	1

Shorten lubricating interval when working in the water or dusty place.

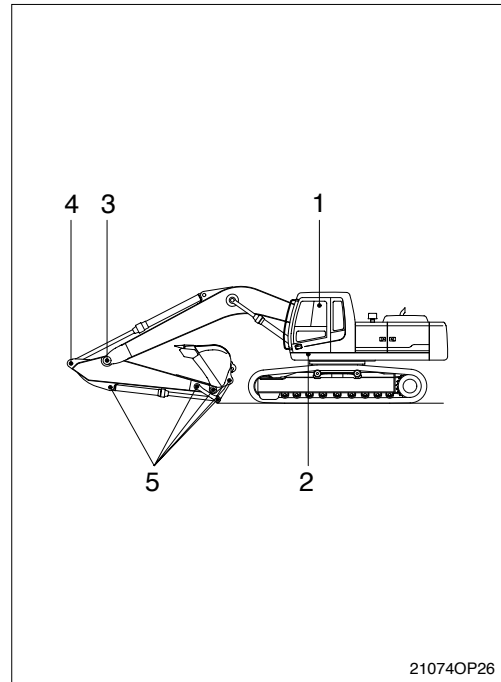

(2) Dust seals are mounted on the rotating part of working device to extend the lubricating interval.

Mount the lip to be faced outside when replace the dust seal.

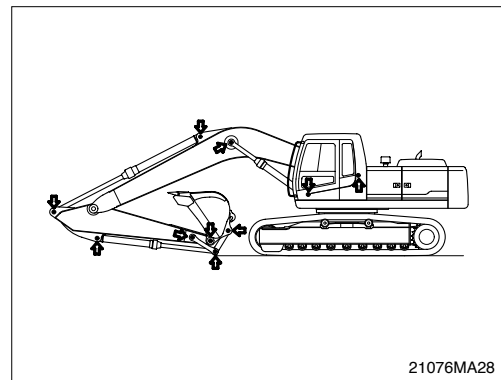

If it is assembled in wrong direction, it will cause fast wear of pin and bushing, and create noise and vibration during operation. Assemble the seal same direction with picture and use with plastic hammer when replace.

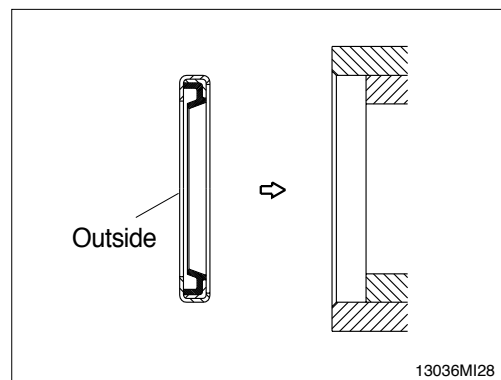

7. ELECTRICAL SYSTEM

1) WIRING, GAUGES

Check regularly and repair loose or malfunctioning gauges when found.

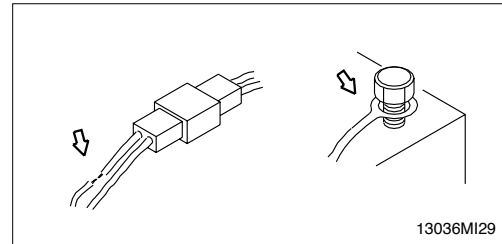

2) BATTERY

(1) Check and repair

Check the electrolyte level and fill with distilled water to the prescribed level as necessary.

Wash the terminal with hot water if it is contaminated, and apply grease to the terminals after washing.

▲ Do not stain clothes or skin with electrolyte as it is acid.

Be careful not to get the electrolyte in eyes.

Wash with clean water and go to the doctor if it enters the eyes.

Remove the fire and spark around battery.

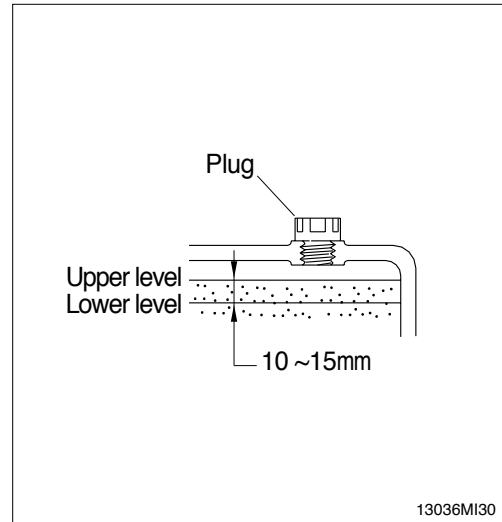

(2) Specific gravity of battery

Judge the charging rate of battery by the specific gravity. The specific gravity changes by the ambient temperature.

Check the charging rate by referring to the chart below.

Temperature Charging rate	20.°C (68.°F)	10.°C (50.°F)	-10.°C (14.°F)
	100%	1.26	1.27
90%	1.24	1.25	1.26
80%	1.22	1.23	1.24
75%	1.21	1.22	1.23

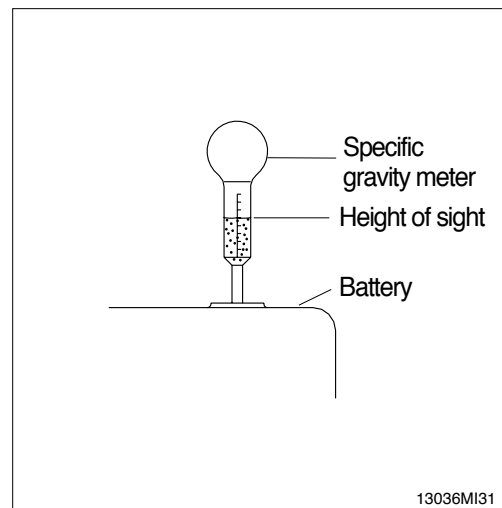

(3) Method of removing the battery cable

Remove the cable from the ground connection first (⊖ terminal side) and reconnect it last when reassembling.

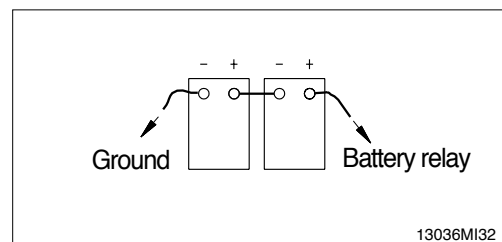

3) STARTING THE ENGINE WITH A BOOSTER CABLE

Keep following order when you are going to start engine using booster cable.

(1) Connection of booster cable

Use the same capacity of battery for starting.

Make sure that the starting switches of the normal machine and trouble machine are both at the OFF position.

Connect the red terminal of booster cable to the battery (+) terminal between exhausted and new battery.

Connect the black terminal of the booster cable between new battery (-) terminal and chassis of trouble machine.

Keep firmly all connection, the spark will be caused when connecting finally.

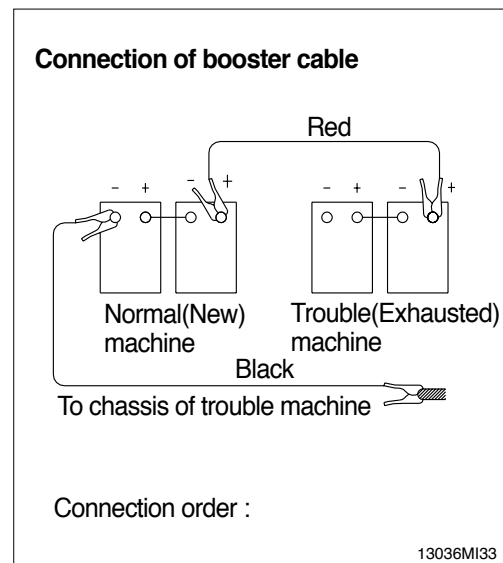

(2) Starting the engine

Starting the engine of the normal machine and keep it to run at high idle.

Start engine of the trouble machine with starting switch.

If you can not start it by one time, restart the engine after 2 minutes.

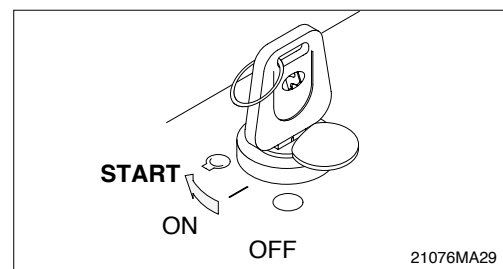

(3) Taking off the booster cable

Take off the booster cable(black).

Take off the booster cable(red) connected to the (+) terminal.

Run engine with high idle until charging the exhausted battery by alternator, fully.

▲ Explosive gas is generated while using the battery or charging it. Keep away flame and be careful not to cause the spark.

Charge the battery in the well ventilated place.

Place the machine on the earth or concrete.

Avoid charging the machine on the steel plate.

Do not connect (+) terminal and (-) terminal when connecting booster cable because it will be shorted.

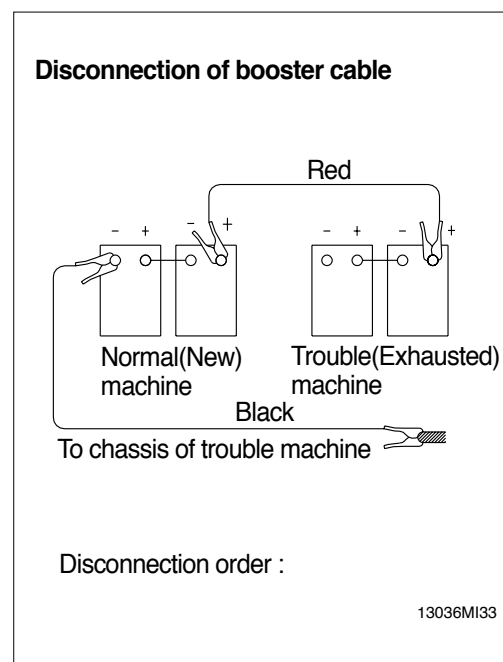

(4) Welding repair

Before start to welding, follow the below procedure.

- ① Shut off the engine and remove the starting switch.
 - ② Disconnect ground cable from battery by master switch.
 - ③ Before carrying out any electric welding on the machine, the battery cables should be disconnected and the connectors pulled out of the electronic control units(ECM, CPU, cluster etc).
 - ④ Connect the earth(ground) lead of the welding equipment as close to the welding point as possible.
- ※ Do not weld or flame cut on pipes or tubes that contain flammable fluids. Clean them thoroughly with nonflammable solvent before welding or flame cutting on them.
- ▲ Do not attempt to welding work before carry out the above.

If not, it will caused serious damage at electric CAPO system.

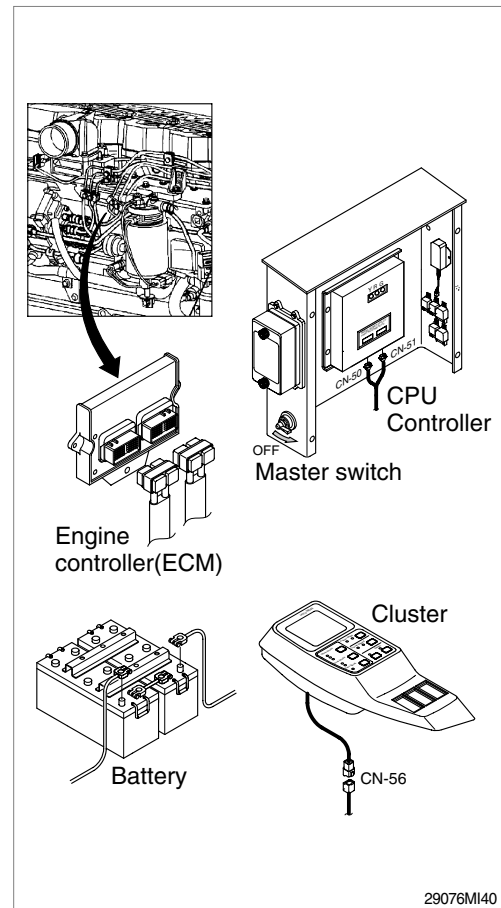

8. AIR CONDITIONER AND HEATER

1) CLEAN AND REPLACE OF FRESH AIR FILTER

Always stop the engine before servicing.

- (1) Move seat and console box to arrow direction using the adjust lever.

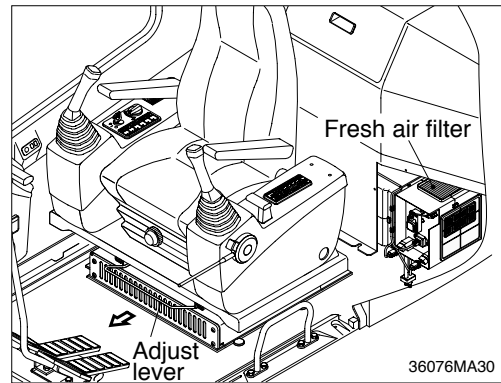

- (2) Remove the outer filter.

When installing a filter, be careful not to change the filter direction.

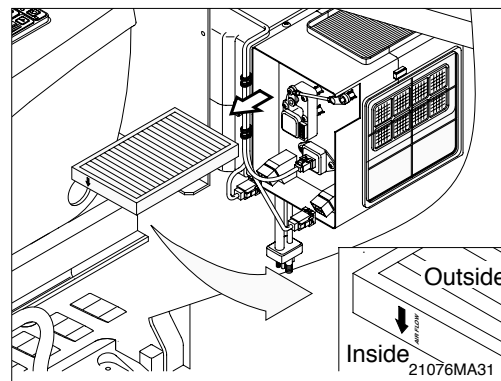

- (3) Clean the filter using a pressurized air (Below 2kgf/cm^2 , 28psi).

△ **When using pressurized air, be sure to wear safety glasses.**

- (4) Inspect the filter after cleaning. If it is damaged or badly contaminated, use a new filter.

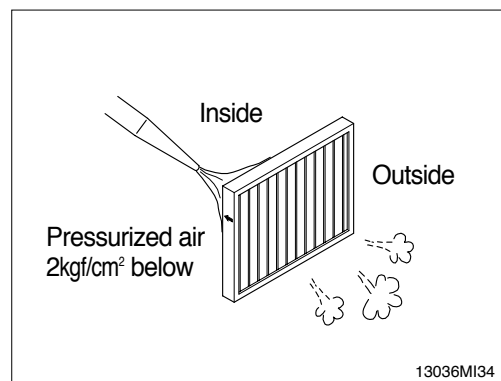

2) CLEAN AND REPLACE OF RECIRCULATION FILTER

Always stop the engine before servicing.

- (1) Move seat and console box to arrow direction using the adjust lever.

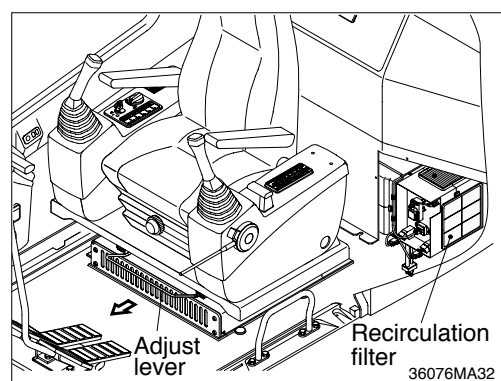

(2) Remove recirculation filter.

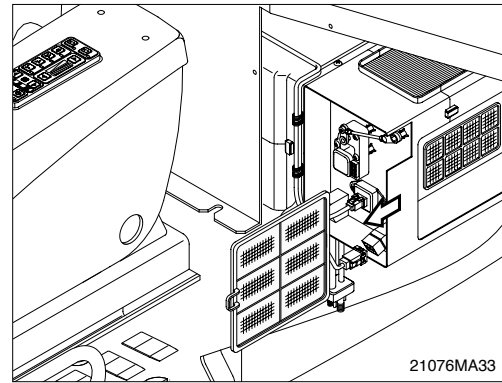

(3) Clean the recirculation filter using a pressurized air (Below 2kgf/cm^2 , 28psi) or washing with water.

△ **When using pressurized air, be sure to wear safety glasses.**

Dry off after washing with water.

(4) Inspect the filter after cleaning. If it is damaged or badly contaminated, use a new filter.

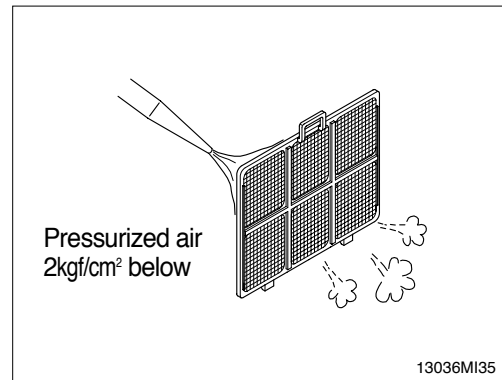

3) PRECAUTIONS FOR USING AIR CONDITIONER

(1) When using the air conditioner for a long time, open the window once every one hour.

(2) Be careful not to overcool the cab.

(3) The cab is properly cooled if the operator feels cool when entering there from outside (About 5°C lower than the outside temperature).

(4) When cooling, change air occasionally.

4) CHECK DURING SEASON

Ask the service center for replenishment of refrigerant or other maintenance service so that the cooling performance is not damaged.

5) CHECK DURING OFF-SEASON

Operate the air conditioner 2 or 3 times a month (Each for a few minutes) to avoid loss of oil film in the compressor.