

## 5. MAINTENANCE CHART

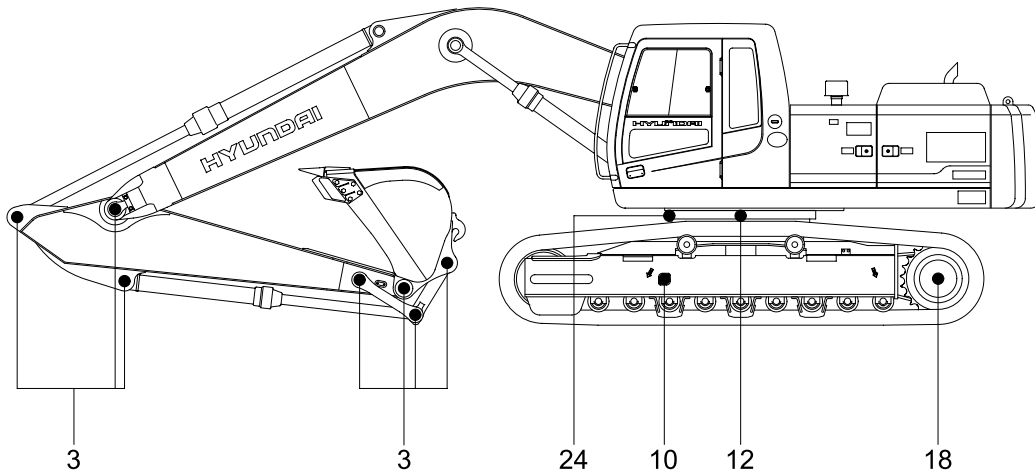
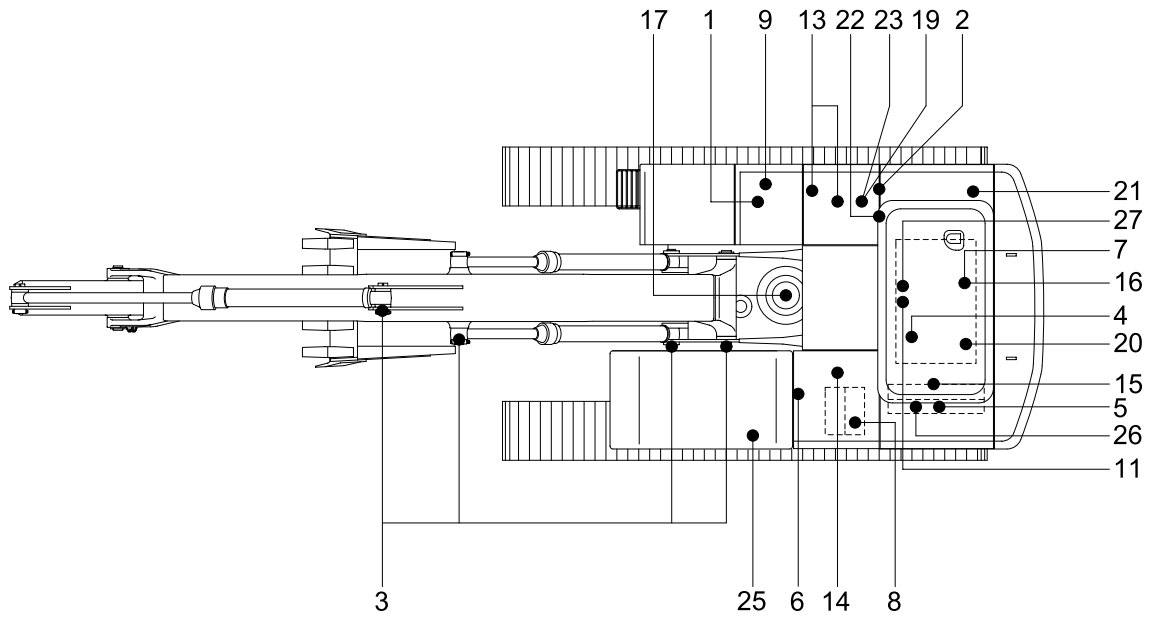

36076MI05

### Caution

1. Service intervals are based on the hour meter reading.
2. The number of each item shows the lubrication point on the machine.
3. Stop engine while filling oil, and use no open flames.
4. For other details, refer to the service manual.

Service interval	No.	Description	Service action	Oil symbol	Capacity l (U.S.gal)	Service points No.
10 Hours or daily	1	Fuel tank	Check, Refill	DF	520(137)	1
	2	Hydraulic oil level	Check, Add	HO	230(61)	1
	4	Engine oil level	Check, Add	EO	26.5(7.0)	1
	5	Radiator coolant	Check, Add	C	45(12)	1
	6	Control panel & pilot lamp	Check, Clean	-	-	1
	7	Water separator	Check, Drain	-	-	1
50 Hours or weekly	3	Attachment pins	Check, Add	PGL	-	17
	9	Fuel tank strainer and drain	Check, Clean	-	-	1
	10	Track tension	Check, Adjust	PGL	-	2
	12	Swing bearing grease	Check, Add	PGL	-	3
	17	Swing drive gear case	Check, Add	GO	6(1.6)	1
250 Hours	8	Battery(Electrolyte)	Check, Add	-	-	2
	13	Hydraulic oil return filter	Replace	-	-	1
	21	Line filter element	Replace	-	-	1
	22	Drain filter cartridge	Replace	-	-	2
	23	Air breather element	Replace	-	-	1
	26	Charge air cooler	Check, Replace	-	-	1
500 Hours	4	Engine oil level	Change	EO	26.5(7.0)	1
	11	Engine oil filter	Replace	-	-	1
	14	Air cleaner element	Clean	-	-	2
	15	Radiator and cooler fin	Check, Clean	-	-	1
	16	Fuel filter element	Replace	-	-	2
	18	Final drive gear case	Check, Add	GO	7(1.8)	2
	27	Corrosion resistor	Replace	-	-	1
1000 Hours	17	Swing drive gear case	Change	GO	6(1.6)	1
	18	Final drive gear case	Change	GO	7(1.8)	2
	20	Fan belt tensioner, auto adjustable	Check, Replace	-	-	1
	24	Swing gear and pinion	Change	PGL	12.8(3.4)	1
2000 Hours	2	Hydraulic oil level	Change	HO	230(61)	1
	5	Radiator coolant	Change	C	45(12)	1
	19	Hydraulic oil suction strainer	Check, Clean	-	-	1
As required	25	Air conditioner filters	Check, Clean	-	-	2

※ **Oil symbol**

Please refer to the recommended lubricants for specification.

DF : Diesel fuel

GO : Gear oil

HO : Hydraulic oil

C : Coolant

PGL : Grease

EO : Engine oil