

SPECIFICATIONS

1. MAJOR COMPONENT

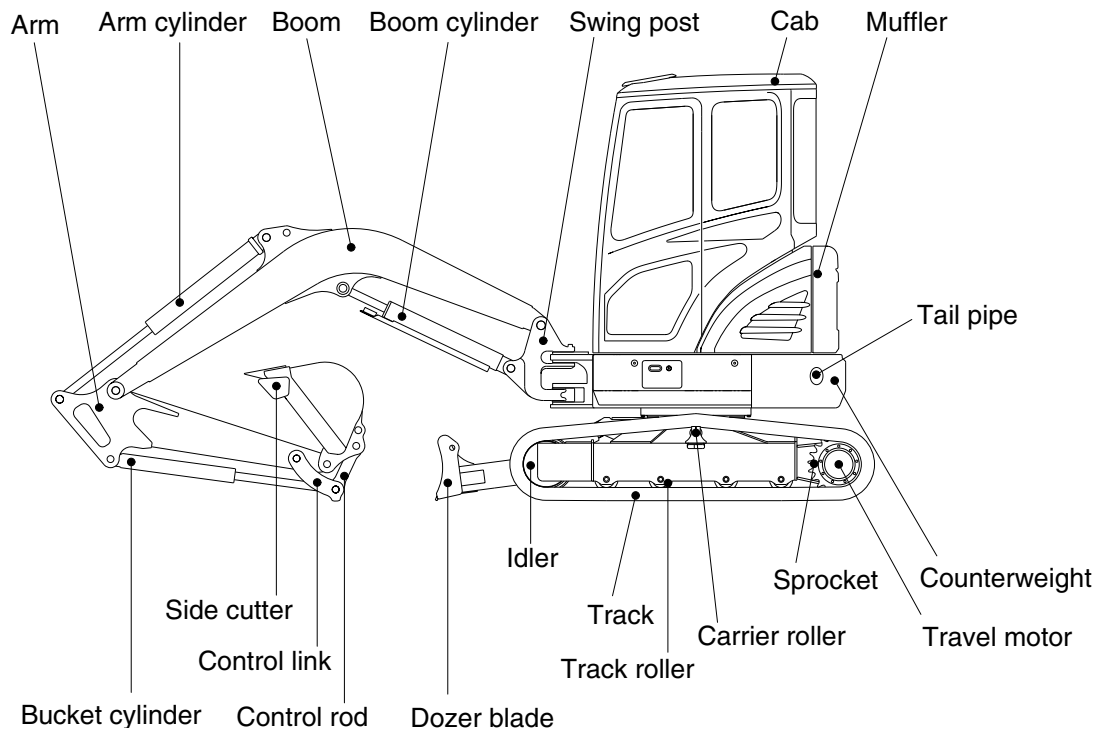
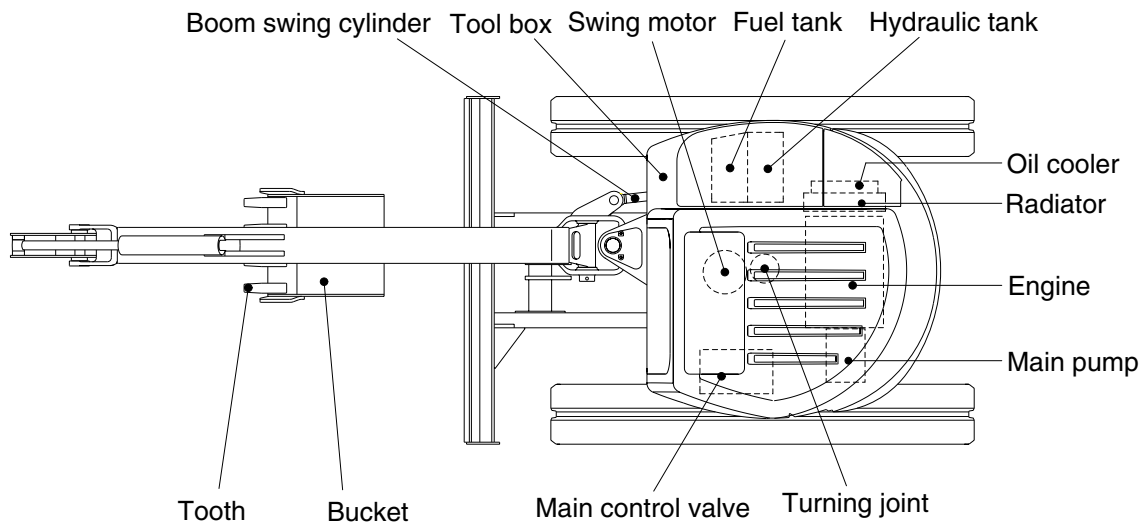

R35Z72SP01