

SPECIFICATIONS

1. MAJOR COMPONENT

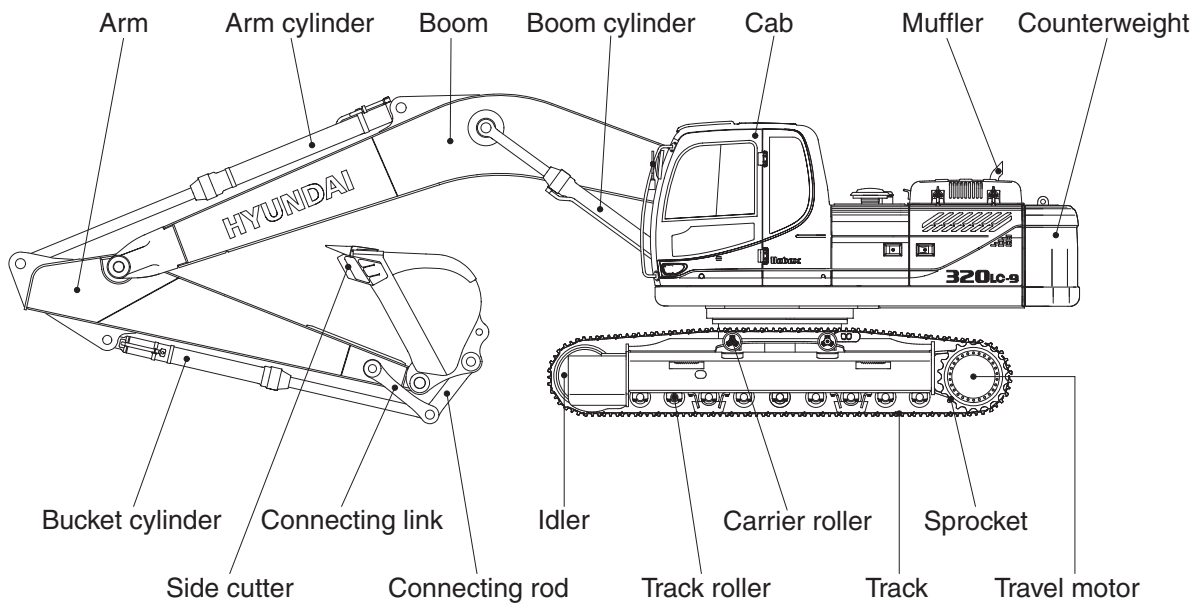
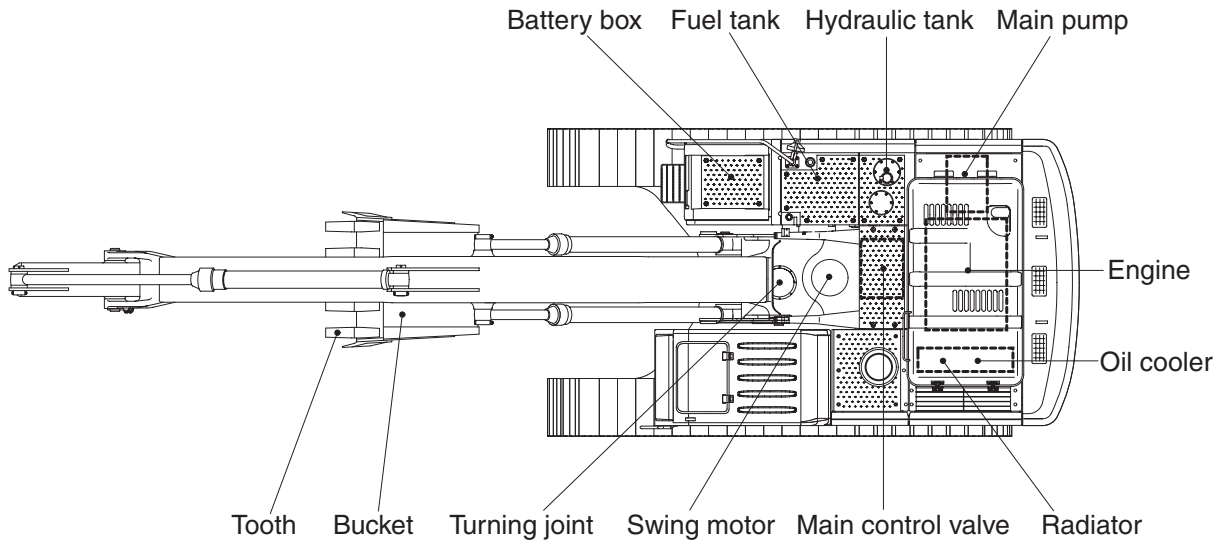

32092SP01A