

1. SUGGESTION FOR NEW MACHINE

- 1) It takes about 100 operation hours to enhance its designed performance.
- 2) Operate according to below three steps and avoid excessive operation for the initial 100 hours.

Service meter	Load
Until 10 hours	About 60%
Until 100 hours	About 80%
After 100 hours	100%

※ **Excessive operation may deteriorate the potential performance of machine and shorten lifetime of the machine.**

3) Be careful during the initial 100 hours operation

- (1) Check daily for the level and leakage of coolant, engine oil, hydraulic oil and fuel.
- (2) Check regularly the lubrication and fill grease daily all lubrication points.
- (3) Tighten bolts.
- (4) Warm up the machine fully before operation.
- (5) Check the gauges occasionally during the operation.
- (6) Check if the machine is operating normally during operation.

4) Replace followings after initial 50 hours of operation

Checking items	Service
Engine oil	Replace
Engine oil filter element	
Hydraulic oil return filter element	
Hydraulic oil tank drain filter cartridge	
Line filter element	
Fuel filter	

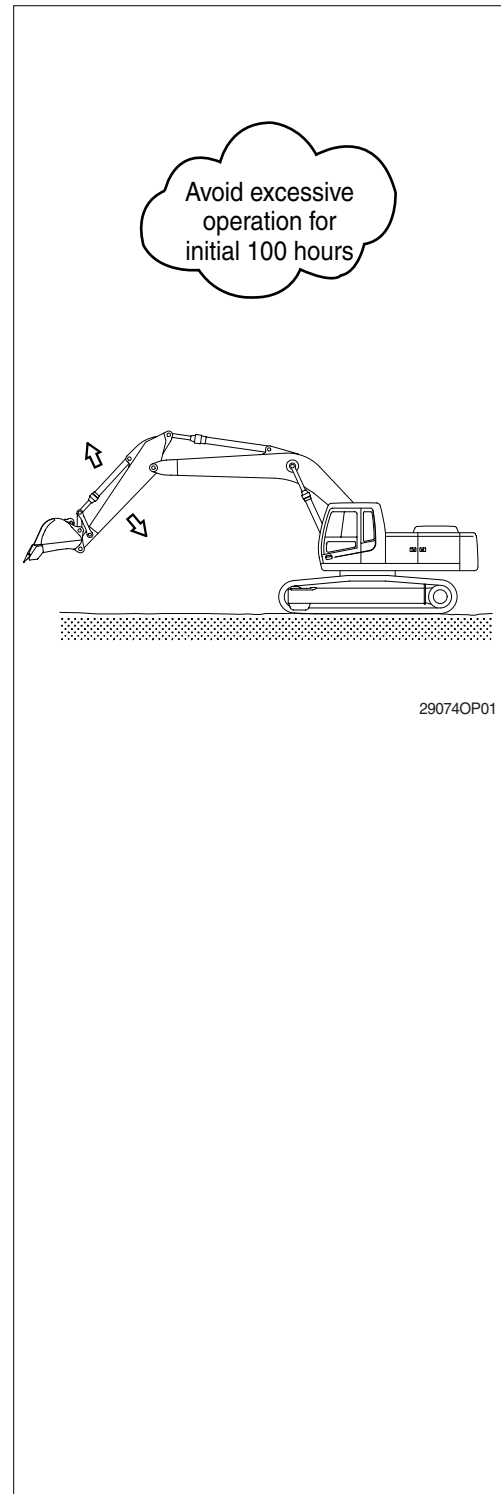

2. CHECK BEFORE STARTING THE ENGINE

- 1) Look around the machine and under the machine to check for loosen nut or bolts, collection of dirt, or leakage of oil, fuel or coolant and check the condition of the work equipment and hydraulic system. Check also loosen wiring, and collection of dust at places which reach high temperature.
※ **Refer to the daily check on the chapter 6, maintenance.**
- 2) Adjust seat to fit the contours of the operator's body for the pleasant operation.
- 3) Adjust the rear view mirror.

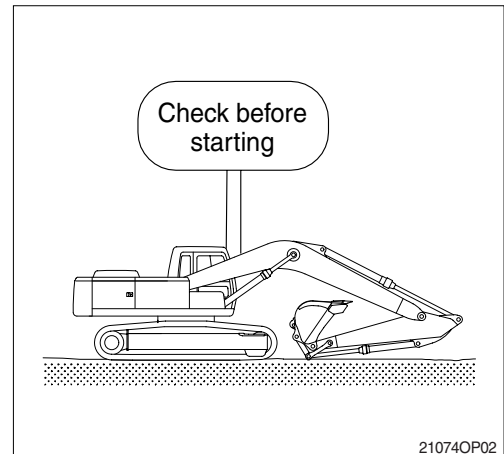

3. STARTING AND STOP THE ENGINE

1) CHECK INDICATOR LIGHTS

- (1) Check if all the operating lever is on the neutral position.
- (2) Turn the starting switch to the ON position, and check following.
 - ① If all the lamps light ON and buzzer sounding for 2 seconds.
 - ② After lamp check **CL : 2.0**, the version of cluster program, is displayed on **Monitoring display(3)** for 5 seconds and the cluster returns to default.
 - ③ Only below lamps will light ON and all the other lights will turn OFF after 2 seconds.
 - Engine oil pressure warning lamp(1)
 - Battery charging warning lamp(2)

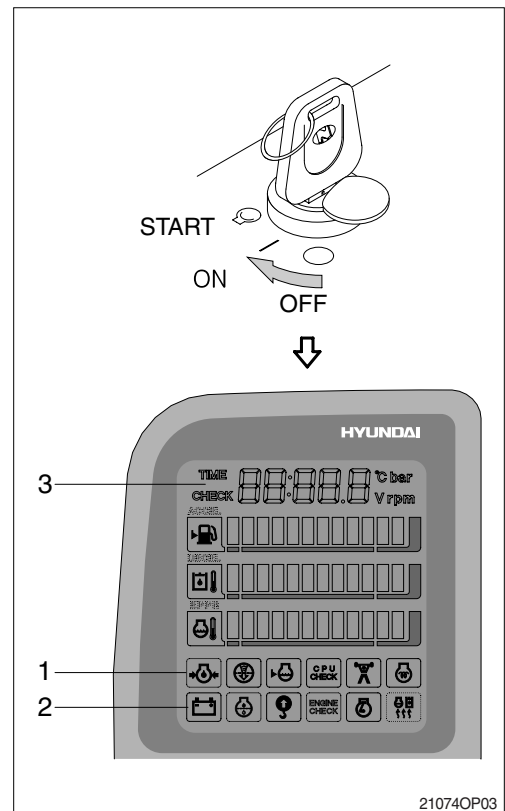

2) STARTING ENGINE IN NORMAL TEMPERATURE

※ Sound the horn to warn the surroundings after checking if personnel or obstacles are in the area.

- (1) Turn the starting switch to START position to start the engine.
 - ※ If the engine does not start, allow the starter to cool for about 2 minutes before attempting to start the engine again.
- (2) Release the starting switch instantly after the engine starts to avoid possible damage to the starting motor.

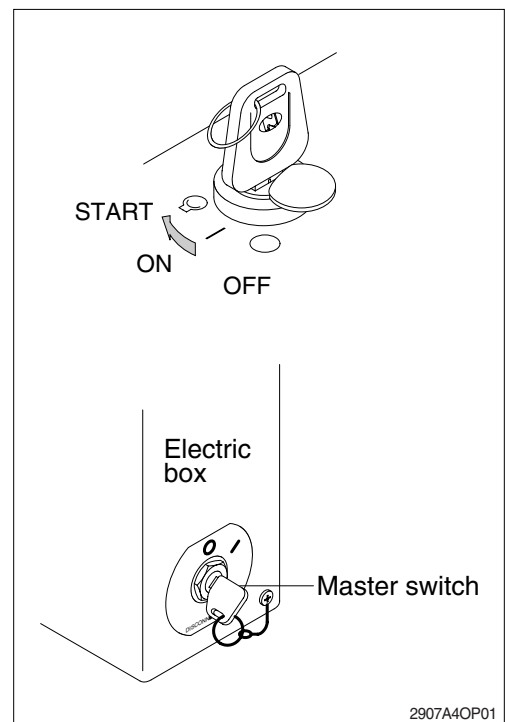

3) STARTING ENGINE IN COLD WEATHER

- ※ Sound horn to warn surroundings after checking if there are obstacles in the area.
- ※ Replace the engine oil and fuel referring to recommended oils at page 2-30.
- ※ Fill the anti-freeze solution to the coolant as required.

- (1) Check if all the levers are in the neutral position.
- (2) Turn the starting switch to ON position, and wait the preheat pilot lamp OFF.
- (3) Start the engine by turning the starting switch to the START position after the preheat pilot lamp OFF.
 - ※ If necessary use the preheat switch.
 - ※ If the engine does not start, allow the starter to cool for about 2 minutes before attempting to start the engine again.
- (4) Release the starting switch immediately after starting engine.
- (5) The operation for the warming up machine is automatic.

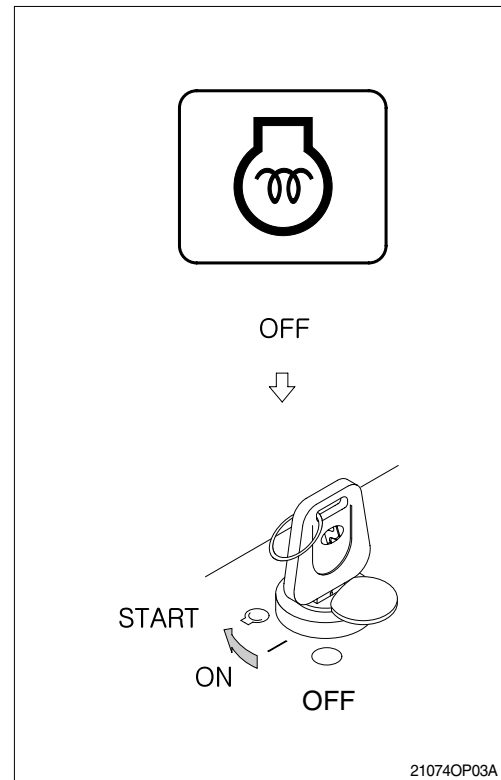

4) INSPECTION AFTER ENGINE START

Inspect and confirm the following after engine starts.

- (1) Is the level gauge of hydraulic oil tank in the normal level?
- (2) Are there leakages of oil or water?
- (3) Are all the warning lamps OFF(1-8)?
- (4) Is the indicator of engine coolant temperature gauge(9) and hydraulic oil temperature gauge(10) in the green zone?
- (5) Is the engine sound and the color of exhaust gas normal?
- (6) Are the sound and vibration normal?
 - ※ Do not increase engine speed quickly after starting, it can damage engine or turbocharger.
 - ※ If there are problems in the control panel, stop the engine immediately and correct problem as required.

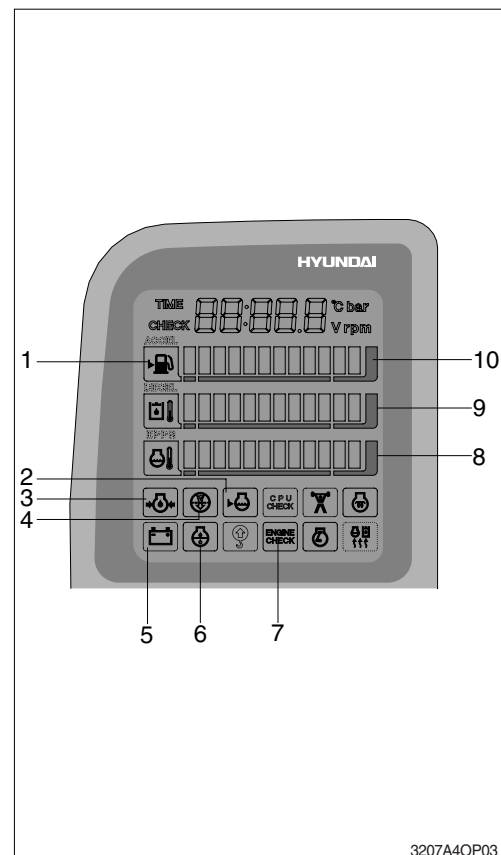

5) WARMING-UP OPERATION

- ※ The most suitable temperature for the hydraulic oil is about 50°C (122° F).

It can cause serious trouble in the hydraulic system by sudden operation when the hydraulic oil temperature is below 25°C (77° F).

Then temperature must be raised to at least 25°C (77° F) before starting work.

- (1) Run the engine at low idling for 5 minutes.
- (2) Speed up the idling and run the engine at mid-range speed.
- (3) Operate bucket lever for 5 minutes.
 - ※ **Do not operate anything except bucket lever.**
- (4) Run the engine at the high speed and operate the bucket lever and arm lever for 5-10 minutes.
 - ※ **Operate only the bucket lever and arm lever.**
- (5) This warming-up operation will be completed by operation of all cylinders several times, and operation of swing and traveling.
 - ※ **Increase the warming-up operation during winter.**

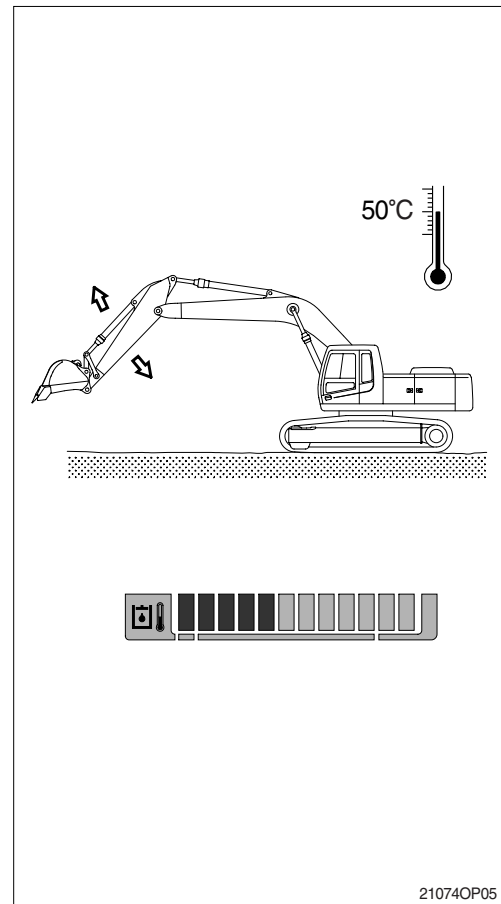

6) TO STOP THE ENGINE

- ※ If the engine is abruptly stopped before it has cooled down, engine life may be greatly shortened. Consequently, do not abruptly stop the engine apart from an emergency.
- ※ In particular if the engine has overheated, do not abruptly stop it but run it at medium speed to allow it to cool gradually, then stop it.

- (1) Down the bucket on the ground then put all the levers in the neutral position.
- (2) Run the engine at low idling speed for about 5 minutes.
- (3) Return the key of starting switch to the OFF position.
- (4) Remove the key to prevent other people using the machine and LOCK safety lever.
- (5) Lock the cab door.

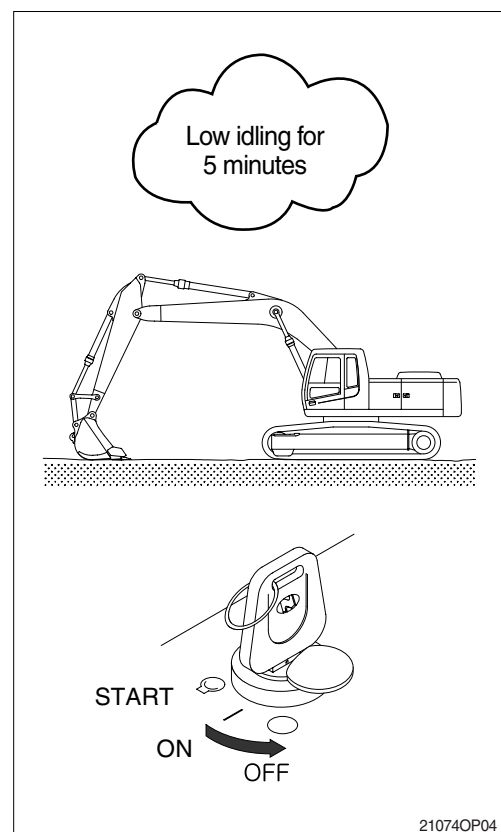

4. MODE SELECTION SYSTEM

1) STRUCTURE OF CAPO SYSTEM

CAPO, Computer Aided Power Optimization system, is the name of mode selection system developed by Hyundai.

(1) Work mode

3 work modes can be selected for the optimal work speed of the machine operation.

① Heavy duty work mode

The boom priority solenoid is activated to make the boom operation speed faster.

② General work mode

When key switch is turned ON, this mode is selected automatically and swing operation speed is faster than heavy duty work mode.

③ Breaker operation mode

It sets the pump flow to the optimal operation of breaker by activating the max flow cut-off solenoid.

(2) Power mode

Power mode designed for various work loads maintains high performance and reduces fuel consumption.

- H mode : High power
- S mode : Standard power

(3) User mode

- M : Maximum power
- U : You can change the engine and pump power and memorize it for your preference.

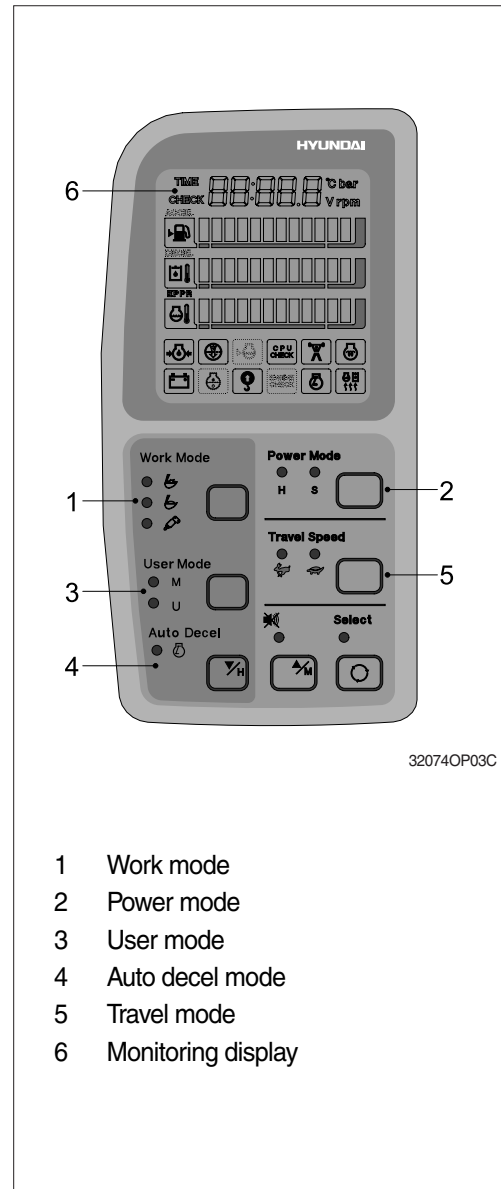

- 1 Work mode
- 2 Power mode
- 3 User mode
- 4 Auto decel mode
- 5 Travel mode
- 6 Monitoring display

How to modulate the memory set

- ① Each memory mode has a initial set which are mid-range of max engine speed, auto decel rpm, and EPPR valve input current. When you select U, cluster LCD displays.

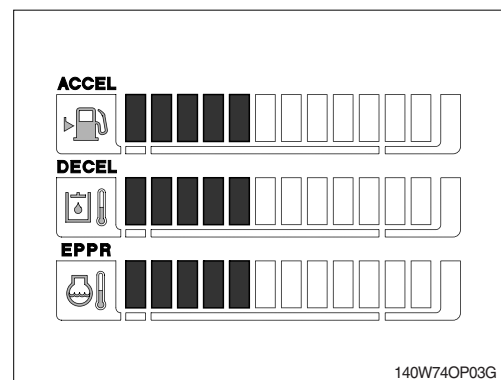

- ② To change the engine high idle speed, press the USER mode switch and SELECT switch at the same time and then ACCEL blinks at 0.5 seconds interval.
- By pressing ▲ or ▼ switch, █ will increase or decrease.
- ③ To change DECEL rpm, press the USER mode switch and SELECT switch once more and then DECEL blinks at 0.5 seconds interval.
- By pressing ▲ or ▼ switch, █ will increase or decrease.
- ④ To change EPPR current, press the USER mode switch and SELECT switch once more and then EPPR blinks at 0.5 seconds interval.
- By pressing ▲ or ▼ switch, █ will increase or decrease.

• LCD segment vs parameter setting



Segment (█)	ACCEL (rpm)	DECEL (rpm)	EPPR (mA)
1	1350	One touch decel Low idle(700)	150
2	1400	750	200
3	1450	800	250
4	1500	850	300
5	1550	900	350
6	1600	950	400
7	1650	Auto decel rpm(1000)	450
8	1700	1050	500
9	1750	1100	550
10	1800	1150	600

- ⑤ To memorize the final setting, press the USER mode switch and SELECT switch one more time.

(4) Auto decel mode

Engine quick deceleration.

(5) Travel mode

-  : Low speed traveling.
-  : High speed traveling.

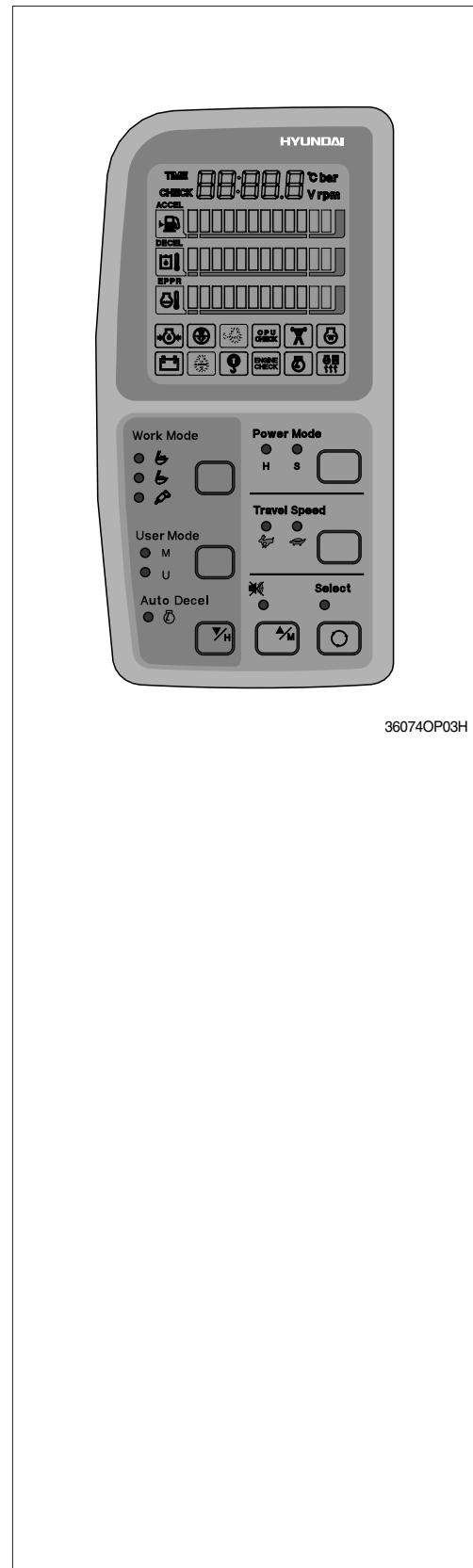

36074OP03H

(6) Monitoring system

Information of machine performance as monitored by the CPU controller can be displayed on the **monitoring display**.

※ Refer to 4-11 page for details.

(7) Self diagnostic system

① CPU controller

The CPU controller diagnoses problems in the CAPO system caused by electric parts' malfunction and by open or short circuit, which are displayed on the **monitoring display** as error codes(2digit).

※ Consult hyundai or hyundai dealer for details.

② Engine controller(ECM)

If the engine or relevant system has problem ECM diagnoses and displays on the monitoring display as fault codes(3 digit).

※ Consult hyundai or hyundai dealer for details.

(8) Anti-restart system

The system protects the starter from inadvertent restarting after the engine is already operational.

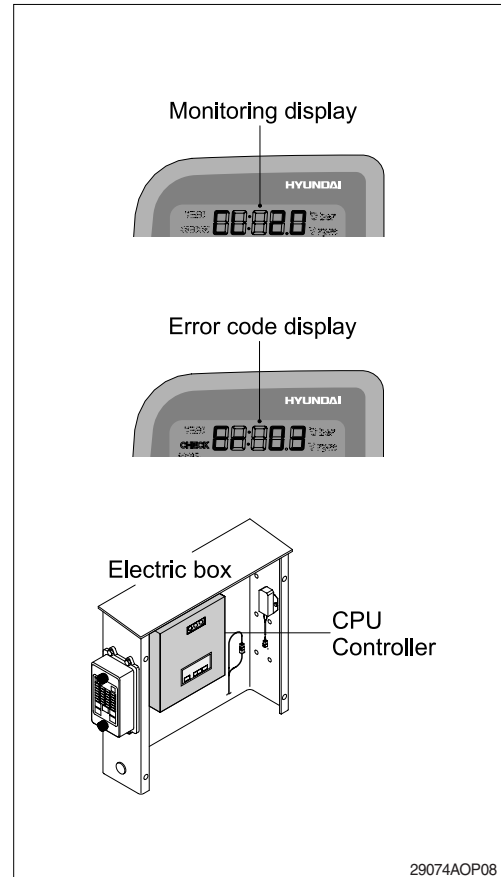

2) HOW TO OPERATE MODE SELECTION SYSTEM

(1) When start key is turned ON

① When start key is turned ON, all illumination lamps are ON and all lamps are OFF automatically after 5 seconds. But a battery charging warning lamp and an engine oil pressure warning lamp keep turned ON until engine starting.

② After lamp check 「CL : 2.0」, the version of cluster program, is displayed on **Monitoring display** for 2 seconds.

③ After the version of program is displayed, the cluster returns to default. Exactly engine rpm, battery charging warning lamp and engine oil pressure warning lamp are turned ON and S mode, auto decel, low travel speed(Turtle mark) are displayed.

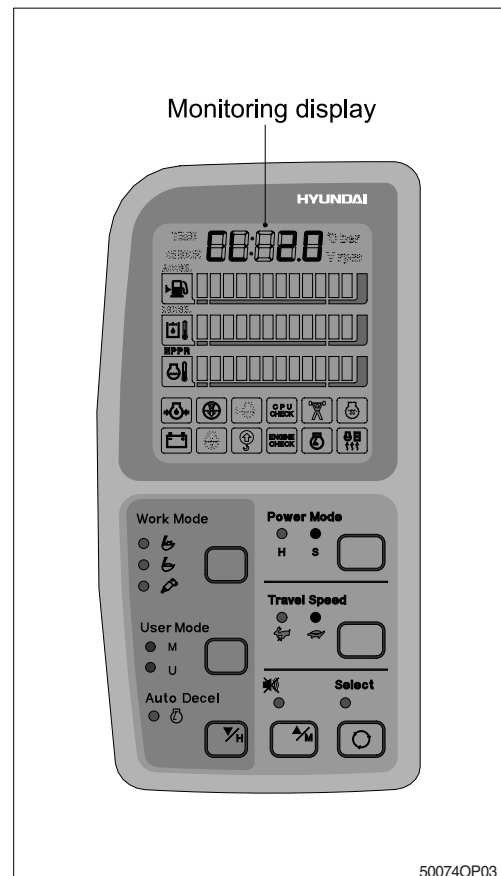

④ In default condition self-diagnostic function including trouble detecting of electric system can be carried out.

※ Refer to 4-11 page for details.



(2) After engine start

- ① When the engine is started, three lamps are ON as below.

Mode		Status
Work mode		ON
Power mode	S	ON
Travel mode	Low()	ON
Auto decel mode		ON

- In this condition, tachometer indicates low idle, 700 ± 100 rpm.
- If coolant temperature is below 30°C , after 10 seconds the engine speed increases to 1000 ± 100 rpm automatically to warm up the machine.
- After 2-3 minutes, you can select any mode depending on job requirement.

- ② Self-diagnostic function can be carried out the same as start key is ON.

※ Refer to 4-11 page for details.

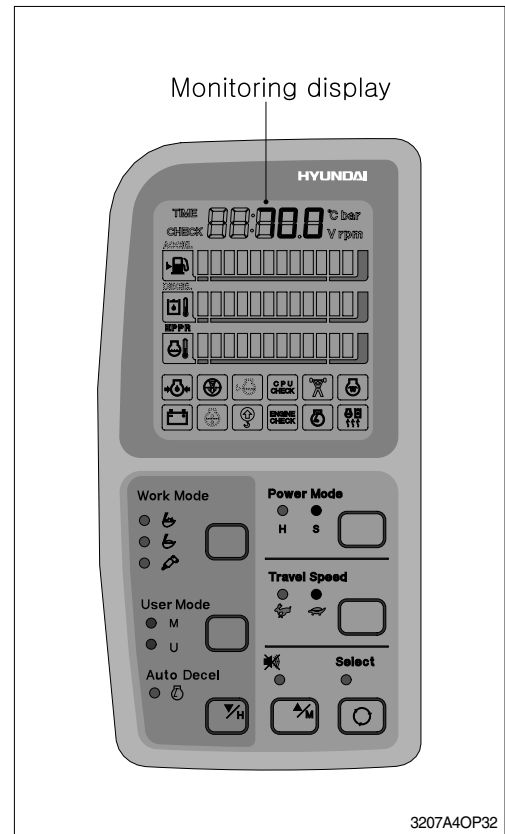

3) SELECTION OF POWER MODE

(1) S mode

When the accel dial is at setting 10 and auto decel mode is cancelled and S mode is selected.

Engine rpm	Effect
1600 ± 50	Same power as non mode type machine.

- ※ When the accel dial is located below 9 the engine speed decreases about 50~100rpm per dial set.

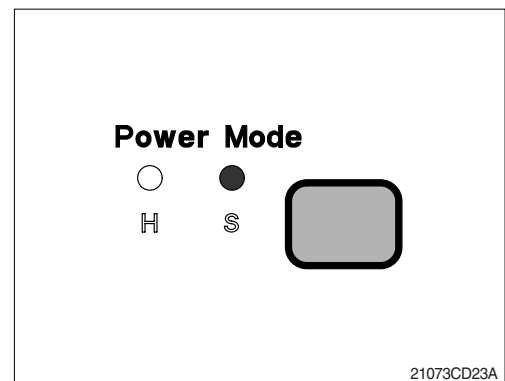

(2) H mode

When the accel dial is at setting 10 and auto decel mode is cancelled and H mode is selected.

Engine rpm	Effect
1700 ± 50	Approximately 110% of power and speed available than non mode type machine or S mode.

- ※ When the accel dial is located below 9 the engine speed decreases about 50~100rpm per dial set.

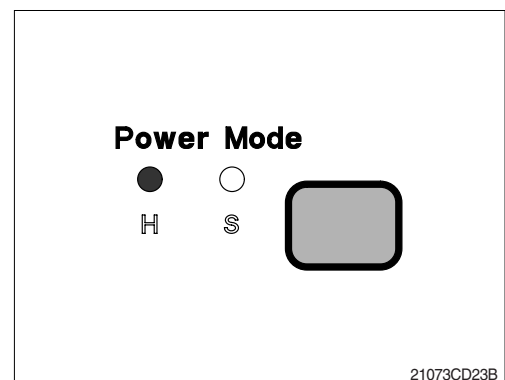

(3) M mode

When the accel dial is at setting 10 and auto decel mode is cancelled and H mode is selected.

Engine rpm	Effect
1800 ± 50	Approximately 130% of power and speed available than non mode type machine or S mode.

※ When the accel dial is located below 9 the engine speed decreases about 50~100rpm per dial set.

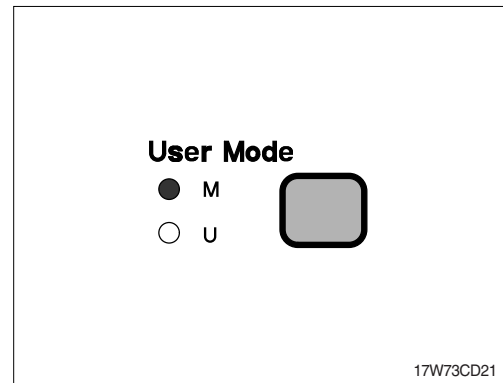

4) MONITORING DISPLAY

Information of machine performance as monitored by the CPU controller can be displayed on the cluster when the operator selects a display mode by touching **SELECT** switch alone or with **BUZZER STOP** switch on the cluster as below.

Display group	How to select display mode		Name	Display on the cluster	
	Group selection	Display mode selection			
Group 0 (Default)	Way 1 Key switch ON or START Way 2 Touch AUTO DECEL switch while pressing BUZZER STOP at group 1~4.	Initial	Engine rpm	700 rpm	
		Touch SELECT 1 time	Time	TIME 12:30	
		Touch SELECT 2 times	Power shift pressure (EPPR valve)	EP: 10 bar	
		Touch SELECT 3 times	CPU model & version	32C5.1	
		Touch SELECT 4 times	Option (Only when a pressure sensor is installed)	Front pump pressure	P1: 100 bar
		Touch SELECT 5 times		Rear pump pressure	P2: 200 bar
		Touch SELECT 6 times		Pilot pressure	P3: 30 bar
Group 1 (Volt, temp, EPPR press, version)	Touch SELECT switch once while pressing BUZZER STOP . In this group SELECT LED ON	Default	Battery voltage(V)	b: 24.8 v	
		Touch SELECT 1 time	Potentiometer voltage(V)	Pa: 2.5 v	
		Touch SELECT 2 times	Accel dial voltage(V)	dL: 3.8 v	
		Touch SELECT 3 times	Hydraulic oil temperature(°C)	Hd: 50 °C	
		Touch SELECT 4 times	Coolant temperature(°C)	Ct: 85 °C	
		Touch SELECT 5 times	Ambient pressure(KPA)	AP: 100	
Group 2 (Error code)	Touch SELECT switch twice while pressing BUZZER STOP . In this group BUZZER STOP LED blinks	Default	Current error	CHECK Er: 03	
		Touch SELECT 1 time	Recorded error (Only key switch ON)	TIME Er: 03	
		Press down(▼) & SELECT at the same time	Recorded error deletion (Only key switch ON)	TIME Er: 00	
Group 3 (Switch input)	Touch SELECT switch 3 times while pressing BUZZER STOP . In this group SELECT LED blinks at 0.5sec interval	Default	Pump prolix switch	PP: on or off	
		Touch SELECT 1 time	Auto decel pressure switch	dP: on or off	
		Touch SELECT 2 times	Power boost switch	Pb: on or off	
		Touch SELECT 3 times	Travel oil pressure switch	oP: on or off	
		Touch SELECT 4 times	One touch decel switch	od: on or off	
		Touch SELECT 5 times	Travel alarm switch	br: on or off	
		Touch SELECT 6 times	Preheat switch	PH: on or off	

Display group	How to select display mode		Name	Display on the cluster
	Group selection	Display mode selection		
Group 4 (Output)	Touch SELECT switch 4 times while pressing BUZZER STOP . In this group SELECT LED blinks at 1sec interval	Default	Hourmeter	H _o :on or oFF
		Touch SELECT 1 time	Neutral relay (Anti-restart relay)	n _r :on or oFF
		Touch SELECT 2 times	Travel speed solenoid	t _S :on or oFF
		Touch SELECT 3 times	Power boost solenoid (2-stage relief solenoid)	P _S :on or oFF
		Touch SELECT 4 times	Boom priority solenoid	b _S :on or oFF
		Touch SELECT 5 times	Travel alarm	A _l :on or oFF
		Touch SELECT 6 times	Max flow cut off solenoid	F _S :on or oFF
		Touch SELECT 7 times	Preheat relay	P _R :on or oFF

※ By touching **SELECT** switch once while pressing **BUZZER STOP**, display group shifts.

Example : Group 0 → 1 → 2 → 3 → 4 → 0

5. OPERATION OF WORKING DEVICE

※ **Confirm the operation of control lever and working device.**

- 1) Left control lever controls arm and swing.
- 2) Right control lever controls boom and bucket.
- 3) When you release the control lever, control lever returns to neutral position automatically.

※ **When operating swing, consider the swing distance by inertia.**

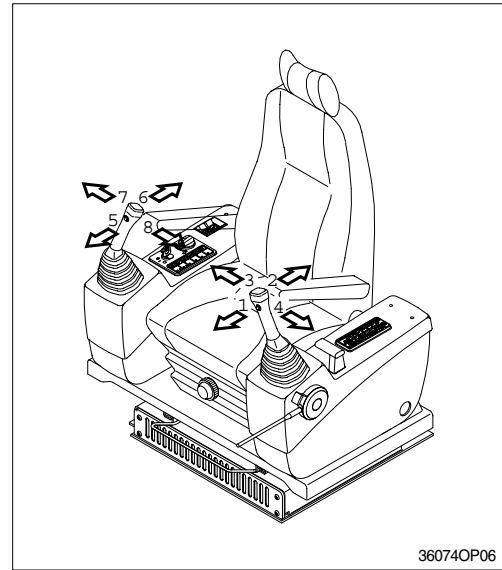

※ **Left control lever**

- 1 Arm roll-out
- 2 Arm roll-in
- 3 Swing right
- 4 Swing left

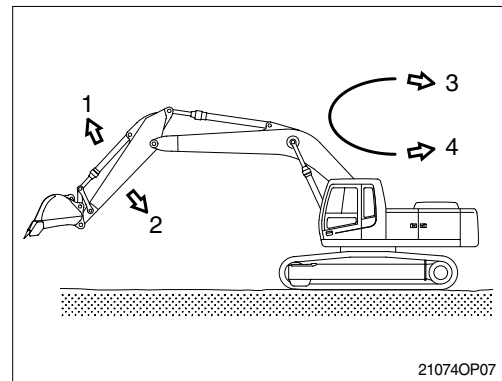

※ **Right control lever**

- 5 Boom lower
- 6 Boom raise
- 7 Bucket roll-out
- 8 Bucket roll-in

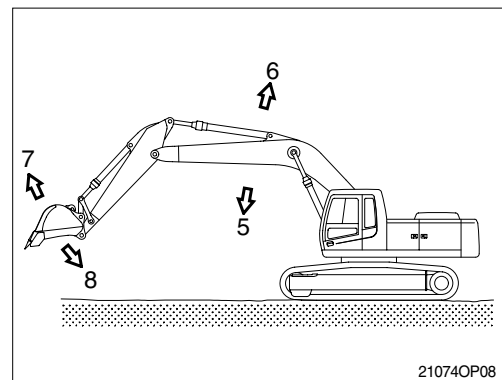

6. TRAVELING OF THE MACHINE

1) BASIC OPERATION

(1) Traveling position

It is the position which the traveling motor is in the rear and the working device is forward.

- ▲ **Be careful as the traveling direction will be reversed when the whole machine is swung 180 degree.**

(2) Traveling operation

It is possible to travel by either travel lever or pedal.

- ※ **Do not travel continuously for a long time.**
- ※ **Reduce the engine speed and travel at a low speed when traveling on uneven ground.**

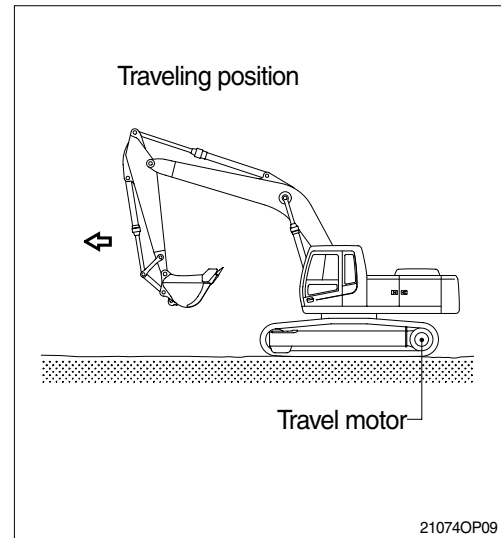

(3) Forward and backward traveling

When the left and right travel lever or pedal are pushed at the same time, the machine will travel forward or backward.

- ※ **The speed can be controlled by the operation stroke of lever or pedal and change of direction will be controlled by difference of the left and right stroke.**

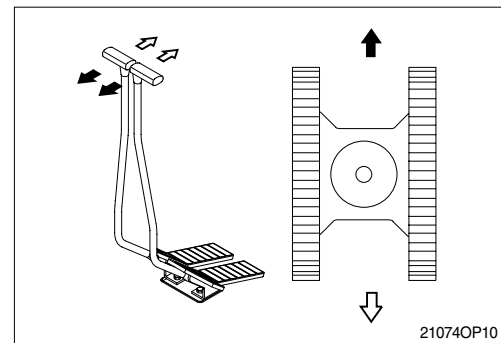

(4) Pivot turning

Operating only one side of lever or pedal make the change of direction possible by moving only one track.

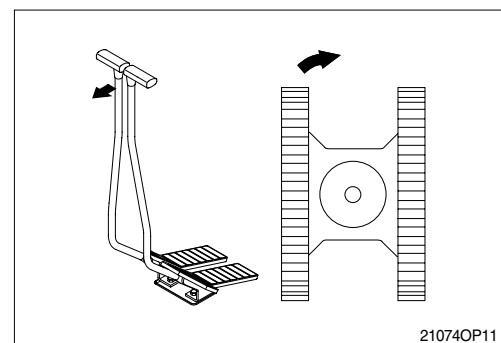

(5) Counter rotation

It is to change the direction at the original place by moving the right and left track. Both side of lever or pedal are operated to the other way at the same time.

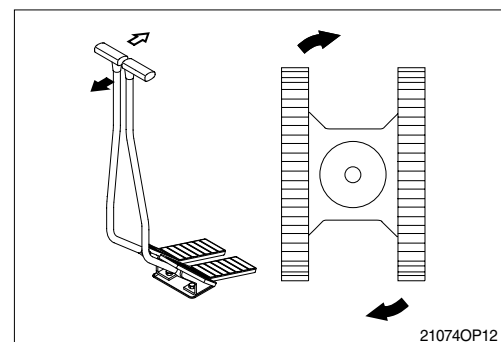

2) TRAVELING ON A SLOPE

- (1) Make sure that the travel lever is properly maneuvered by confirming the travel motor is in the right location.
 - (2) Lower the bucket 20 to 30cm(1ft) to the ground so that it can be used as a brake in an emergency.
 - (3) If the machine starts to slide or loses stability, lower the bucket immediately and brake the machine.
 - (4) When parking on a slope, use the bucket as a brake and place blocks behind the tracks to prevent sliding.
- ※ **Machine cannot travel effectively on a slope when the oil temperature is low. Do the warming-up operation when it is going to travel on a slope.**
- ▲ **Be careful when working on slopes. It may cause the machine to lose its balance and turn over.**
- ▲ **Be sure to keep the travel speed switch on the LOW(Turtle mark) while traveling on a slope.**

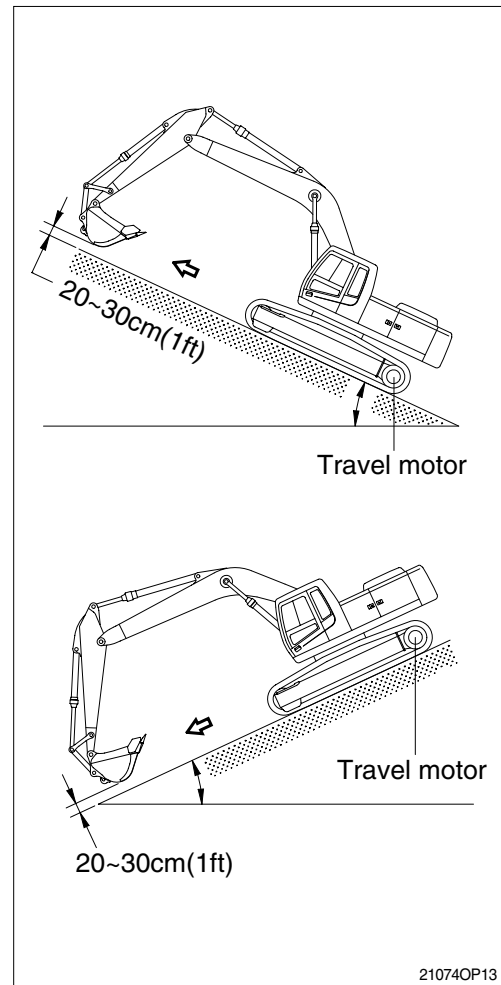

3) TRAVELING ON SOFT GROUND

- ※ **If possible, avoid to operate on soft ground.**
- (1) Move forward as far as machine can move.
 - (2) Take care not to go beyond the depth where towing is impossible on soft ground.
 - (3) When driving becomes impossible, lower bucket and use boom and arm to pull the machine. Operate boom, arm, and travel lever at the same time to avoid the machine sinking.

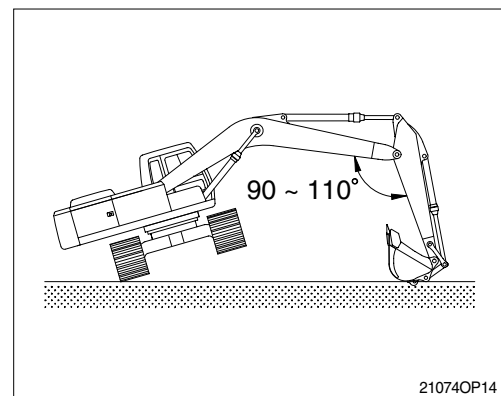

4) TOWING THE MACHINE

Tow the machine as follows when it can not move on it's own.

- (1) Tow the machine by other machine after hook the wire rope to the frame as shown in figure at right.
 - (2) Hook the wire rope to the frame and put a support under each part of wire rope to prevent damage.
- ※ **Never tow the machine using only the tie hole, because this may break.**
 - ▲ **Make sure no personnel are standing close to the tow rope.**

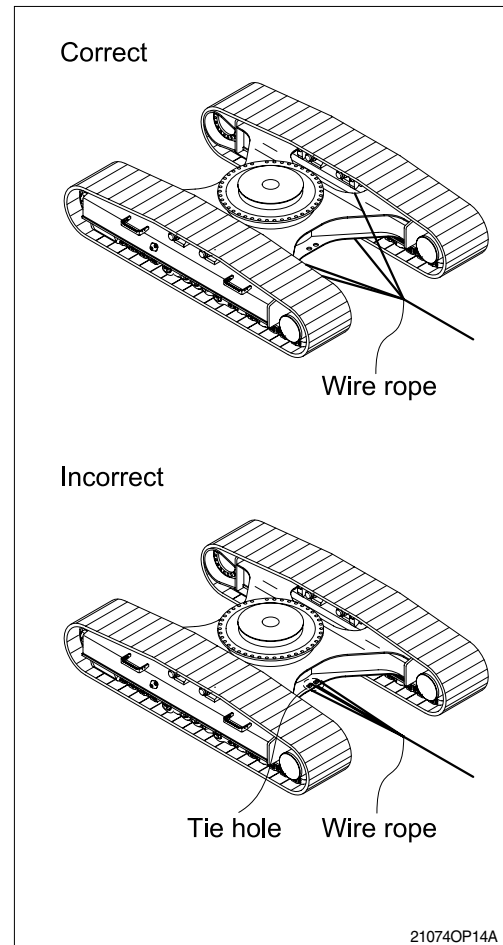

7. EFFICIENT WORKING METHOD

- 1) Do the digging work by arm.

Use the pulling force of arm for digging and use together with the digging force of the bucket if necessary.

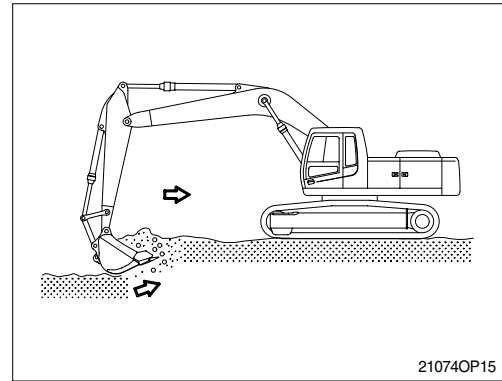

- 2) When lowering and raising the boom operate softly for the beginning and the end.

In particularly, sudden stops while lowering the boom may cause damage to the machine.

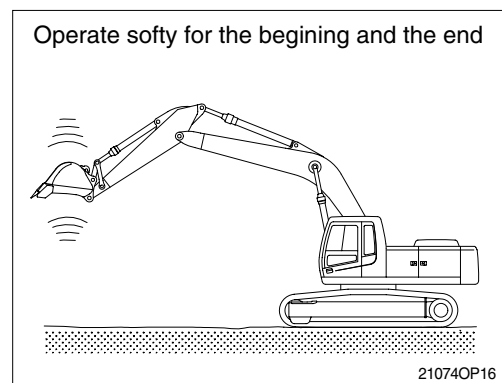

- 3) The digging resistance and wearing of tooth can be reduced by putting the end of bucket tooth to the digging direction.

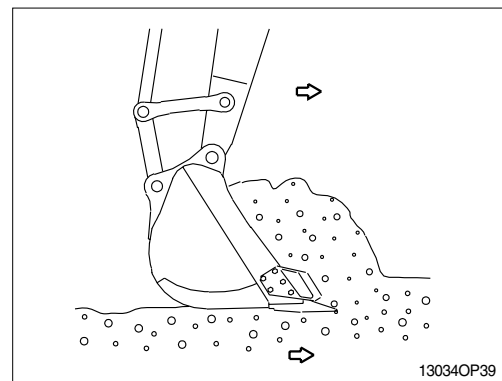

- 4) Set the tracks parallel to the line of the ditch to be excavated when digging ditch. Do not swing while digging.

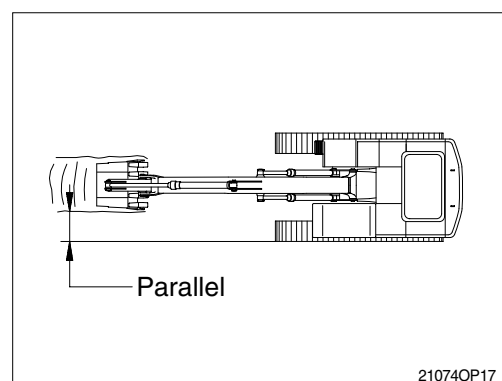

- 5) Dig slowly with keeping the angle of boom and arm, 90-110 degree when maximum digging force is required.

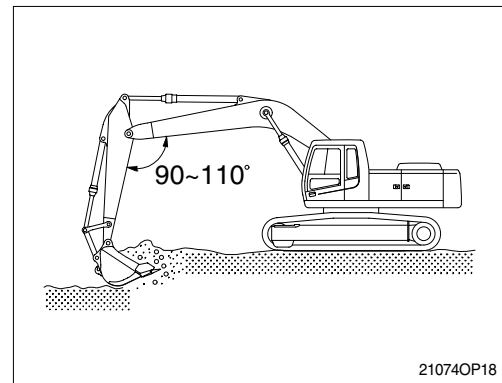

- 6) Operate leaving a small safety margin of cylinder stroke to prevent damage of cylinder when working with the machine.

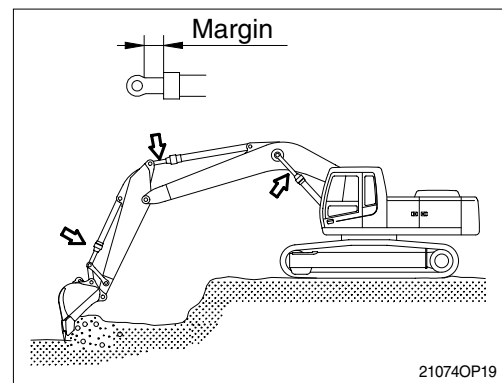

- 7) Keep the bucket to the dumping position and the arm horizontal when dumping the soil from the bucket.
Operate bucket lever 2 or 3 times when hard to dump.

※ Do not use the impact of bucket tooth when dumping.

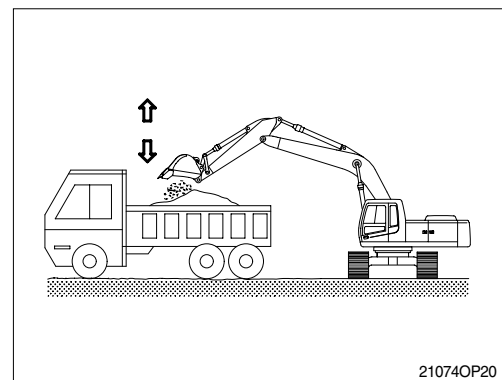

- 8) Operate stop of swing considering the swing slip distance is created by inertia after neutralizing the swing lever.

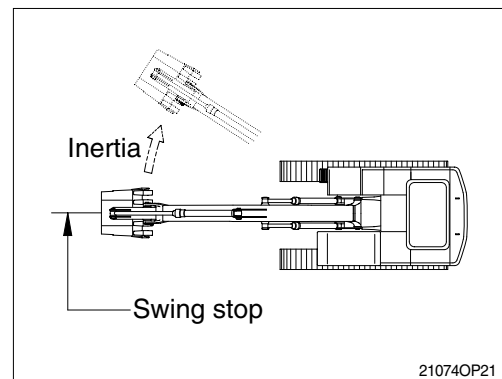

- 9) Do not use the dropping force of the work equipment for digging.
The machine can be damaged by the impact.

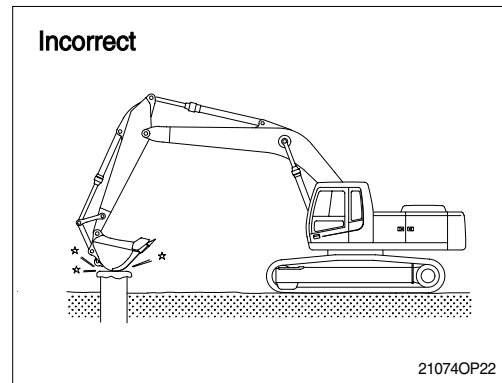

- 10) Do not use the bucket to crack hard objects like concrete or rocks.
This may break a tooth or pin, or bend boom.

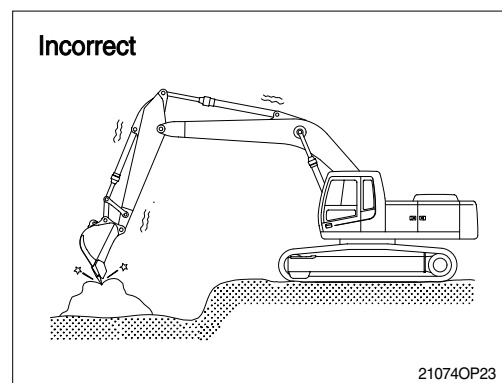

11) NEVER CARRY OUT EXCESSIVE OPERATIONS

Operation exceeding machine performance may result in accident or failure.
Carry out lifting operation within specified load limit.
Never carry out operations which may damage the machine such as overload or over-impact-load.
Never travel while carrying a load.
In case you need installing over load warning device for object handling procedure, please contact Hyundai distributor.

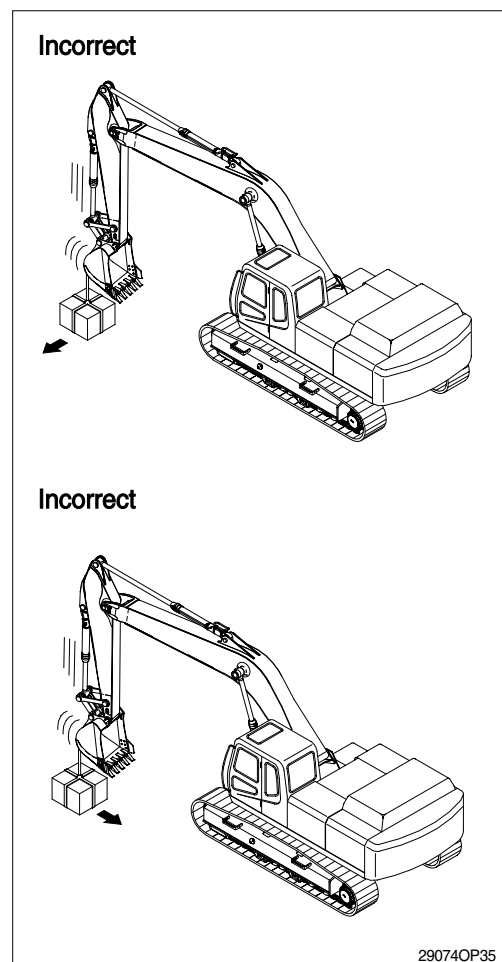

12) BUCKET WITH HOOK

When carrying out lifting work, the special lifting hook is necessary.

The following operations are prohibited.

- Lifting loads with a wire rope fitted around the bucket teeth.
- Lifting loads with the wire rope wrapped directly around the boom or arm.

When performing lifting operation, securely hook the wire rope onto the special lifting hook.

When performing lifting operation, never raise or lower a person.

Due to the possible danger of the load falling or of collision with the load, no persons shall be allowed in the working area.

Before performing lifting operation, designate an operation supervisor.

Always execute operation according to his instructions.

- Execute operating methods and procedures under his direction.
- Select a person responsible for signaling. Operate only on signals given by such person.

Never leave the operator's seat while lifting a load.

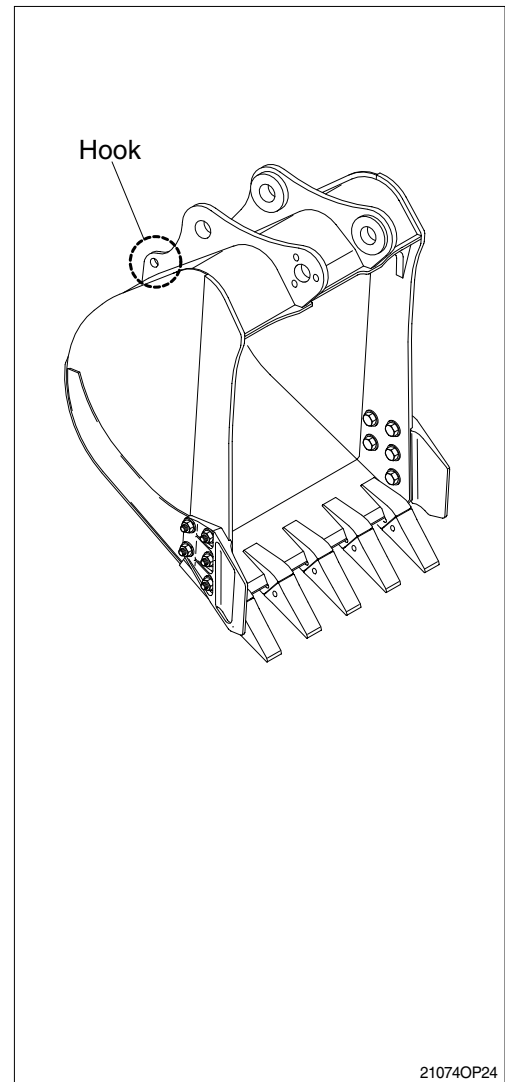

8. OPERATION IN THE SPECIAL WORK SITES

1) OPERATION THE MACHINE IN A COLD WEATHER

- (1) Use proper engine oil and fuel for the weather.
- (2) Fill the required amount of antifreeze in the coolant.
- (3) Refer to the starting engine in cold weather.
Start the engine and extend the warming up operation.
- (4) Be sure to open the heater cock when using the heater.
- (5) Always keep the battery completely charged.
※ **Discharged batteries will freeze more easily than fully charged.**
- (6) Clean the machine and park on the wood plates.

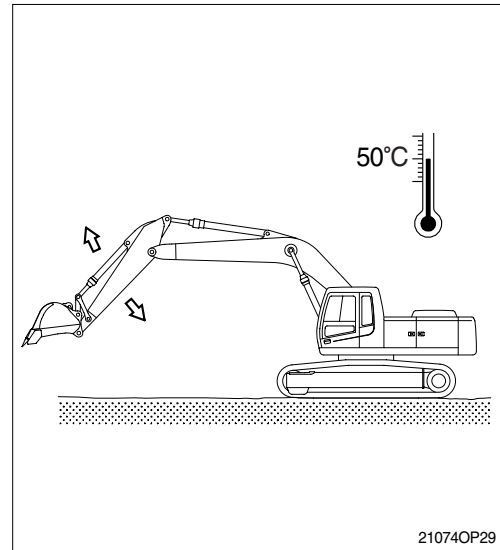

2) OPERATION IN SANDY OR DUSTY WORK SITES

- (1) Inspect air cleaner element frequently. Clean or replace element more frequently, if warning lamp comes ON and buzzer sounds simultaneously, regardless of inspection period.
※ **Replace the inner and outer element after 6 times of cleaning.**
- (2) Inspect radiator frequently, and keep cooling fins clean.
- (3) Prevent sand or dust from getting into fuel tank and hydraulic tank during refilling.
- (4) Prevent sand or dust from penetrating into hydraulic circuit by tightly closing breather cap of hydraulic oil tank. Replace hydraulic oil filter frequently.
- (5) Keep all lubricated part, such as pins and bushings, clean at all times.
- (6) If the air conditioner and heater filters clogged, the heating or cooling capacity will drop. Clean or replace the filter element more frequently.

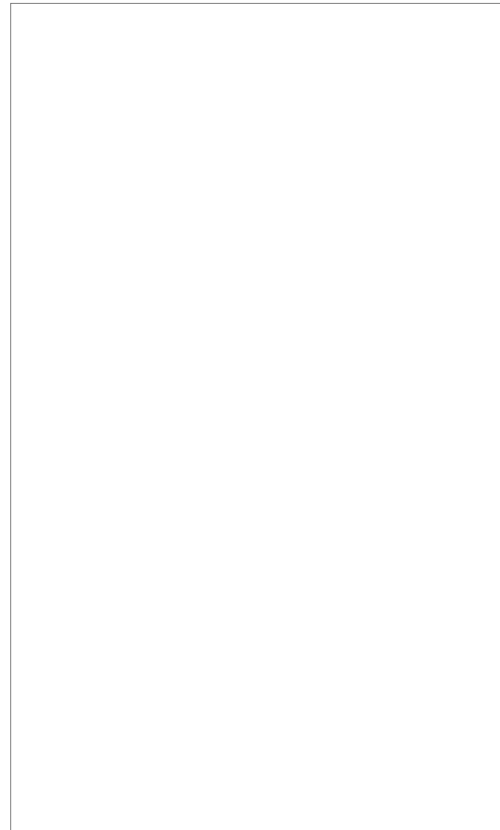

3) SEA SHORE OPERATION

- (1) Prevent ingress of salt by securely tightening plugs, cocks and bolts of each part.
- (2) Wash machine after operation to remove salt residue.
Pay special attention to electrical parts and hydraulic cylinders to prevent corrosion.
- (3) Inspection and lubrication must be carried out more frequently.
Supply sufficient grease to replace all old grease in bearings which have been submerged in water for a long time.

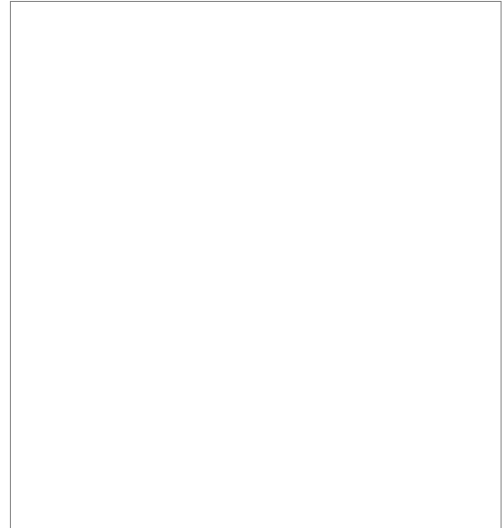

9. NORMAL OPERATION OF EXCAVATOR

Followings may occur during operation due to the nature of a hydraulic excavator.

- 1) When rolling in the arm, the roll-in movement stop momentary at point **X** in the picture shown, then recovers speed again after passing point **X**.
The reason for this phenomenon is that movement by the arm weight is faster than the speed of oil flow into the cylinder.
- 2) When lowering the boom, one may hear continuous sound.
This is caused by oil flow in the valve.
- 3) Overloaded movement will produce sound caused by the relief valves, which are for the protection of the hydraulic systems.
- 4) When the machine is started swing or stopped, a noise near the swing motor may be heard. The noise is generated when the brake valve relieves.

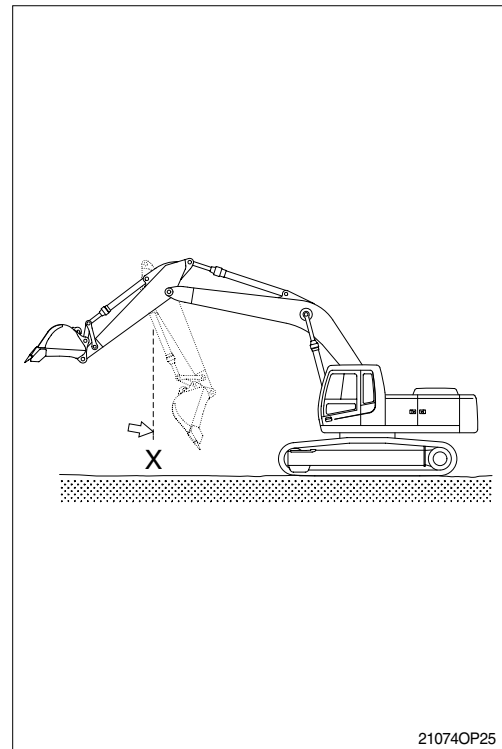

10. ATTACHMENT LOWERING(When engine is stopped)

1) On machines equipped with an accumulator, for a short time(within 2 minutes) after the engine is stopped, the attachment will lower under its own weight when the attachment control lever is shifted to LOWER. That is happen only starting switch ON position and safety lever UNLOCK position. After the engine is stopped, set the safety lever to the LOCK position.

▲ Be sure no one is under or near the attachment before lowering the boom.

2) The accumulator is filled with high-pressure nitrogen gas, and it is extremely dangerous if it is handled in the wrong way. Always observe the following precautions.

▲ Never make any hole in the accumulator expose it to flame or fire.

▲ Do not weld anything to the accumulator.

※ When carrying out disassembly or maintenance of the accumulator, it is necessary to release the gas from the accumulator. A special air bleed valve is necessary for this operation, so please contact your Hyundai distributor.

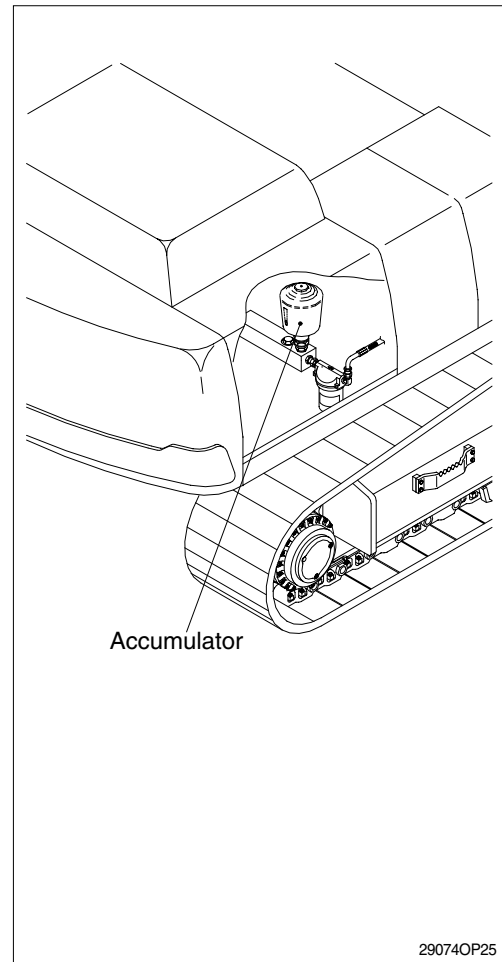

11. STORAGE

Maintain the machine taking care of following to prevent the deterioration of machine when storing the machine for a long time, over 1 month.

1) CLEANING THE MACHINE

Clean the machine. Check and adjust tracks.
Grease each lubrication part.

2) LUBRICATION POSITION OF EACH PART

Change all oil.

※ Be particularly careful when you reuse the machine.

As oil can be diluted during storage.

Apply an anticorrosive lubricant on the exposed part of piston rod of cylinder and in places where the machine rusts easily.

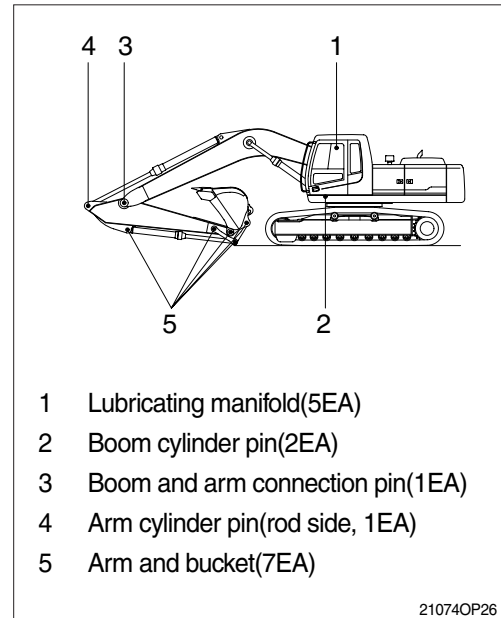

3) MASTER SWITCH

Turn OFF the master switch mounted electric box and store the machine.

4) Be sure to mix anticorrosive antifreezing solution in the radiator.

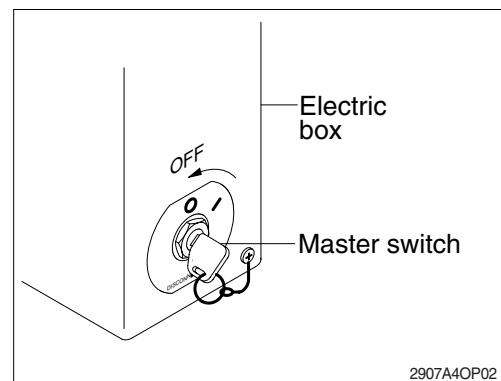

5) PREVENTION OF DUST AND MOISTURE

Keep machine dry. Store the machine setting wood on the ground.

※ Cover exposed part of piston rod of cylinder.

※ Lower the bucket to the ground and set a support under track.

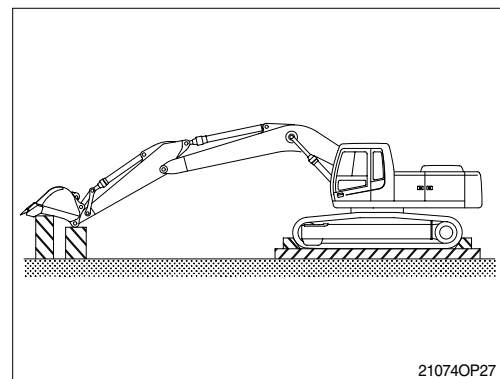

6) DURING STORAGE

Start engine and move the machine and work equipment once a month and apply lubrication to each part.

- ※ Check the level of engine oil and coolant and fill if required when starting engine.
- ※ Clean the anticorrosive on the piston rod of cylinder.
- ※ Operate the machine such as traveling, swing and work equipment operation to make sure enough lubrication of all functional components.

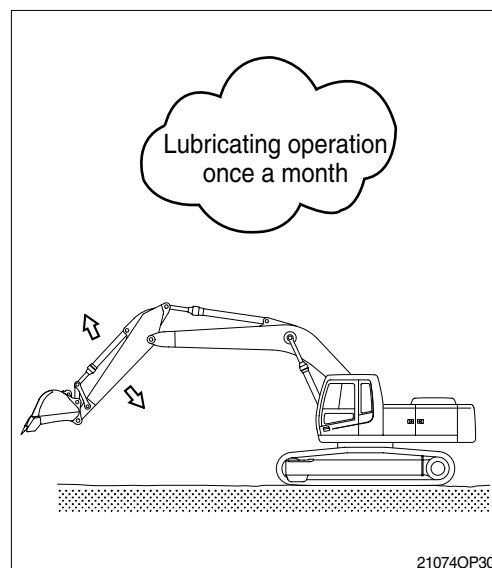

12. RCV LEVER OPERATING PATTERN

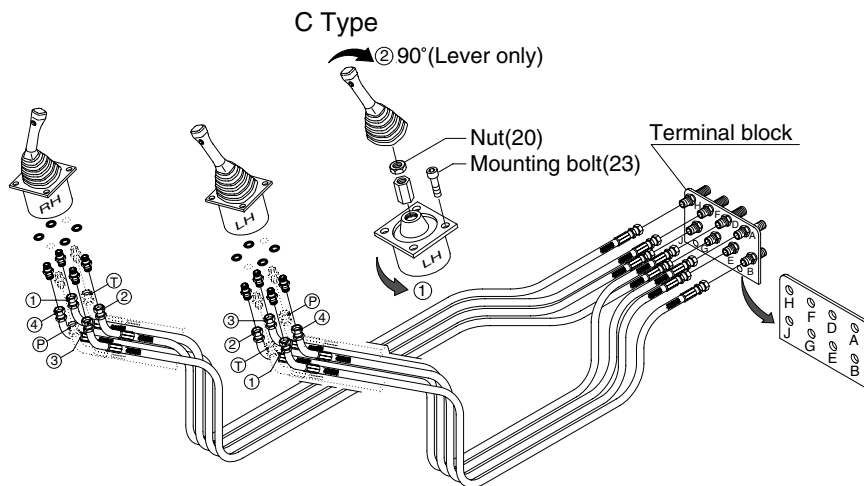

※ Whenever a change is made to the machine control pattern also exchange the pattern label in the cab to match the new pattern.

3207A4OP28

Pattern	Operation		Control function	Hose connection(Port)			
	Left	Right		RCV lever	Change of MCV port		
					From	To	
ISO Type			Left	Arm out	②	D	-
				Arm in	④	E	-
				Swing right	③	A	-
				Swing left	①	B	-
			Right	Boom lower	④	J	-
				Boom raise	②	H	-
				Bucket out	①	F	-
				Bucket in	③	G	-
Hyundai			Left	Boom lower	②	D	J
				Boom raise	④	E	H
				Swing right	③	A	-
				Swing left	①	B	-
			Right	Arm out	④	J	D
				Arm in	②	H	E
				Bucket out	①	F	-
				Bucket in	③	G	-
A Type			Left	Boom lower	②	D	J
				Boom raise	④	E	H
				Swing right	③	A	-
				Swing left	①	B	-
			Right	Arm out	④	J	D
				Arm in	②	H	E
				Bucket out	①	F	-
				Bucket in	③	G	-
B Type			Left	Boom lower	②	D	J
				Boom raise	④	E	H
				Bucket in	③	A	G
				Bucket out	①	B	F
			Right	Arm out	④	J	D
				Arm in	②	H	E
				Swing right	①	F	A
				Swing left	③	G	B
C Type			Left	① Loosen the RCV lever mounting bolt(21) and rotates lever assy 90° counterclockwise; then install. ② To put lever in correct position, disassemble nut(20) and rotates only lever 90° clockwise.			
			Right	Same as ISO type			

13. SWITCHING HYDRAULIC ATTACHMENT CIRCUIT

- 1) The combined hydraulic attachment circuit is capable of providing single action or double action.
- 2) The position of 3 way valve selects the single action hydraulic attachment circuit or the double action hydraulic attachment circuit.

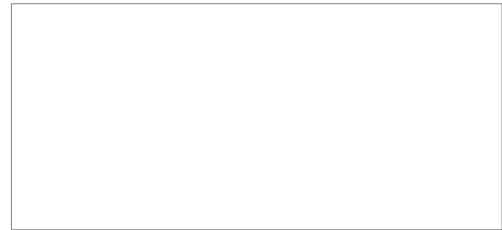

- 3) Before you change the flow mode of hydraulic attachment circuit, place the machine in the servicing position as shown. Stop the engine.

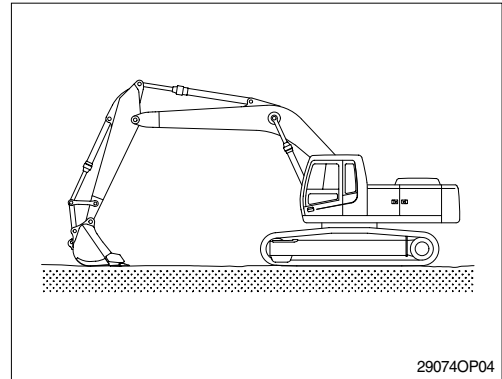

- 4) Use the manual lever to turn the 3 way valve. Make sure that you fully turn the valve until the valve stops.

(1) One way flow(Hydraulic breaker)

Position the manual lever parallel to the piping ().

(2) Two way flow(Clamshell or shear)

Position the manual lever perpendicular to the piping ().

