

## 1. INSTRUCTION

### 1) INTERVAL OF MAINTENANCE

- (1) You may inspect and service the machine by the period as described at page 6-11 based on hour meter at cluster.
- (2) Shorten the interval of inspect and service depending on site condition. (Such as dusty area, quarry, sea shore and etc.)
- (3) Practice the entire related details at the same time when the service interval is doubled.  
For example, in case of 100hours, carry out all the maintenance 「Each 100hours, each 50 hours and daily service」 at the same time.

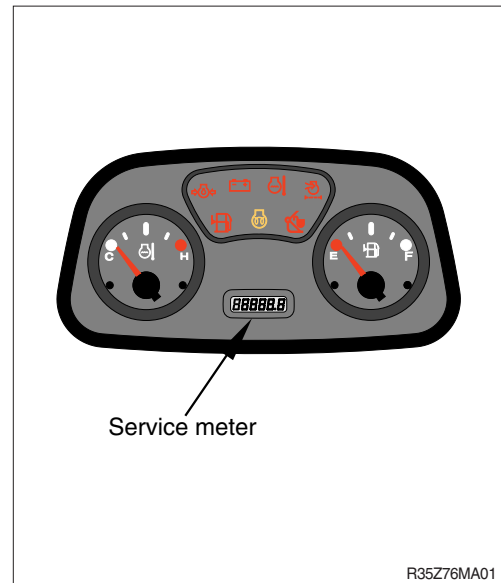

### 2) PRECAUTION

- (1) Start to maintenance after you have the full knowledge of machine.
- (2) The monitor installed on this machine does not entirely guarantee the condition of the machine.  
Daily inspection should be performed according to clause 4, maintenance check list.
- (3) Engine and hydraulic components have been preset in the factory.  
Do not allow unauthorized personnel to reset them.
- (4) Ask to your local dealer or Hyundai for the maintenance advice if unknown.
- (5) Drain the used oil and coolant in a container and handle according to the method of handling for industrial waste to meet with regulations of each province or country.

### 3) PROPER MAINTENANCE

(1) Replace and repair of parts

It is required to replace the wearable and consumable parts such as bucket tooth, side cutter, filter and etc., regularly.

Replace damaged or worn parts at proper time to keep the performance of machine.

(2) Use genuine parts.

(3) Use the recommended oil.

(4) Remove the dust or water around the inlet of oil tank before supplying oil.

(5) Drain oil when the temperature of oil is warm.

(6) Do not repair anything while operating the engine.

Stop the engine when you fill the oil.

(7) Relieve hydraulic system of the pressure before repairing the hydraulic system.

(8) Confirm if the cluster is in the normal condition after completion of service.

(9) For more detail information of maintenance, please contact local Hyundai dealer.

※ **Be sure to start the maintenance after fully understand the chapter 1, safety hints.**

#### 4) RELIEVING THE PRESSURE IN THE HYDRAULIC SYSTEM

※ Spouting of oil can cause the accident when loosening the cap or hose right after the operating of machine as the machine or oil is on the high pressure on the condition.

Be sure to relieve the pressure in the system before repairing hydraulic system.

- (1) Place machine in parking position, and stop the engine.

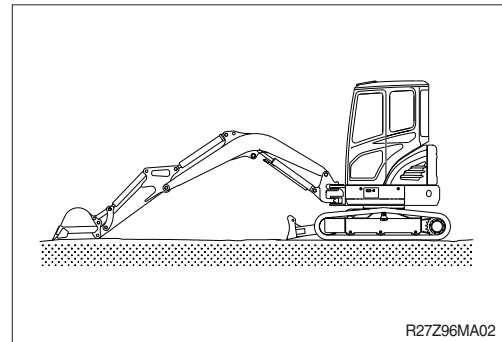

- (2) Set the safety lever completely in the release position, operate the control levers and pedals fully to the front, rear, left and right, to release the pressure in the hydraulic circuit.

※ This does not completely release the pressure, so when serving hydraulic component, loosen the connections slowly and do not stand in the direction where the oil spurt out.

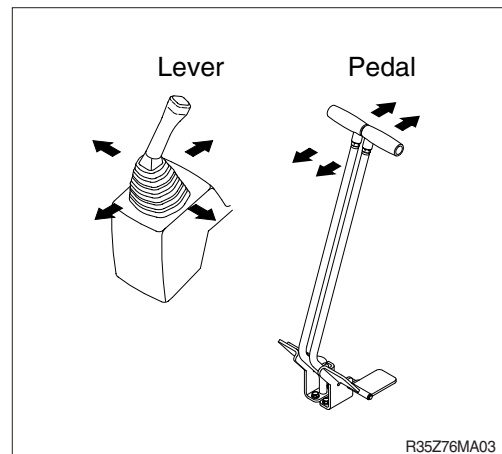

#### 5) PRECAUTION WHEN INSTALLING HYDRAULIC HOSES OR PIPES

- (1) Be particularly careful that the joint of hose, pipe and functioning item are not damaged.  
Avoid contamination.
- (2) Assemble after cleaning the hose, pipe and joint of functioning item.
- (3) Use genuine parts.
- (4) Do not assemble the hose in the condition of twisted or sharp radius.
- (5) Keep the specified tighten torque.

## 6) PERIODICAL REPLACEMENT OF SAFETY PARTS

(1) It is desirable to do periodic maintenance the machine for using the machine safely for a long time.

However, recommend to replace regularly the parts related safety not only safety but maintain satisfied performance.

(2) These parts can cause the disaster of life and material as the quality changes by passing time and it is worn, diluted, and gets fatigued by using repeatedly.

These are the parts which the operator can not judge the remained lifetime of them by visual inspection.

(3) Repair or replace if an abnormality of these parts is found even before the recommended replacement interval.

Periodical replacement of safety parts		Interval	
Engine	Fuel hose (tank-engine)	Every 2 years	
	Heater hose (heater-engine)		
Hydraulic system	Main circuit	Pump suction hose	Every 2 years
		Pump delivery hose	
		Swing hose	
	Working device	Boom cylinder line hose	Every 2 years
		Arm cylinder line hose	
		Bucket cylinder line hose	
		Dozer cylinder line hose	
		Boom swing cylinder line hose	

※ 1. Replace O-ring and gasket at the same time when replacing the hose.

2. Replace clamp at the same time if the hose clamp is cracked when checking and replacing the hose.

## 2. TIGHTENING TORQUE

Use following table for unspecified torque.

### 1) BOLT AND NUT

#### (1) Coarse thread

Bolt size	8T		10T	
	kgf · m	lbf · ft	kgf · m	lbf · ft
M 6 × 1.0	0.85 ~ 1.25	6.15 ~ 9.04	1.14 ~ 1.74	8.2 ~ 12.6
M 8 × 1.25	2.0 ~ 3.0	14.5 ~ 21.7	2.7 ~ 4.1	19.5 ~ 29.7
M10 × 1.5	4.0 ~ 6.0	28.9 ~ 43.4	5.5 ~ 8.3	39.8 ~ 60
M12 × 1.75	7.4 ~ 11.2	53.5 ~ 81.0	9.8 ~ 15.8	70.9 ~ 114
M14 × 2.0	12.2 ~ 16.6	88.2 ~ 120	16.7 ~ 22.5	121 ~ 163
M16 × 2.0	18.6 ~ 25.2	135 ~ 182	25.2 ~ 34.2	182 ~ 247
M18 × 2.5	25.8 ~ 35.0	187 ~ 253	35.1 ~ 47.5	254 ~ 344
M20 × 2.5	36.2 ~ 49.0	262 ~ 354	49.2 ~ 66.6	356 ~ 482
M22 × 2.5	48.3 ~ 63.3	349 ~ 458	65.8 ~ 98.0	476 ~ 709
M24 × 3.0	62.5 ~ 84.5	452 ~ 611	85.0 ~ 115	615 ~ 832
M30 × 3.0	124 ~ 168	898 ~ 1214	169 ~ 229	1223 ~ 1656
M36 × 4.0	174 ~ 236	1261 ~ 1704	250 ~ 310	1808 ~ 2242

#### (2) Fine thread

Bolt size	8T		10T	
	kgf · m	lbf · ft	kgf · m	lbf · ft
M 8 × 1.0	2.2 ~ 3.4	15.9 ~ 24.6	3.0 ~ 4.4	21.7 ~ 31.8
M10 × 1.2	4.5 ~ 6.7	32.5 ~ 48.5	5.9 ~ 8.9	42.7 ~ 64.4
M12 × 1.25	7.8 ~ 11.6	56.4 ~ 83.9	10.6 ~ 16.0	76.7 ~ 116
M14 × 1.5	13.3 ~ 18.1	96.2 ~ 131	17.9 ~ 24.1	130 ~ 174
M16 × 1.5	19.9 ~ 26.9	144 ~ 195	26.6 ~ 36.0	192 ~ 260
M18 × 1.5	28.6 ~ 43.6	207 ~ 315	38.4 ~ 52.0	278 ~ 376
M20 × 1.5	40.0 ~ 54.0	289 ~ 391	53.4 ~ 72.2	386 ~ 522
M22 × 1.5	52.7 ~ 71.3	381 ~ 516	70.7 ~ 95.7	511 ~ 692
M24 × 2.0	67.9 ~ 91.9	491 ~ 665	90.9 ~ 123	658 ~ 890
M30 × 2.0	137 ~ 185	990 ~ 1339	182 ~ 248	1314 ~ 1796
M36 × 3.0	192 ~ 260	1390 ~ 1880	262 ~ 354	1894 ~ 2562

**2) PIPE AND HOSE (FLARE type)**

Thread size (PF)	Width across flat (mm)	kgf · m	lbf · ft
1/4"	19	4	28.9
3/8"	22	5	36.2
1/2"	27	9.5	68.7
3/4"	36	18	130
1"	41	21	152
1-1/4"	50	35	253

**3) PIPE AND HOSE (ORFS type)**

Thread size (UNF)	Width across flat (mm)	kgf · m	lbf · ft
9/16-18	19	4	28.9
11/16-16	22	5	36.2
13/16-16	27	9.5	68.7
1-3/16-12	36	18	130
1-7/16-12	41	21	152
1-11/16-12	50	35	253

**4) FITTING**

Thread size	Width across flat (mm)	kgf · m	lbf · ft
1/4"	19	4	28.9
3/8"	22	5	36.2
1/2"	27	9.5	68.7
3/4"	36	18	130
1"	41	21	152
1-1/4"	50	35	253

#### 4) TIGHTENING TORQUE OF MAJOR COMPONENT

No.	Descriptions	Bolt size	Torque		
			kgf · m	lbf · ft	
1	Engine	Engine mounting bolt (engine-Bracket)	M10 × 1.5	7.3±1.0	53±7.2
2		Engine mounting bolt (bracket-Frame)	M12 × 1.75	10±1.0	72±7.2
3		Radiator mounting bolt, nut	M 8 × 1.25	1.17±0.1	8.5±0.7
4		Coupling mounting bolt	M12 × 1.75	9.25±0.25	67±1.8
5	Hydraulic system	Main pump mounting bolt	M12 × 1.75	10±1.0	72±7.2
6		Main control valve mounting bolt	M10 × 1.5	6.9±1.4	50±10.0
7		Fuel tank mounting bolt	M12 × 1.75	12.8±3.0	93±22.0
8		Hydraulic oil tank mounting bolt	M12 × 1.75	12.8±3.0	93±22.0
9		Turning joint mounting bolt, nut	M10 × 1.5	6.9±1.4	50±10.0
10	Power train system	Swing motor mounting bolt	M14 × 2.0	19.6±2.9	142±21.0
11		Swing bearing upper mounting bolt	M12 × 1.75	12.8±3.0	93±22.0
12		Swing bearing lower mounting bolt	M12 × 1.75	12.8±3.0	93±22.0
13		Travel motor mounting bolt	M12 × 1.75	13.8±2.0	100±14.0
14		Sprocket mounting bolt	M12 × 1.75	12.8±3.0	93±22.0
15	Under carriage	Carrier roller mounting bolt, nut	M12 × 1.75	12.8±3.0	93±22.0
16		Track roller mounting bolt	M16 × 2.0	29.7±4.0	215±29.0
17	Others	Counter weight mounting bolt	M20 × 2.5	57.8±6.4	418±46.3
18		Cab mounting bolt, nut	M12 × 1.75	12.8±3.0	92±22.0
19		Operator's seat mounting bolt	M 8 × 1.25	1.17±0.1	8.5±0.7

### 3. FUEL, COOLANT AND LUBRICANTS

#### 1) NEW MACHINE

New machine used and filled with following lubricants.

Description	Specification
Engine oil	SAE 15W-40 (API CH-4)
Hydraulic oil	Hyundai genuine long life hydraulic oil (ISO VG 46, VG 68) Conventional hydraulic oil (ISO VG 32 only)
Swing and travel reduction gear	SAE 85W-140 (API GL-5)
Grease	Lithium base grease NLGI No. 2
Fuel	ASTM D975-No. 2
Coolant	Mixture of 50% ethylene glycol base antifreeze and 50% water.

SAE : Society of Automotive Engineers

API : American Petroleum Institute

ISO : International Organization for Standardization

NLGI : National Lubricating Grease Institute

ASTM : American Society of Testing and Material

## 2) RECOMMENDED OILS

Use only oils listed below or equivalent.

Do not mix different brand oil.

Service point	Kind of fluid	Capacity l (U.S. gal)	Ambient temperature °C ( °F)							
			-20 (-4)	-10 (14)	0 (32)	10 (50)	20 (68)	30 (86)	40 (104)	
Engine oil pan	Engine oil	5.9 (1.6)				SAE 30				
			SAE 10W							
			SAE 10W-30							
						SAE 15W-40				
Final drive	Gear oil	0.6×2 (0.16×2)		SAE 85W-140						
Hydraulic tank	Hydraulic oil	Tank: 32 (8.5) System: 60 (15.9)	ISO VG 32							
			ISO VG 46							
			ISO VG 68							
Fuel tank	Diesel fuel	38 (10)	ASTM D975 NO.1							
			ASTM D975 NO.2							
Fitting (Grease nipple)	Grease	As required	NLGI NO.1							
			NLGI NO.2							
Radiator (Reservoir tank)	Mixture of antifreeze and water 50 : 50	5 (1.3)	Ethylene glycol base permanent type							

**SAE** : Society of Automotive Engineers

**API** : American Petroleum Institute

**ISO** : International Organization for Standardization

**NLGI** : National Lubricating Grease Institute

**ASTM** : American Society of Testing and Material

## 4. MAINTENANCE CHECK LIST

### 1) DAILY SERVICE BEFORE STARTING

Check items	Service	Page
Visual check		
Fuel tank	Check, Refill	6-24
Hydraulic oil level	Check, Add	6-26
Engine oil level	Check, Add	6-17
Coolant level	Check, Add	6-19
Control panel & pilot lamp	Check, Clean	6-34
Water separator	Check, Drain	6-24
Fan belt tension	Check, Adjust	6-22
★ Attachment pins	Lubricate	6-41
· Boom cylinder head and rod		
· Boom connecting		
· Arm cylinder head and rod		
· Boom + Arm connecting		
· Bucket cylinder head		

★ Lubricate every 10 hours or daily for initial 100 hours.

### 2) EVERY 50 HOURS SERVICE

Check items	Service	Page
Fuel tank	Drain	6-24
Track tension	Check, Adjust	6-30
Swing bearing	Lubricate	6-28
Swing reduction gear grease	Lubricate	6-28
Lubricate pin and bushing	Lubricate	6-33
· Bucket cylinder rod		
· Arm + Bucket connecting		
· Arm + Link, Bucket control		
· Bucket control rod		
· Boom swing post + Upper frame connecting		
· Boom swing cylinder head and rod		
· Dozer blade + Lower frame connecting		
· Dozer blade cylinder head and rod		

### 3) INITIAL 50 HOURS SERVICE

Check items	Service	Page
Engine oil	Change	6-17, 18
Engine oil filter	Replace	6-17, 18
Pilot line filter	Replace	6-28
Hydraulic return filter	Replace	6-27
Fuel filter	Replace	6-25
Bolts & Nuts	Check, Tight	6-7
<ul style="list-style-type: none"> <li>· Sprocket mounting bolts</li> <li>· Travel motor mounting bolts</li> <li>· Swing motor mounting bolts</li> <li>· Swing bearing mounting bolts</li> <li>· Engine mounting bolts</li> <li>· Counterweight mounting bolts</li> <li>· Turning joint locating bolts</li> <li>· Track shoe mounting bolts and nuts</li> <li>· Hydraulic pump mounting bolts</li> </ul>		

※ **Service the above items only for the new machine, and thereafter keep the normal service interval.**

### 4) EVERY 100 HOURS SERVICE

Check items	Service	Page
★ Return filter	Replace	6-27
★ Pilot line filter	Replace	6-28

★ **Replace 2 filters for continuous hydraulic breaker operation only.**

### 5) EVERY 250 HOURS SERVICE

Check items	Service	Page
★Engine oil	Change	6-17, 18
★Engine oil filter	Replace	6-17, 18
Battery (voltage)	Check	6-34
Bolts & Nuts	Check, Tight	6-7
· Sprocket mounting bolts		
· Travel motor mounting bolts		
· Swing motor mounting bolts		
· Swing bearing mounting bolts		
· Engine mounting bolts		
· Counterweight mounting bolts		
· Turning joint locating bolts		
· Track shoe mounting bolts and nuts		
· Hydraulic pump mounting bolts		
Attachment pins	Lubricate	6-41
· Boom cylinder head and rod		
· Boom connecting		
· Arm cylinder head and rod		
· Boom + Arm connecting		
· Bucket cylinder head		

★ If you use high sulfur containing fuel above than 0.5% or use low grade of engine oil reduce change interval.

### 6) INITIAL 250 HOURS SERVICE

Check items	Service	Page
Pilot line filter	Replace	6-28
Hydraulic oil return filter	Replace	6-27

### 7) EVERY 400 HOURS SERVICE

Check items	Service	Page
Fuel filter	Replace	6-25

### 8) EVERY 500 HOURS SERVICE

Check items	Service	Page
Radiator and cooler fin	Check, Clean	6-22
☆ Air cleaner element	Inspect, Clean	6-23
◆ Travel reduction gear oil	Change	6-29

- ☆ Clean the primary element only after 500 hours operation or when the air cleaner warning lamp blinks.  
Replace primary element and safety element after 4 times cleanings of primary element.
- ◆ Change oil after initial 500 hours of operation.

### 9) EVERY 1000 HOURS SERVICE

Check items	Service	Page
Travel motor reduction gear oil	Change	6-29
Hydraulic oil return filter	Replace	6-28
Pilot line filter	Replace	6-27

### 10) EVERY 2000 HOURS SERVICE

Check items	Service	Page
Coolant	Change	6-20, 21, 22, 23
Hydraulic oil * <sup>1</sup>	Change	6-26
Hydraulic tank suction strainer	Check, Clean	6-27

\*<sup>1</sup> Conventional hydraulic oil

- ※ Change oil every 600 hours of continuous hydraulic breaker operation.

### 11) EVERY 5000 HOURS SERVICE

Check items	Service	Page
Hydraulic oil * <sup>2</sup>	Change	6-26

\*<sup>2</sup> Hyundai genuine long life hydraulic oil

- ※ Change oil every 1000 hours of continuous hydraulic breaker operation.

## 12) WHEN REQUIRED

Whenever you have trouble in the machine, you must perform the service of related items, system by system.

Check items	Service	Page
Fuel system		
· Fuel tank	Drain or Clean	6-24
· Water separator	Drain or Replace	6-24
· Fuel filter	Replace	6-25
Engine lubrication system		
· Engine oil	Change	6-17, 18
· Engine oil filter	Replace	6-17, 18
Engine cooling system		
· Coolant	Add or Change	6-19, 20, 21, 22
· Radiator	Clean or Flush	6-19, 20, 21, 22
Engine air system		
· Air cleaner	Replace	6-23
Hydraulic system		
· Hydraulic oil	Add or Change	6-26
· Return filter	Replace	6-27
· Pilot line filter	Replace	6-28
· Suction strainer	Clean	6-27
Under carriage		
· Track tension	Check, Adjust	6-30
Bucket		
· Tooth	Replace	6-32
· Side cutter	Replace	6-31
· Linkage	Adjust	6-31
· Bucket assy	Replace	6-31
Heater		
· Heater filter	Clean	6-37

## 5. MAINTENANCE CHART

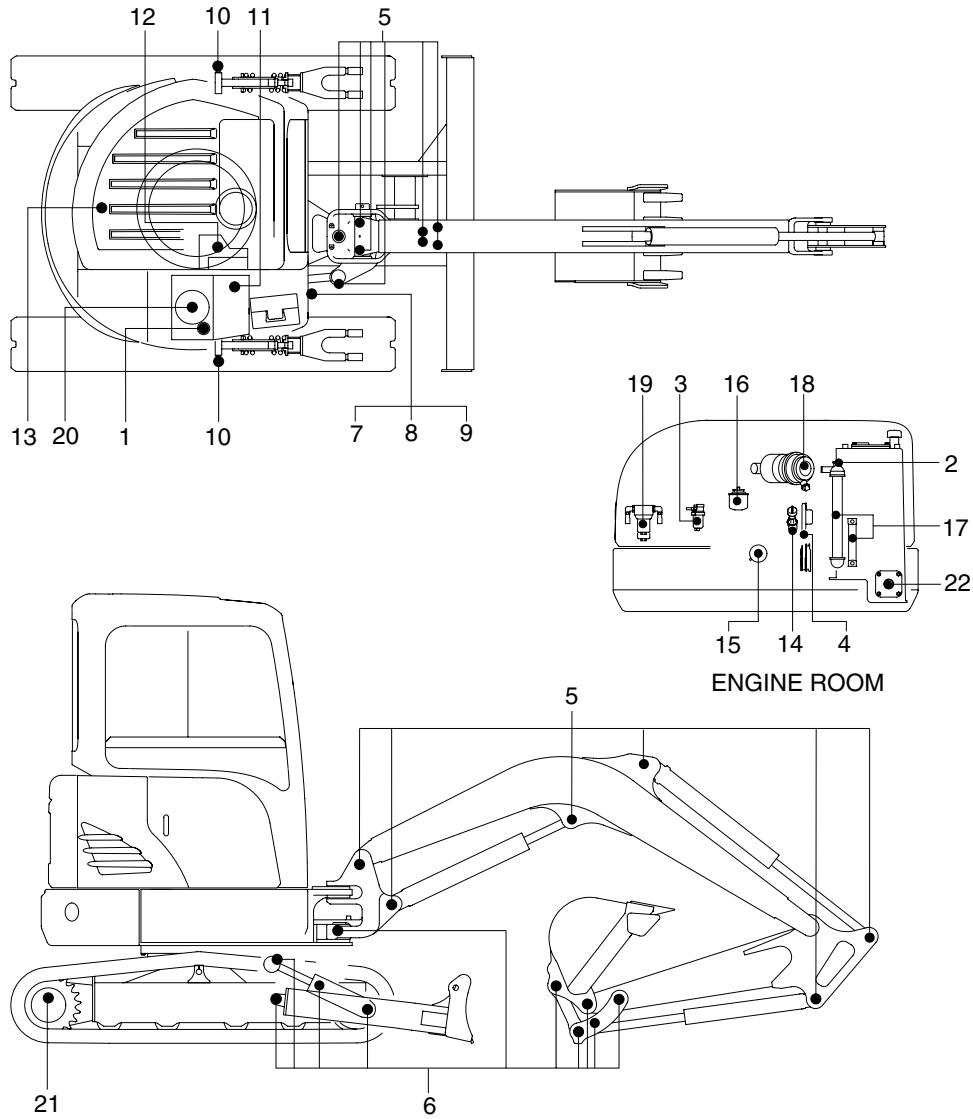

R27Z96MA30

### Caution

1. Service intervals are based on the hour meter reading.
2. The number of each item shows the lubrication point on the machine.
3. Stop engine while filling oil, and use no open flames.
4. For other details, refer to the service manual.

Service interval	No.	Description	Service action	Oil symbol	Capacity / (U.S.gal)	Service points No.
10 Hours or daily	1	Hydraulic oil level	Check, Add	HO	32 (8.5)	1
	2	Radiator coolant	Check, Add	C	5 (1.3)	1
	3	Water separator	Drain	-	-	1
	4	Fan belt tension and damage	Check, Adjust	-	-	1
	14	Engine oil level	Check, Add	EO	5.9 (1.5)	1
50 Hours or weekly	6	Bucket linkage & blade pins	Check, Add	PGL	-	6
	7	Boom swing cylinder	Lubricate	PGL	-	1
	8	Swing bearing	Lubricate	PGL	-	1
	9	Swing gear and pinion	Check, Add	PGL	-	1
	10	Track tension	Check, Adjust	PGL	-	2
	11	Fuel tank (water, sediment)	Check, Clean	-	-	1
250 Hours	5	Attachment pins	Check, Add	PGL	-	9
	13	Battery (voltage)	Check, Clean	-	-	1
	14	Engine oil	Change	EO	5.9 (1.6)	1
	15	Engine oil filter	Replace	-	-	1
400 Hours	16	Fuel filter element	Replace	-	-	1
500 Hours	17	Radiator and cooler fin	Check, Clean	-	-	2
	18	Air cleaner element (outside)	Clean	-	-	1
1000 Hours	19	Line filter element	Change	-	-	1
	20	Hydraulic oil return filter	Change	-	-	1
	21	Travel reduction gear case	Change	GO	0.6 (0.16)	2
2000 Hours	1	Hydraulic oil * <sup>1</sup>	Change	HO	32 (8.5)	1
	2	Radiator coolant	Change	C	5 (1.3)	1
	22	Hydraulic oil suction strainer	Check, Clean	-	-	1
5000 Hours	1	Hydraulic oil * <sup>2</sup>	Change	HO	32 (8.5)	1
As required	12	Heater filter	Check, Clean	-	-	1
	18	Air cleaner element (inside/outside)	Check, Clean	-	-	2

\*<sup>1</sup> Conventional hydraulic oil

\*<sup>2</sup> Hyundai genuine long life hydraulic oil

※ Oil symbol

Please refer to the recommended lubricants for specification.

DF : Diesel fuel

GO : Gear oil

HO : Hydraulic oil

C : Coolant

PGL : Grease

EO : Engine oil