

## 5. MAINTENANCE CHART

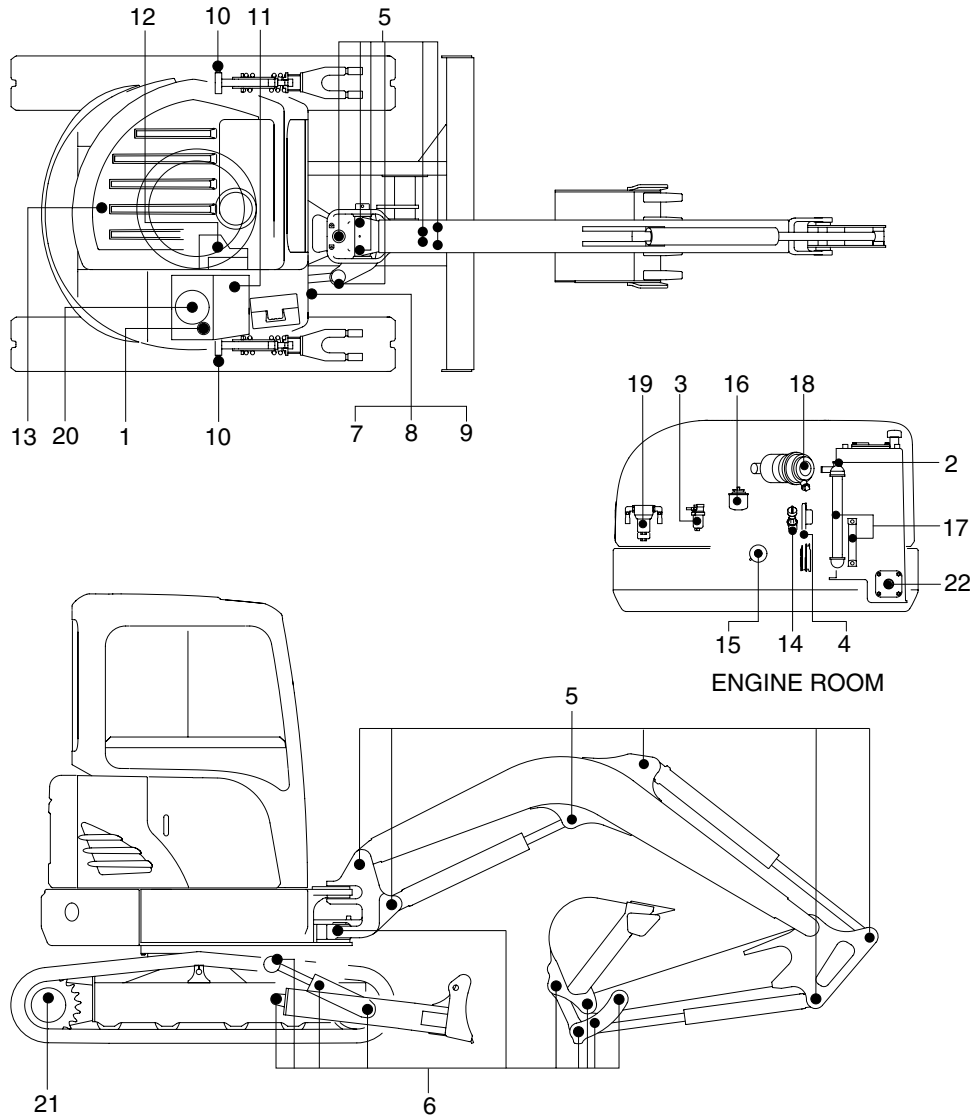

R27Z96MA30

### Caution

1. Service intervals are based on the hour meter reading.
2. The number of each item shows the lubrication point on the machine.
3. Stop engine while filling oil, and use no open flames.
4. For other details, refer to the service manual.

Service interval	No.	Description	Service action	Oil symbol	Capacity / (U.S.gal)	Service points No.
10 Hours or daily	1	Hydraulic oil level	Check, Add	HO	32 (8.5)	1
	2	Radiator coolant	Check, Add	C	5 (1.3)	1
	3	Water separator	Drain	-	-	1
	4	Fan belt tension and damage	Check, Adjust	-	-	1
	14	Engine oil level	Check, Add	EO	5.9 (1.5)	1
50 Hours or weekly	6	Bucket linkage & blade pins	Check, Add	PGL	-	6
	7	Boom swing cylinder	Lubricate	PGL	-	1
	8	Swing bearing	Lubricate	PGL	-	1
	9	Swing gear and pinion	Check, Add	PGL	-	1
	10	Track tension	Check, Adjust	PGL	-	2
	11	Fuel tank (water, sediment)	Check, Clean	-	-	1
250 Hours	5	Attachment pins	Check, Add	PGL	-	9
	13	Battery (voltage)	Check, Clean	-	-	1
	14	Engine oil	Change	EO	5.9 (1.6)	1
	15	Engine oil filter	Replace	-	-	1
400 Hours	16	Fuel filter element	Replace	-	-	1
500 Hours	17	Radiator and cooler fin	Check, Clean	-	-	2
	18	Air cleaner element (outside)	Clean	-	-	1
1000 Hours	19	Line filter element	Change	-	-	1
	20	Hydraulic oil return filter	Change	-	-	1
	21	Travel reduction gear case	Change	GO	0.6 (0.16)	2
2000 Hours	1	Hydraulic oil * <sup>1</sup>	Change	HO	32 (8.5)	1
	2	Radiator coolant	Change	C	5 (1.3)	1
	22	Hydraulic oil suction strainer	Check, Clean	-	-	1
5000 Hours	1	Hydraulic oil * <sup>2</sup>	Change	HO	32 (8.5)	1
As required	12	Heater filter	Check, Clean	-	-	1
	18	Air cleaner element (inside/outside)	Check, Clean	-	-	2

\*<sup>1</sup> Conventional hydraulic oil

\*<sup>2</sup> Hyundai genuine long life hydraulic oil

※ Oil symbol

Please refer to the recommended lubricants for specification.

DF : Diesel fuel

GO : Gear oil

HO : Hydraulic oil

C : Coolant

PGL : Grease

EO : Engine oil