

## 4. MODE SELECTION SYSTEM

### 1) STRUCTURE OF MECHATRONICS SYSTEM

CAPO, Computer Aided Power Optimization system, is the name of mode selection system developed by Hyundai.

※ Please refer to chapter 3, cluster for below modes setting.

#### (1) Power mode

Power mode designed for various work loads supports high performance and reduces fuel consumption.

- P mode : Heavy duty power
- S mode : Standard power
- E mode : Economy power

#### (2) Work mode

One of the two work modes can be selected for the optimal work condition of the machine operation.

##### ① General work mode (bucket)

When key switch is turned ON, this mode is selected automatically.

##### ② Work tool mode (breaker, crusher)

It controls the pump flow and system pressure for the optimal operation of breaker or crusher.

#### (3) User mode

① User mode is useful for setting the user preferable power quickly.

(engine speed, power shift and idle speed)

② There are two methods for use of user mode.

##### a. In operation screen

User mode switch is used to memorize the current machine operating status and activate the memorized user mode.

Refer to page 3-10.

##### b. In menu

Engine high idle rpm, auto idle rpm and pump torque (power shift) can be modulated and memorized separately in menu status.

- Each memory mode has a initial set which are mid-range of max engine speed, power shift and auto idle speed.

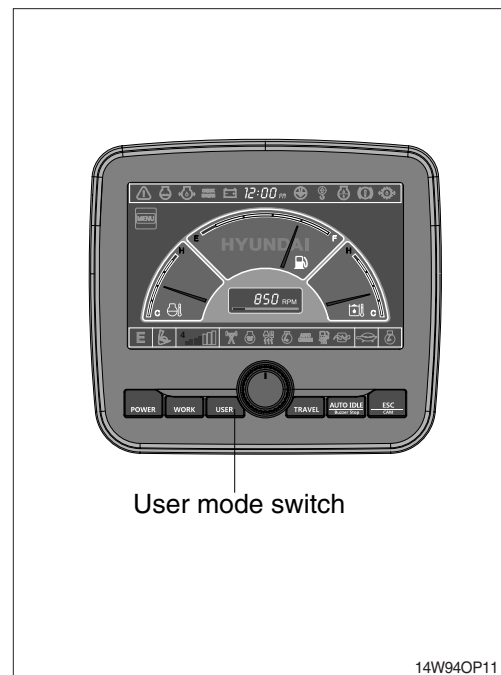
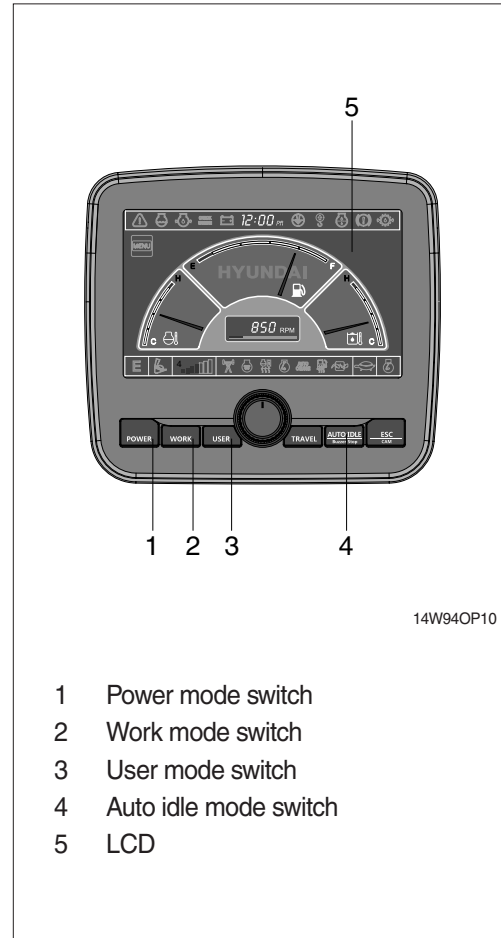

- High idle rpm, auto idle rpm and EPPR pressure can be adjusted and memorized in the U-mode.

※ Refer to the page 3-12 for setting the user mode (available on U mode only).

· LCD segment vs parameter setting

Step (■)	Engine speed (rpm)	Idle speed (rpm)	Power shift (bar)
1	1250	700	0
2	1300	750	3
3	1350	800	6
4	1400	850 (low idle)	9
5	1450	900	12
6	1500	950	16
7	1550	1000 (decel rpm)	20
8	1600	1050	26
9	1650	1100	32
10	1700	1150	38

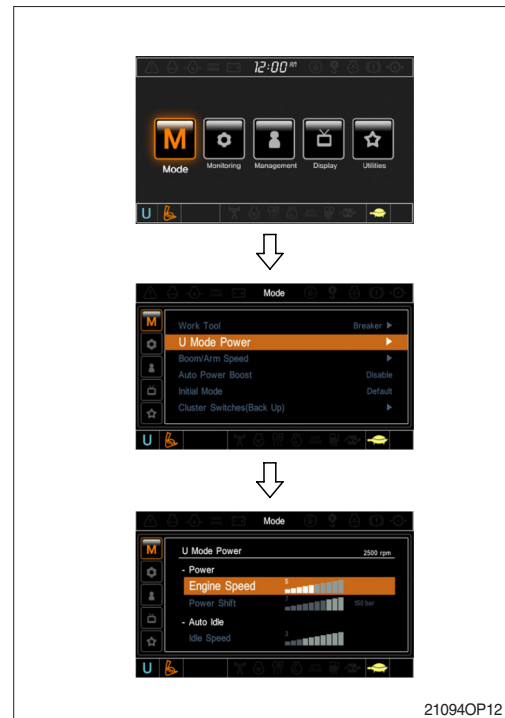

21094OP12

#### (4) Auto idle mode

Pilot lamp ON : Auto idle function is activated.

Pilot lamp OFF : Auto idle function is canceled.

## (6) Monitoring system

Information of machine performance as monitored by the MCU can be displayed on the LCD. Refer to the page 3-11.

## (7) Self diagnostic system

### ① MCU (Machine Control Unit)

The MCU diagnoses machine status and problems and displays fault code in the cluster (fault code detected by MCU is composed of HCESPN and FMI).

### ② Engine ECM (Electronic Control Module)

If the engine or relevant system has problem, engine ECM detects and displays on the LCD as fault codes (this code is composed of SPN and FMI).

※ Refer to the page 3-11 for LCD display.

## (8) Anti-restart system

The system protects the starter from inadvertent restarting after the engine is already operational.

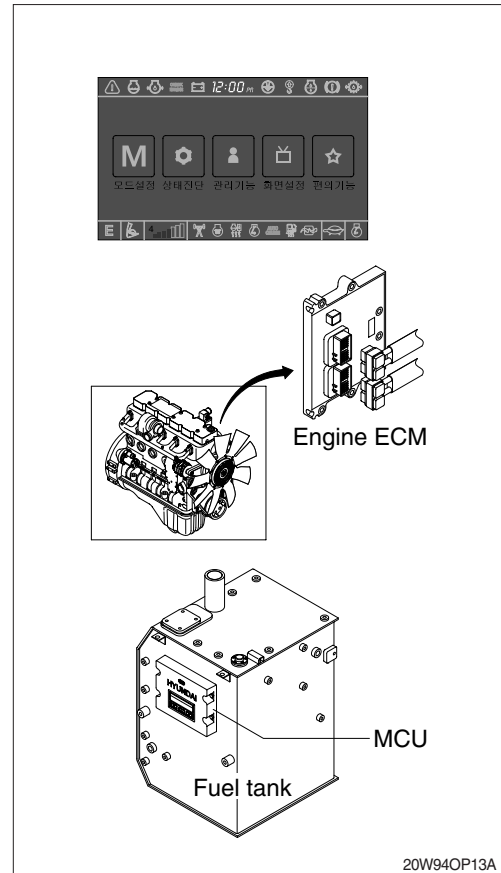

## 2) HOW TO OPERATE MODE SELECTION SYSTEM

### (1) When start key switch is turned ON

- ① When start key switch is turned on, the cluster turns on and buzzer sounds for 4 seconds. And then main information as gauges and engine speed are displayed on LCD.
- ② Initial default mode settings are displayed in the cluster.

Mode		Status
Power mode	E	ON
Work mode		ON
Travel mode	Low (	ON
Auto idle		ON

※ These setting can be changed at U mode.

- ③ Self-diagnostic function can be carried out from this point.

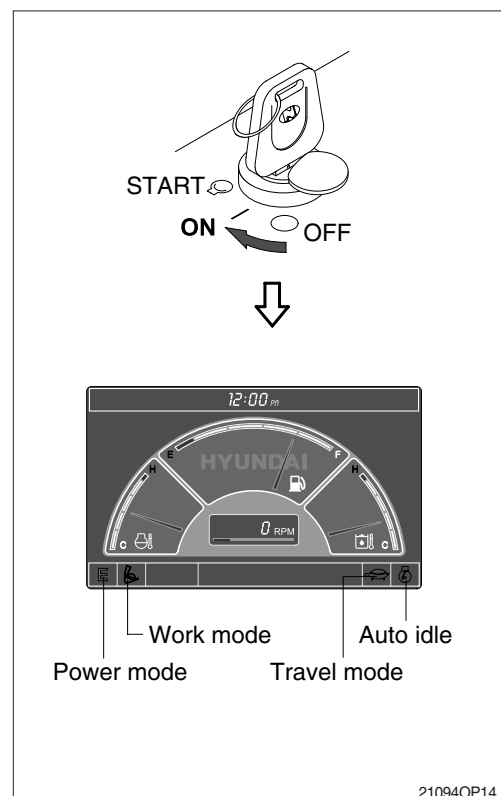

## (2) After engine start

- ① When the engine is started, rpm display indicates low idle,  $850 \pm 100$  rpm.
- ② If coolant temperature is below  $30^{\circ}\text{C}$ , the warming up pilot lamp lights ON and after 4 seconds the engine speed increases to  $1200 \pm 100$  rpm automatically to warm up the machine.
  - After 2-3 minutes, you can select any mode depending on job requirement.

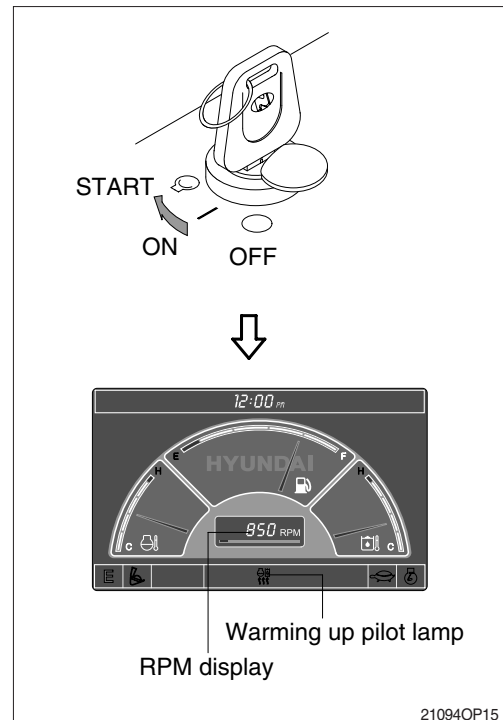

## 3) SELECTION OF POWER MODE

### (1) E mode

The accel dial is set 10 and the auto idle mode is canceled.

Engine rpm	Effect
$1350 \pm 50$	Variable power control in proportion to lever stroke (improvement in fuel efficiency) * Same power as S mode in full lever operation.

- \* When the accel dial is located below 9 the engine speed decreases about 50~100 rpm per dial set.

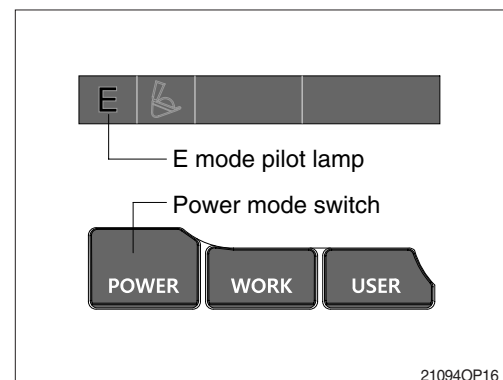

### (2) S mode

The accel dial is set 10 and the auto idle mode is canceled.

Engine rpm	Effect
$1500 \pm 50$	Standard power

- \* When the accel dial is located below 9 the engine speed decreases about 50~100 rpm per dial set.

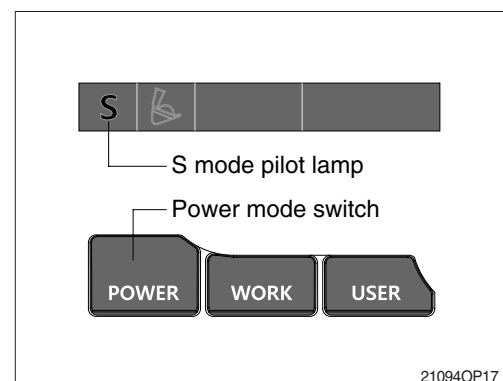

### (3) P mode

The accel dial is set 10 and the auto idle mode is canceled.

Engine rpm	Effect
1700 ± 50	Approximately 120 % of power and speed available than S mode.

※ When the accel dial is located below 9 the engine speed decreases about 50~100 rpm per dial set.

