

SPECIFICATIONS

1. MAJOR COMPONENTS

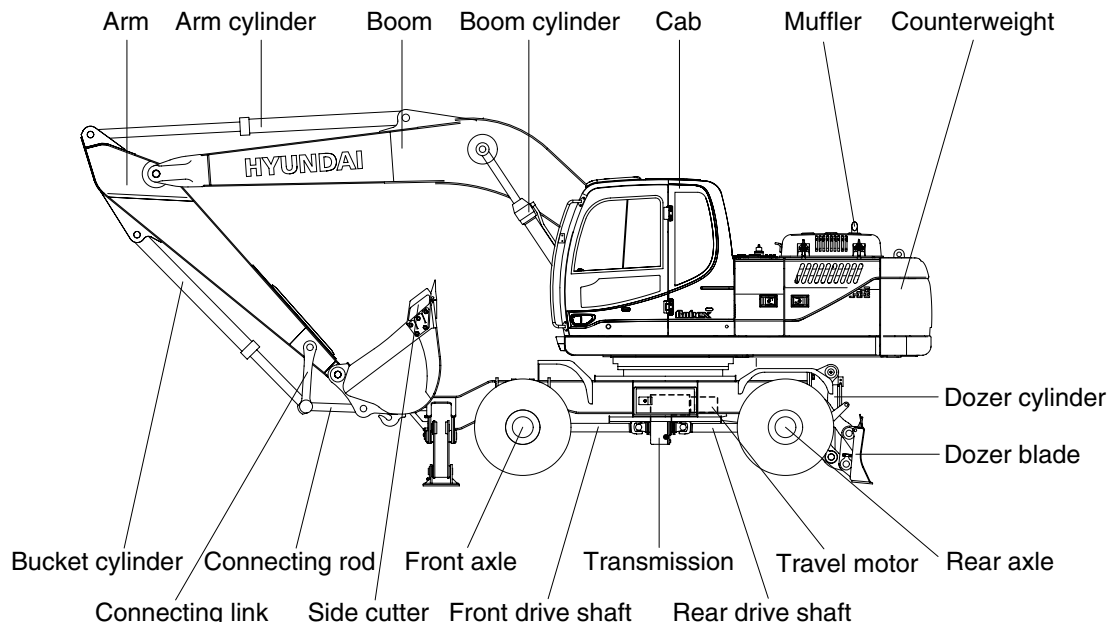
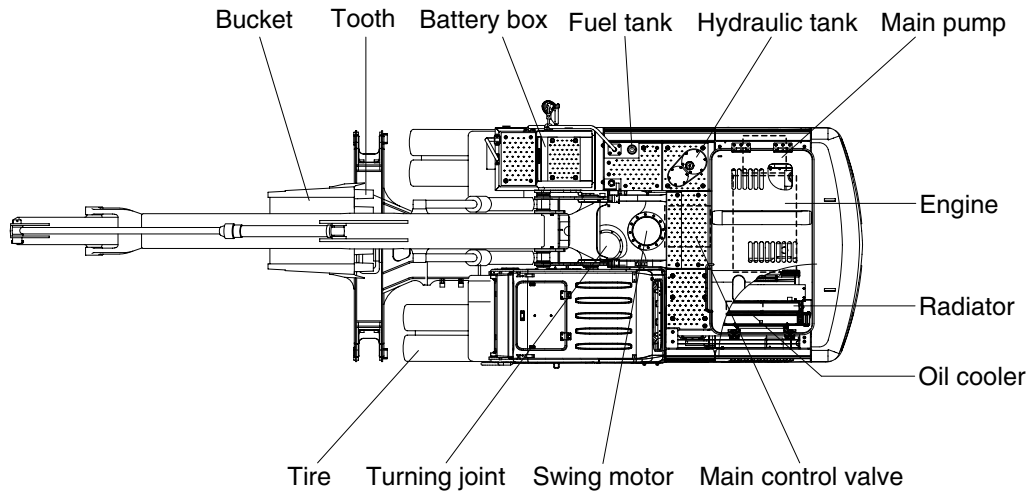

20W92SP01