

5. MAINTENANCE CHART

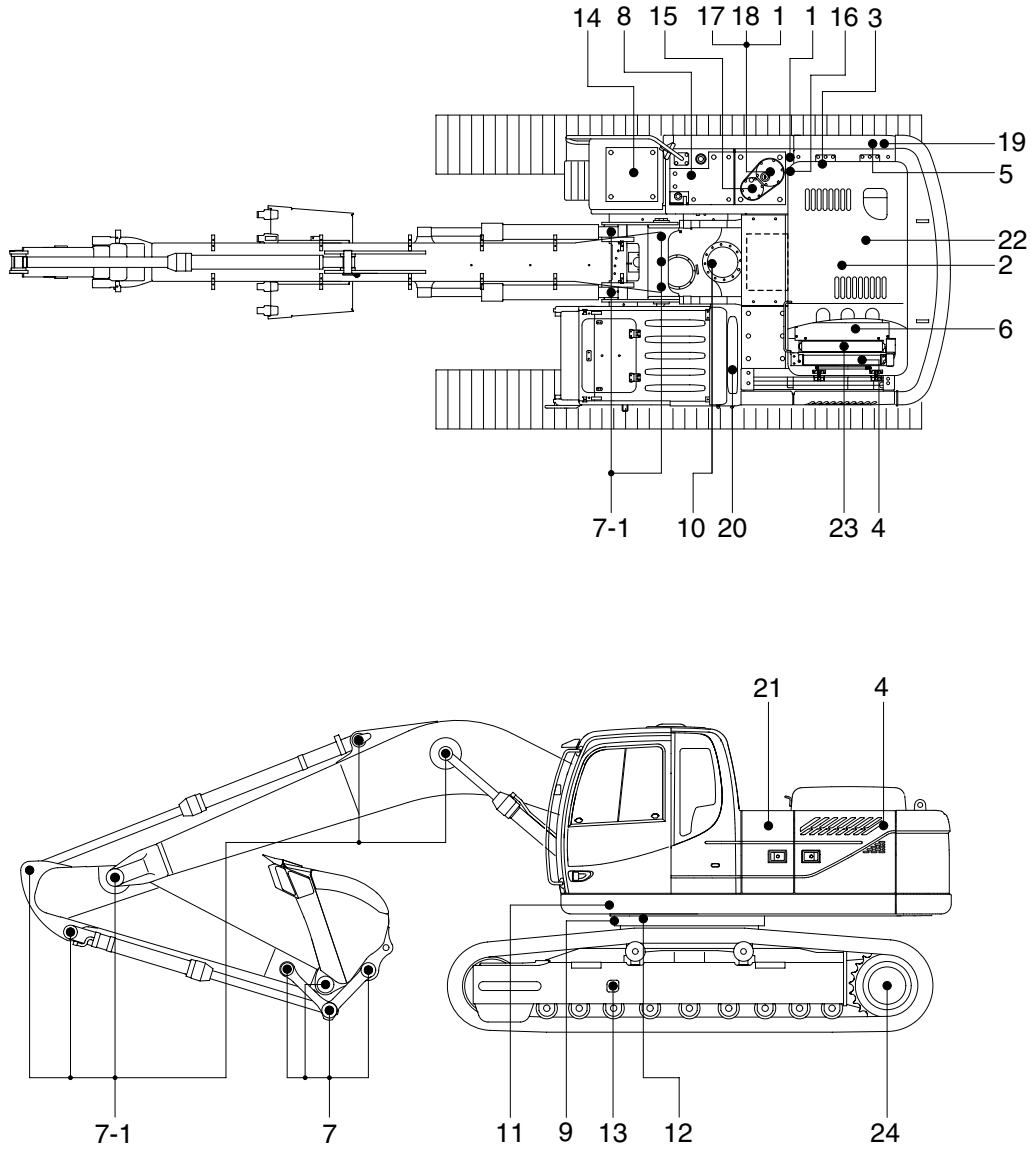

210N96MA05

Caution

1. Service intervals are based on the hour meter reading.
2. The number of each item shows the lubrication point on the machine.
3. Stop engine while filling oil, and use no open flames.

Service interval	No.	Description	Service action	Oil symbol	Capacity / (U.S.gal)	Service points No.
10 Hours or daily	1	Hydraulic oil level	Check, Add	HO	165 (43.6)	1
	2	Engine oil level	Check, Add	EO	24 (6.3)	1
	4	Radiator coolant	Check, Add	C	35 (9.2)	1
	5	Prefilter (water, element)	Check, Clean	-	-	1
	6	Fan belt tension and damage	Check, Adjust	-	-	1
	8	Fuel tank	Check, Refill	DF	310 (81.9)	1
50 Hours or weekly	7	Attachment pins & bushing	Check, Add	PGL	-	5
	8	Fuel tank (water, sediment)	Check, Clean	-	-	1
	9	Swing bearing grease	Check, Add	PGL	-	3
	10	Swing reduction gear case	Check, Add	GO	5.0 (1.3)	1
	13	Track tension	Check, Adjust	PGL	-	2
250 Hours	7-1	Attachment pins & bushing	Check, Add	PGL	-	12
	14	Battery (voltage)	Check, Clean	-	-	1
	17	Air breather element	Replace	-	-	1
	20	Aircon and heater fresh air filter	Check, Clean	-	-	1
500 Hours	2	Engine oil	Change	EO	24 (6.3)	1
	3	Engine oil filter	Replace	-	-	1
	5	Prefilter	Replace	-	-	1
	21	Air cleaner element (primary)	Check, Clean	-	-	1
	22	Fuel filter element	Replace	-	-	1
	23	Radiator, oil cooler, charge air cooler	Check, Clean	-	-	3
1000 Hours	10	Swing reduction gear case	Change	GO	5.0 (1.3)	1
	12	Swing gear and pinion grease	Change	PGL	11.7 kg (25.8 lb)	1
	15	Hydraulic oil return filter	Replace	-	-	1
	16	Drain filter cartridge	Replace	-	-	1
	19	Pilot line filter element	Replace	-	-	1
	24	Travel reduction gear case	Change	GO	5.8 (1.5)	2
2000 Hours	1	Hydraulic oil * ¹	Change	HO	165 (43.6)	1
	4	Radiator coolant	Change	C	35 (9.2)	1
	18	Hydraulic oil suction strainer	Check, Clean	-	-	1
5000 Hours	1	Hydraulic oil * ²	Change	HO	165 (43.6)	1
As required	20	Aircon & heater fresh filter	Replace	-	-	1
	20	Aircon & heater recirculation filter	Clean, Replace	-	-	1
	21	Air cleaner element (primary, safety)	Replace	-	-	2

*¹ Conventional hydraulic oil *² Hyundai genuine long life hydraulic oil

※ Oil symbol

Please refer to the recommended lubricants for specification.

DF : Diesel fuel GO : Gear oil HO : Hydraulic oil
C : Coolant PGL : Grease EO : Engine oil