

1. INSTRUCTION

1) INTERVAL OF MAINTENANCE

- (1) You may inspect and service the machine by the period as described at page 6-11 based on hour meter at control panel.
- (2) Shorten the interval of inspect and service depending on site condition. (such as dusty area, quarry, sea shore and etc.)
- (3) Practice the entire related details at the same time when the service interval is doubled.
For example, in case of 100hours, carry out all the maintenance 「Each 100hours, each 50 hours and daily service」 at the same time.

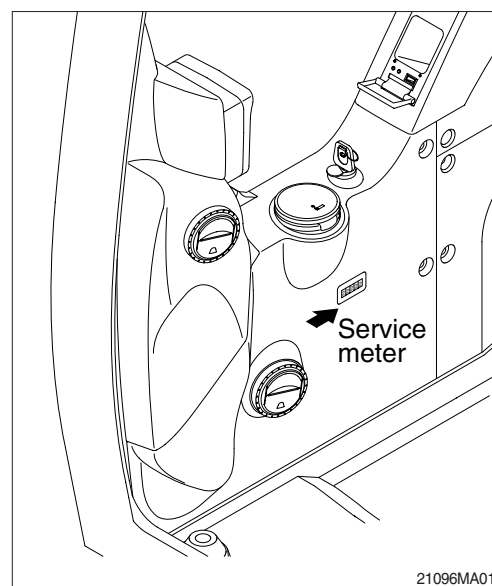

2) PRECAUTION

- (1) Start to maintenance after you have the full knowledge of machine.
- (2) The monitor installed on this machine does not entirely guarantee the condition of the machine.
Daily inspection should be performed according to clause 4, maintenance check list.
- (3) Engine and hydraulic components have been preset in the factory.
Do not allow unauthorized personnel to reset them.
- (4) Ask to your local dealer or Hyundai for the maintenance advice if unknown.
- (5) Drain the used oil and coolant in a container and handle according to the method of handling for industrial waste to meet with regulations of each province or country.

3) PROPER MAINTENANCE

(1) Replace and repair of parts

It is required to replace the wearable and consumable parts such as bucket tooth, side cutter, filter and etc., regularly.

Replace damaged or worn parts at proper time to keep the performance of machine.

- (2) Use genuine parts.
 - (3) Use the recommended oil.
 - (4) Remove the dust or water around the inlet of oil tank before supplying oil.
 - (5) Drain oil when the temperature of oil is warm.
 - (6) Do not repair anything while operating the engine.
Stop the engine when you fill the oil.
 - (7) Relieve hydraulic system of the pressure before repairing the hydraulic system.
 - (8) Confirm if the cluster is in the normal condition after completion of service.
 - (9) For more detail information of maintenance, please contact local Hyundai dealer.
- ※ **Be sure to start the maintenance after fully understand the chapter 1, safety hints.**

4) RELIEVING THE PRESSURE IN THE HYDRAULIC SYSTEM

- ※ Spouting of oil can cause the accident when loosening the cap or hose right after the operating of machine as the machine or oil is on the high pressure on the condition. Be sure to relieve the pressure in the system before repairing hydraulic system.

- (1) Place machine in parking position, and stop the engine.

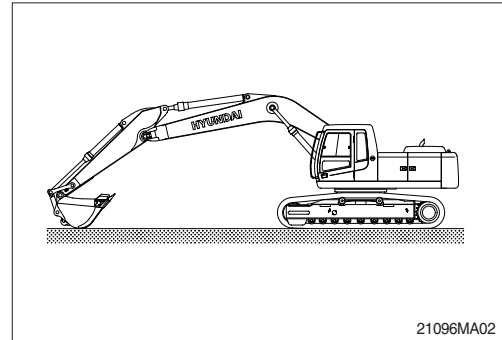

- (2) Set the safety lever completely in the release position, operate the control levers and pedals fully to the front, rear, left and right, to release the pressure in the hydraulic circuit.

- ※ **This does not completely release the pressure, so when serving hydraulic component, loosen the connections slowly and do not stand in the direction where the oil spurt out.**

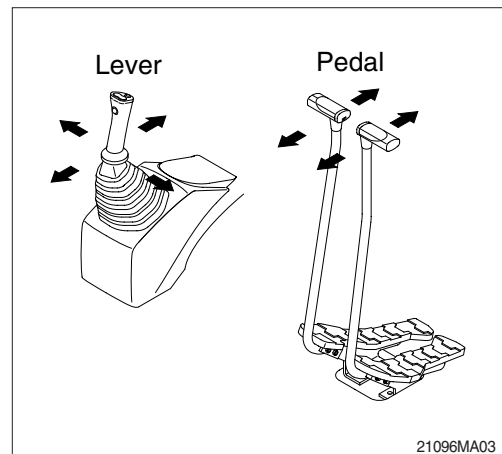

- (3) Loosen the cap and relieve the pressure in the tank by pushing the top of the air breather.

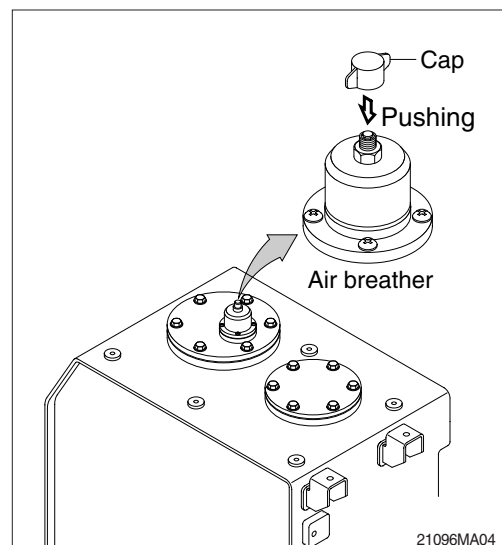

5) PRECAUTION WHEN INSTALLING HYDRAULIC HOSES OR PIPES

- (1) Be particularly careful that the joint of hose, pipe and functioning item are not damaged.
Avoid contamination.
- (2) Assemble after cleaning the hose, pipe and joint of functioning item.
- (3) Use genuine parts.
- (4) Do not assemble the hose in the condition of twisted or sharp radius.
- (5) Keep the specified tighten torque.

6) PERIODICAL REPLACEMENT OF SAFETY PARTS

(1) It is desirable to do periodic maintenance the machine for using the machine safely for a long time.

However, recommend to replace regularly the parts related safety not only safety but maintain satisfied performance.

(2) These parts can cause the disaster of life and material as the quality changes by passing time and it is worn, diluted, and gets fatigued by using repeatedly.

These are the parts which the operator can not judge the remained lifetime of them by visual inspection.

(3) Repair or replace if an abnormality of these parts is found even before the recommended replacement interval.

| Periodical replacement of safety parts | | | Interval |
|--|----------------|-----------------------------|---------------|
| Engine | | Fuel hose (tank-engine) | Every 2 years |
| | | Heater hose (heater-engine) | |
| Hydraulic system | Main circuit | Pump suction hose | Every 2 years |
| | | Pump delivery hose | |
| | | Swing hose | |
| | Working device | Boom cylinder line hose | Every 2 years |
| | | Arm cylinder line hose | |
| | | Bucket cylinder line hose | |

※ 1. Replace O-ring and gasket at the same time when replacing the hose.

2. Replace clamp at the same time if the hose clamp is cracked when checking and replacing the hose.