

7. EFFICIENT WORKING METHOD

- 1) Do the digging work by arm.

Use the pulling force of arm for digging and use together with the digging force of the bucket if necessary.

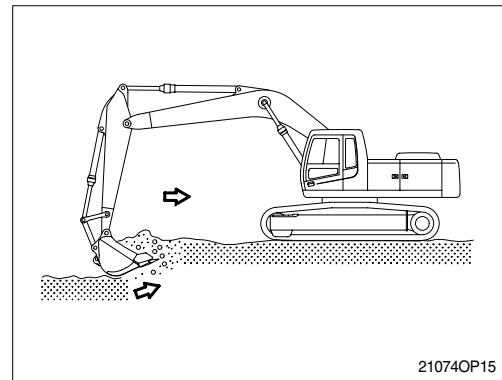

- 2) When lowering and raising the boom operate softly for the beginning and the end.

In particularly, sudden stops while lowering the boom may cause damage to the machine.

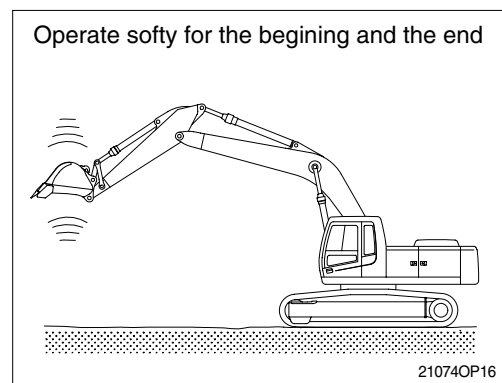

- 3) The digging resistance and wearing of tooth can be reduced by putting the end of bucket tooth to the digging direction.

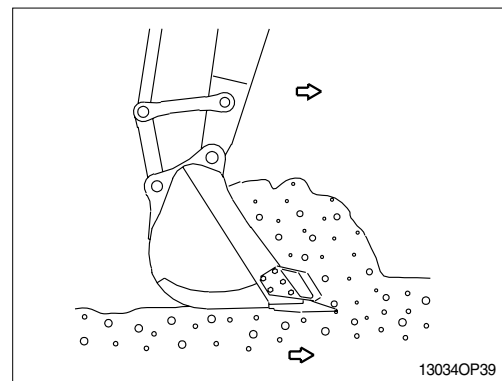

- 4) Set the tracks parallel to the line of the ditch to be excavated when digging ditch. Do not swing while digging.

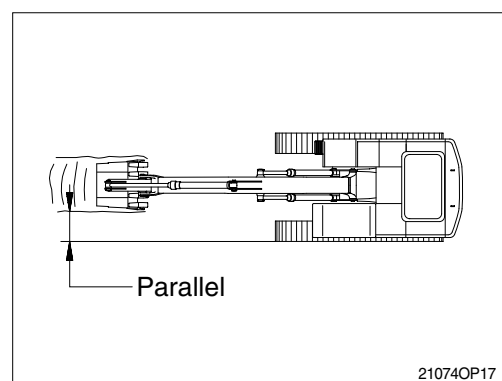

- 5) Dig slowly with keeping the angle of boom and arm, 90-110 degree when maximum digging force is required.

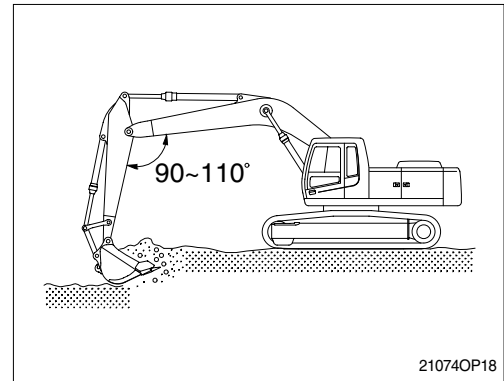

- 6) Operate leaving a small safety margin of cylinder stroke to prevent damage of cylinder when working with the machine.

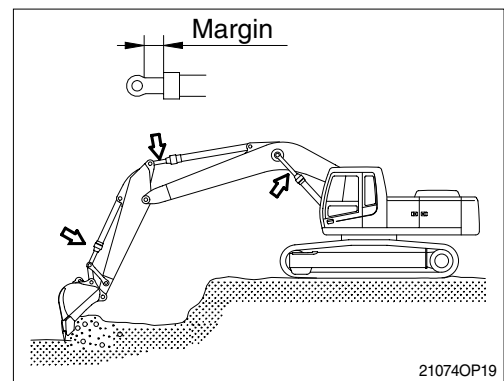

- 7) Keep the bucket to the dumping position and the arm horizontal when dumping the soil from the bucket.
Operate bucket lever 2 or 3 times when hard to dump.

※ Do not use the impact of bucket tooth when dumping.

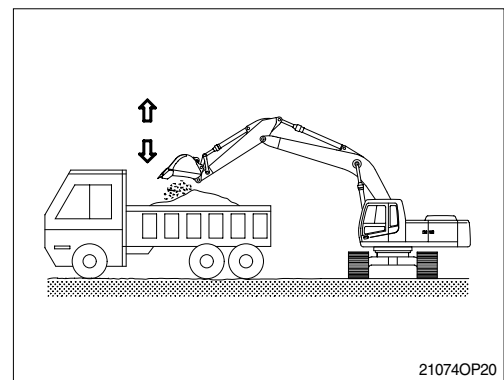

- 8) Operate stop of swing considering the swing slip distance is created by inertia after neutralizing the swing lever.

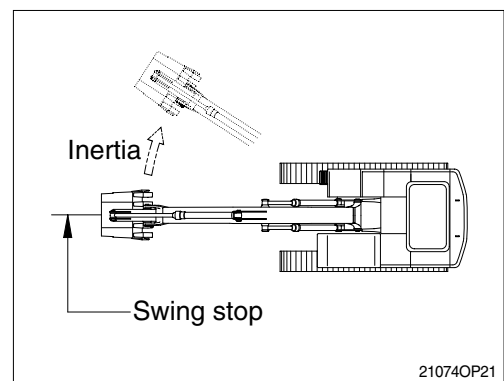

9) If the excavation is in an underground location or in a building, make sure that there is adequate overhead clearance and that there is adequate ventilation.

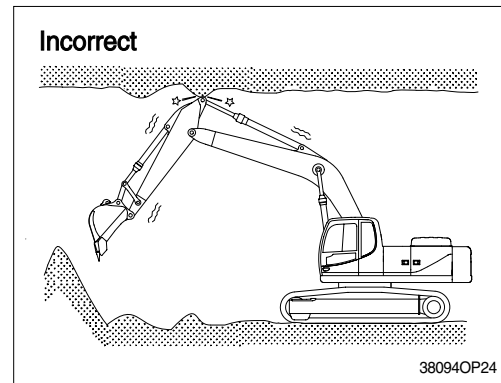

10) Do not use the dropping force of the work equipment for digging. The machine can be damaged by the impact.

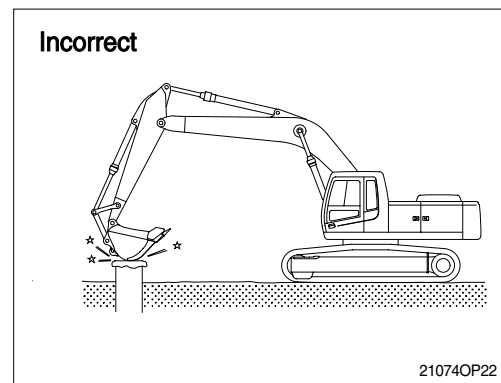

11) Do not use the bucket to crack hard objects like concrete or rocks. This may break a tooth or pin, or bend boom.

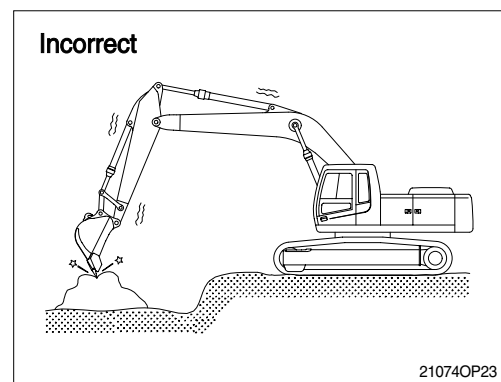

11) NEVER CARRY OUT EXCESSIVE OPERATIONS

Operation exceeding machine performance may result in accident or failure.

Carry out lifting operation within specified load limit.

Never carry out operations which may damage the machine such as overload or over-impact-load.

Never travel while carrying a load.

In case you need installing over load warning device for object handling procedure, please contact Hyundai distributor.

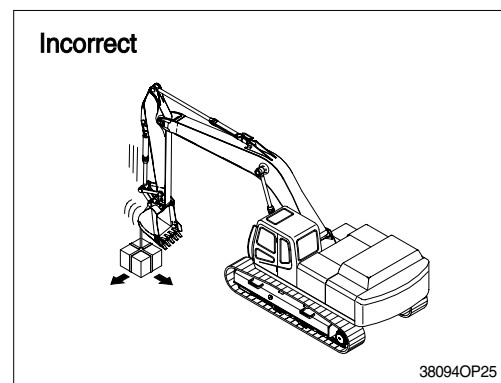

12) BUCKET WITH HOOK

When carrying out lifting work, the special lifting hook is necessary.

The following operations are prohibited.

- Lifting loads with a wire rope fitted around the bucket teeth.
- Lifting loads with the wire rope wrapped directly around the boom or arm.

When performing lifting operation, securely hook the wire rope onto the special lifting hook.

When performing lifting operation, never raise or lower a person.

Due to the possible danger of the load falling or of collision with the load, no persons shall be allowed in the working area.

Before performing lifting operation, designate an operation supervisor.

Always execute operation according to his instructions.

- Execute operating methods and procedures under his direction.
- Select a person responsible for signaling. Operate only on signals given by such person.

Never leave the operator's seat while lifting a load.

