

5. MAINTENANCE CHART

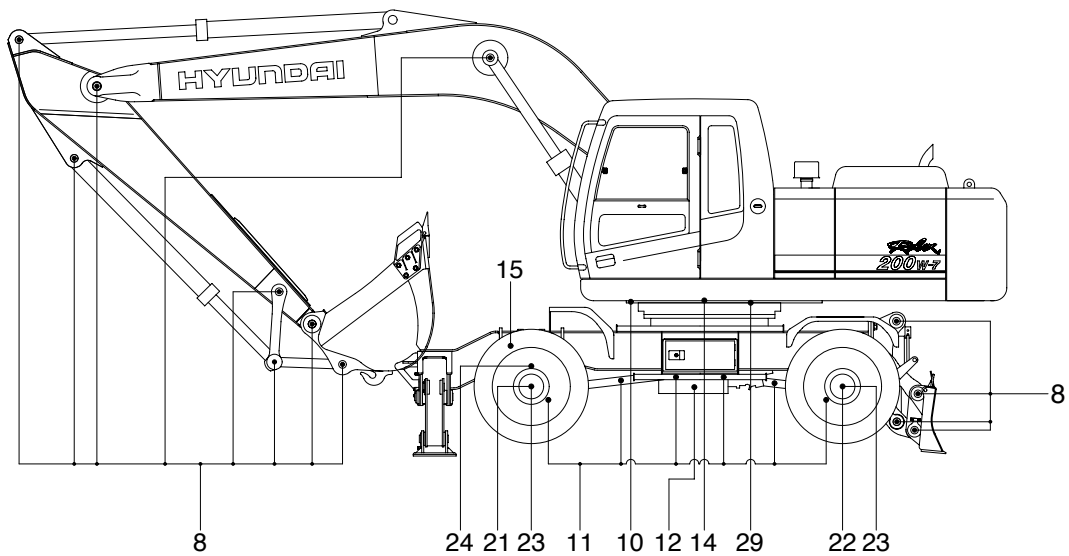
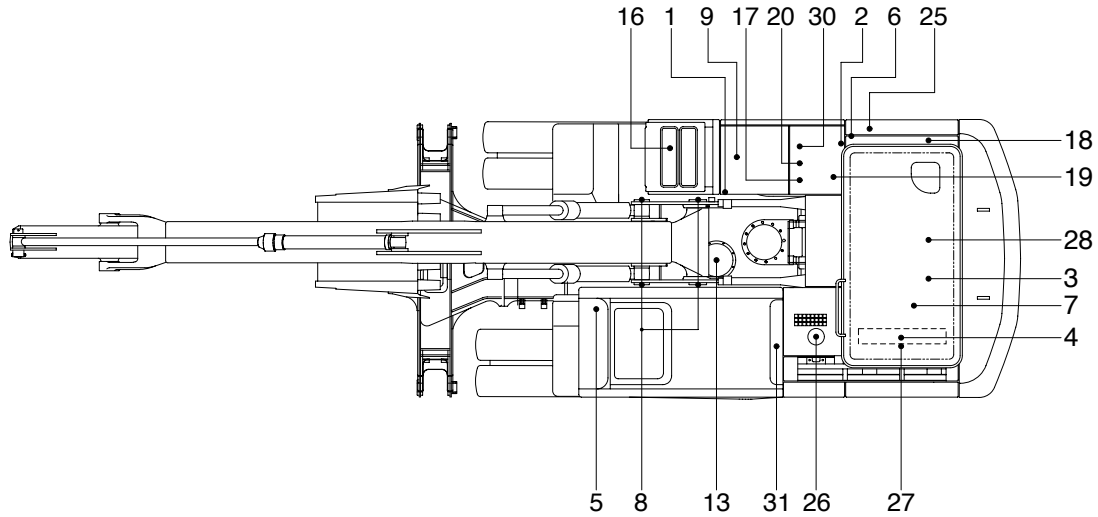

20W76MI04

Caution

1. Service intervals are based on the hour meter reading.
2. The number of each item shows the lubrication point on the machine.
3. Stop engine while filling oil, and use no open flames.
4. For other details, refer to the service manual.

Service interval	No.	Description	Service action	Oil symbol	Capacity l (U.S.gal)	Service points No.
10Hours or daily	1	Fuel tank	Check, Refill	DF	320(84.5)	1
	2	Hydraulic oil level	Check, Add	HO	180(47.6)	1
	3	Engine oil level	Check, Add	EO	14.2(3.8)	1
	4	Radiator coolant level	Check, Add	C	35(9.2)	1
	5	Control panel and pilot lamp	Check, Clean	-	-	1
	6	Water separator	Check, Drain	-	-	1
50 Hours or weekly	8	Attachment pins	Check, Add	PGL	-	17
	9	Fuel tank strainer and drain	Check, Clean	-	-	1
	10	Swing bearing grease	Check, Add	PGL	-	3
	11	Drive shaft(joint)	Check, Add	PGL	-	6
	12	Transmission case	Check, Add	EO	-	1
	13	Swing reduction gear case	Check, Add	GO	5.0(1.3)	1
	14	Swing reduction gear grease	Check, Add	PGL	1.2(0.3)	1
	15	Front axle pivot pin bushing	Check, Add	-	-	1
	32	Wheel nut	Check, Tighten	-	-	40
250 Hours	3	Engine oil level	Change	EO	14.2(3.8)	1
	16	Battery(Electrolyte, Voltage)	Check	-	-	1
	17	Hydraulic oil return filter	Replace	-	-	1
	18	Pilot line filter element	Replace	-	-	1
	19	Drain filter cartridge	Replace	-	-	1
	20	Air breather element	Replace	-	-	1
	21	Front axle differential gear case	Check, Add	GO	12.0(3.2)	1
	22	Rear axle differential gear case	Check, Add	GO	12.0(3.2)	1
	23	Axle planetary gear case(Front, rear)	Check, Add	GO	2.0(0.5)	4
	24	Front axle steering case	Check, Add	PGL	-	2
	25	Engine oil filter	Replace	-	-	1
	31	Air con and heater outer filter	Check, Clean	-	-	1
500 Hours	26	Air cleaner element(Primary)	Check, Clean	-	-	1
	27	Radiator and cooler fin, Charge air cooler	Check, Clean	-	-	3
	28	Fuel filter element	Replace	-	-	1
1000 Hours	12	Transmission case	Change	EO	3.2(0.85)	1
	13	Swing reduction gear case	Change	GO	5.0(1.3)	1
	21	Front axle differential gear case	Change	GO	12.0(3.2)	1
	22	Rear axle differential gear case	Change	GO	12.0(3.2)	1
	23	Axle planetary gear case(Front, rear)	Change	GO	2.0(0.5)	4
	29	Swing gear and pinion	Change	PGL	6.9(1.8)	1
2000 Hours	2	Hydraulic oil	Change	HO	180(47.6)	1
	4	Radiator coolant	Change	C	35(9.2)	1
	30	Hydraulic oil suction strainer	Check, Clean	-	-	1
As required	26	Air cleaner element(Primary, Safety)	Check, Replace	-	-	2
	31	Air con and heater outer filter	Replace	-	-	1
	31	Air con and heater outer filter	Check, Clean	-	-	1

★ Severely dusty area operation only.

※ Oil symbol

Please refer the recommended lubricants for specification.

DF : Diesel fuel GO : Gear oil HO : Hydraulic oil

C : Coolant PGL : Grease EO : Engine oil