

5. FIXING THE MACHINE

- 1) Place the swing lock device on the LOCK position.
- 2) Place the parking switch to the parking position.
- 3) Keep the safety lever on the SAFETY position.
- 4) Turn OFF all the switches and remove the key.

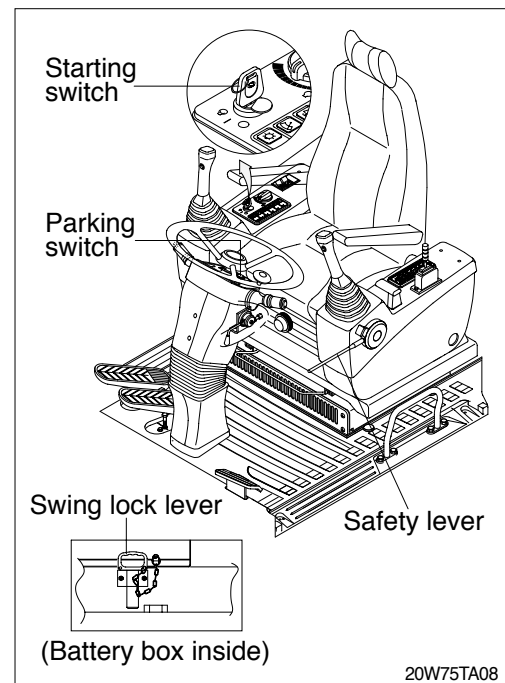

- 5) Secure all locks.

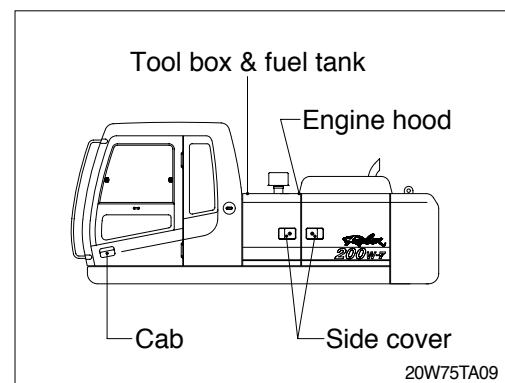

- 6) Place timber underneath of the tires and fix firmly with wire rope to prevent the machine from moving forward, backward, right or left.

