

3. DIMENSION AND WEIGHT

1) ROBEX 200W-7

(1) Base machine

Mark	Description	Unit	Specification
L	Length	mm(ft-in)	5220(17' 2")
H	Height	mm(ft-in)	3190(10' 6")
W	Width	mm(ft-in)	2495(8' 2")
Wt	Weight	kg(lb)	16200(35720)

3400kg(7500lb) counterweight.

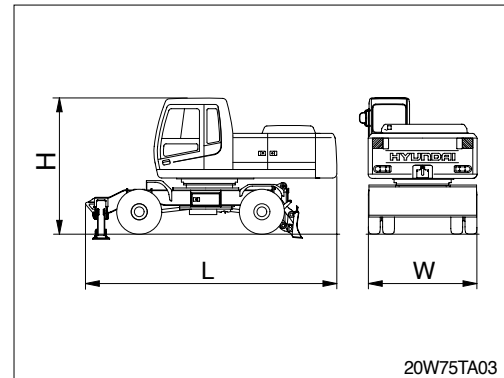

(2) Boom assembly

Mark	Description	Unit	Specification
L	Length	mm(ft-in)	5840(19' 2")
H	Height	mm(ft-in)	1550(5' 1")
W	Width	mm(ft-in)	630(2' 1")
Wt	Weight	kg(lb)	1870(4120)

5.65m(18' 6") boom with arm cylinder(Included piping and pins).

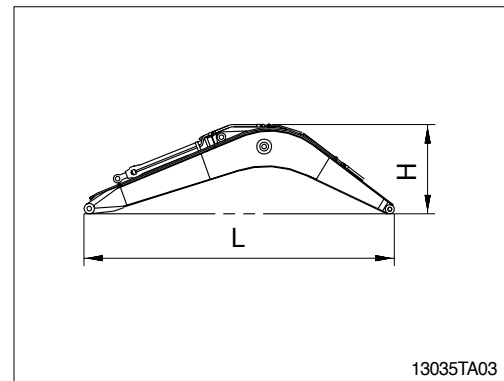

(3) Arm assembly

Mark	Description	Unit	Specification
L	Length	mm(ft-in)	3900(12'10")
H	Height	mm(ft-in)	870(2' 10")
W	Width	mm(ft-in)	350(1' 2")
Wt	Weight	kg(lb)	1040(2290)

2.90m(9' 6") arm with bucket cylinder(Included linkage and pins).

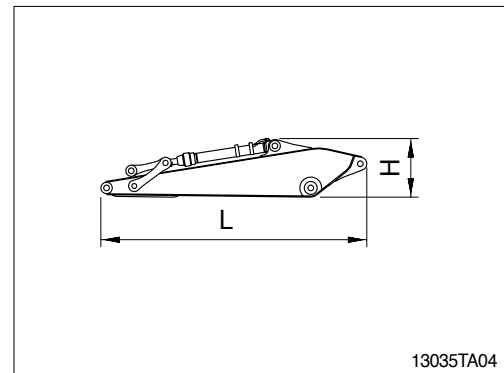

(4) Bucket assembly

Mark	Description	Unit	Specification
L	Length	mm(ft-in)	1600(5' 3")
H	Height	mm(ft-in)	980(3' 3")
W	Width	mm(ft-in)	1160(3' 10")
Wt	Weight	kg(lb)	650(1430)

0.80m³(1.05yd³) SAE heaped bucket(Included tooth and side cutters).

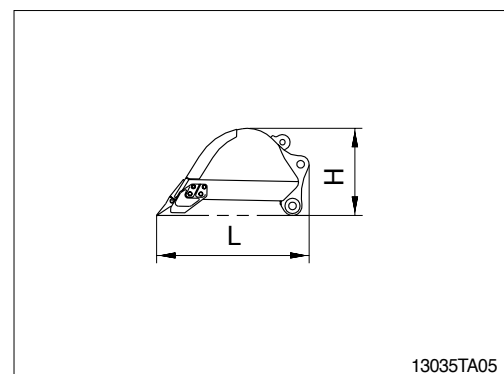

(5) Boom cylinder

Mark	Description	Unit	Specification
L	Length	mm(ft-in)	1960(6' 5")
H	Height	mm(ft-in)	230(0' 9")
W	Width	mm(ft-in)	330(1' 1")
Wt	Weight(2EA)	kg(lb)	380(840)

Included piping.

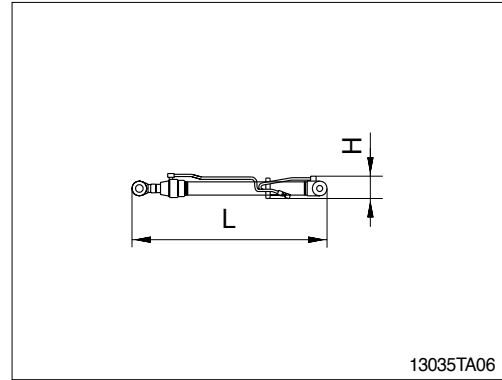

13035TA06

(6) Cab assembly

Mark	Description	Unit	Specification
L	Length	mm(ft-in)	1962(6' 4")
H	Height	mm(ft-in)	1676(5' 5")
W	Width	mm(ft-in)	1288(4' 2")
Wt	Weight	kg(lb)	310(680)

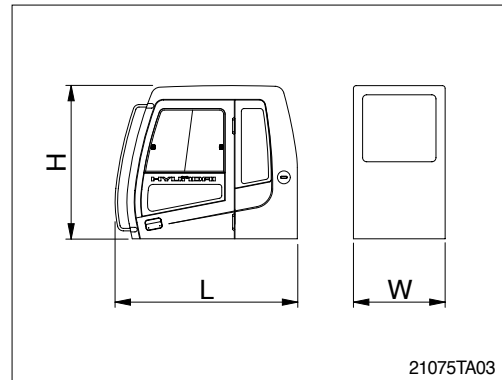

21075TA03

(7) Counterweight

Mark	Description	Unit	Specification
L	Length	mm(ft-in)	2700(8' 10")
H	Height	mm(ft-in)	1050(3' 5")
W	Width	mm(ft-in)	560(1' 10")
Wt	Weight	kg(lb)	3400(7500)

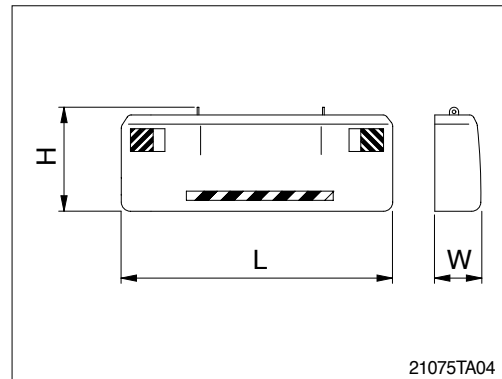

21075TA04