

5. MAINTENANCE CHART

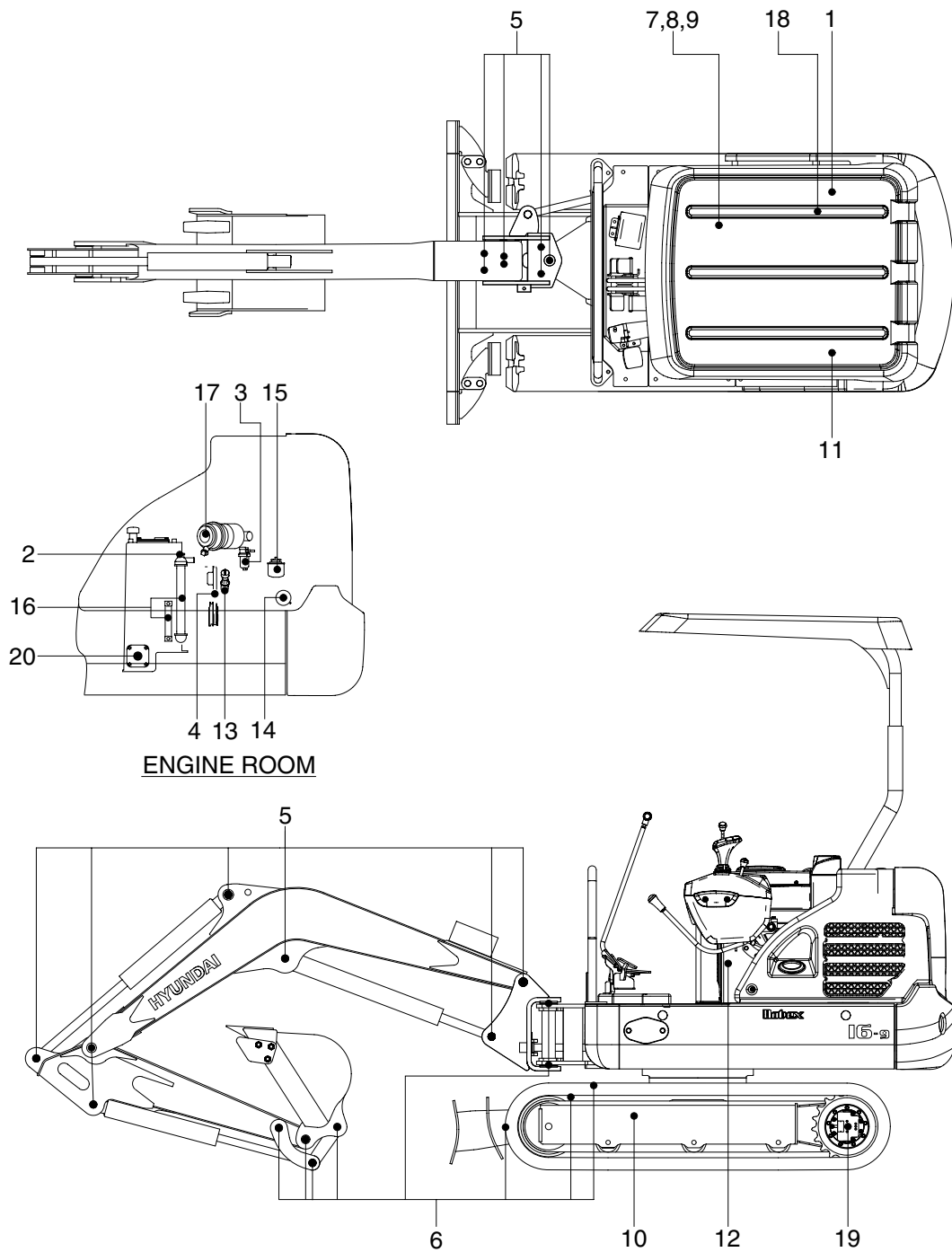

1696MA16

Caution

1. Service intervals are based on the hour meter reading.
2. The number of each item shows the lubrication point on the machine.
3. Stop engine while filling oil, and use no open flames.
4. For other details, refer to the service manual.

| Service interval | No. | Description | Service action | Oil symbol | Capacity / (U.S.gal) | Service points No. |
|--------------------|-----|--------------------------------------|----------------|------------|----------------------|--------------------|
| 10 Hours or daily | 1 | Hydraulic oil level | Check, Add | HO | 20 (5.3) | 1 |
| | 2 | Radiator coolant | Check, Add | C | 5 (1.3) | 1 |
| | 3 | Water separator | Drain | - | - | 1 |
| | 4 | Fan belt tension and damage | Check, Adjust | - | - | 1 |
| | 13 | Engine oil level | Check, Add | EO | 4.2 (1.1) | 1 |
| 50 Hours or weekly | 6 | Bucket linkage & blade pins | Check, Add | PGL | - | 6 |
| | 7 | Boom swing cylinder | Lubricate | PGL | - | 1 |
| | 8 | Swing bearing | Lubricate | PGL | - | 1 |
| | 9 | Swing ring gear and pinion | Check, Add | PGL | - | 1 |
| | 10 | Track tension | Check, Adjust | PGL | - | 2 |
| | 11 | Fuel tank (water, sediment) | Check, Clean | - | - | 1 |
| 250 Hours | 5 | Attachment pins | Check, Add | PGL | - | 9 |
| | 12 | Battery (voltage) | Check, Clean | - | - | 1 |
| | 13 | Engine oil | Change | EO | 4.2 (1.1) | 1 |
| | 14 | Engine oil filter | Replace | - | - | 1 |
| | 18 | Hydraulic oil return filter | Change | - | - | 1 |
| 400 Hours | 15 | Fuel filter element | Replace | - | - | 1 |
| 500 Hours | 16 | Radiator and cooler fin | Check, Clean | - | - | 2 |
| | 17 | Air cleaner element (outside) | Clean | - | - | 1 |
| 1000 Hours | 19 | Travel reduction gear case | Change | GO | 0.33 (0.09) | 2 |
| 2000 Hours | 1 | Hydraulic oil * ¹ | Change | HO | 20 (5.3) | 1 |
| | 2 | Radiator coolant | Change | C | 5 (1.3) | 1 |
| | 20 | Hydraulic oil suction strainer | Check, Clean | - | - | 1 |
| 5000 Hours | 1 | Hydraulic oil * ² | Change | HO | 20 (5.3) | 1 |
| As required | 17 | Air cleaner element (inside/outside) | Check, Clean | - | - | 2 |

*¹ Conventional hydraulic oil

*² Hyundai genuine long life hydraulic oil

※ Oil symbol

Please refer to the recommended lubricants for specification.

DF : Diesel fuel

GO : Gear oil

HO : Hydraulic oil

C : Coolant

PGL : Grease

EO : Engine oil