

## 1. SUGGESTION FOR NEW MACHINE

- 1) It takes about 100 operation hours to enhance its designed performance.
- 2) Operate according to below three steps and avoid excessive operation for the initial 100 hours.

Service meter	Load
Until 10 hours	About 60%
Until 100 hours	About 80%
After 100 hours	100%

※ **Excessive operation may deteriorate the potential performance of machine and shorten lifetime of the machine.**

- 3) Be careful during the initial 100 hours operation
  - (1) Check daily for the level and leakage of coolant, engine oil, hydraulic oil and fuel.
  - (2) Check regularly the lubrication and fill grease daily all lubrication points.
  - (3) Tighten bolts.
  - (4) Warm up the machine fully before operation.
  - (5) Check the gauges occasionally during the operation.
  - (6) Check if the machine is operating normally during operation.
- 4) Replace followings after initial 50 or 250 hours of operation

Checking items	Hours
Engine oil	50
Engine oil filter element	
Fuel filter	
Hydraulic oil return filter element	250

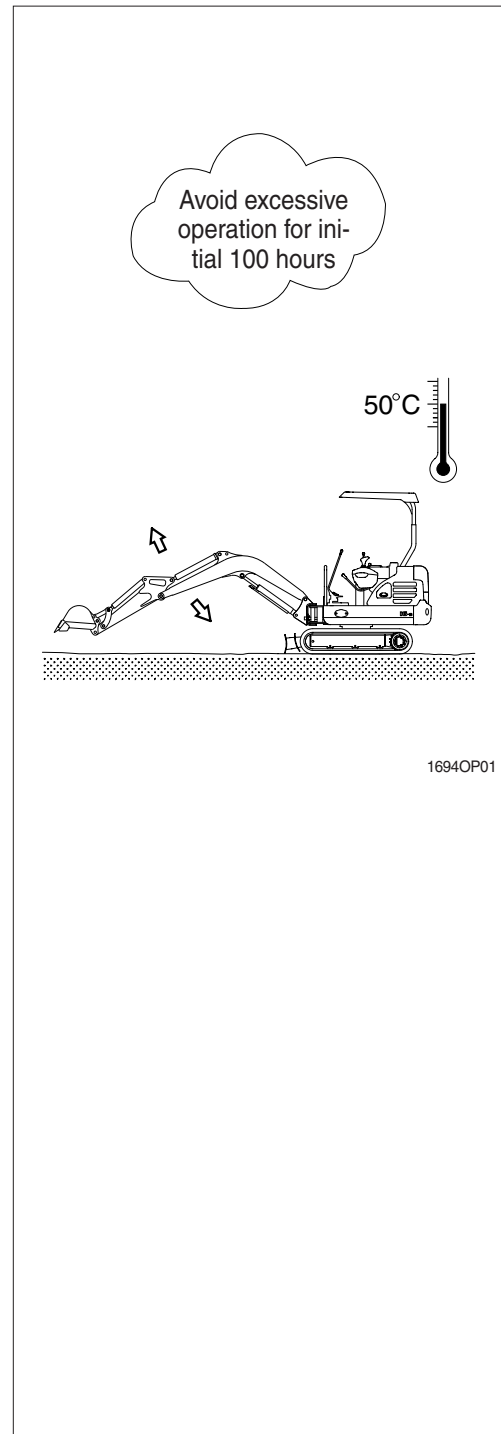

1694OP01