

SPECIFICATIONS

1. MAJOR COMPONENT

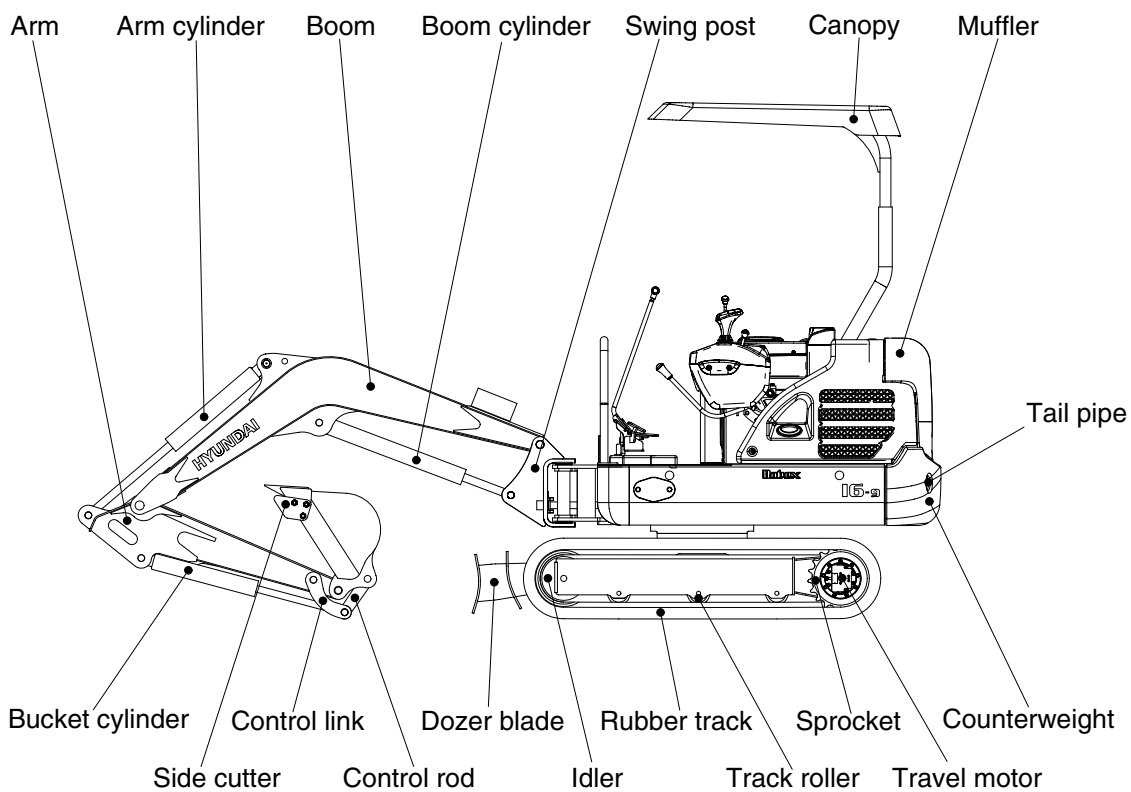
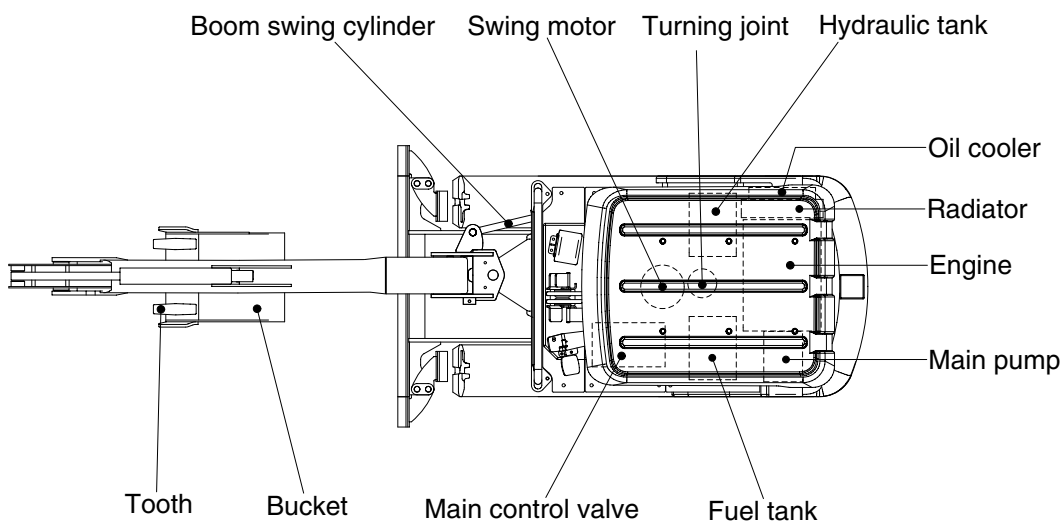

1692SP01

2. SPECIFICATIONS

1) 1.80 m (5' 11") MONO BOOM, 0.96 m (3' 2") ARM, WITH BOOM SWING POST

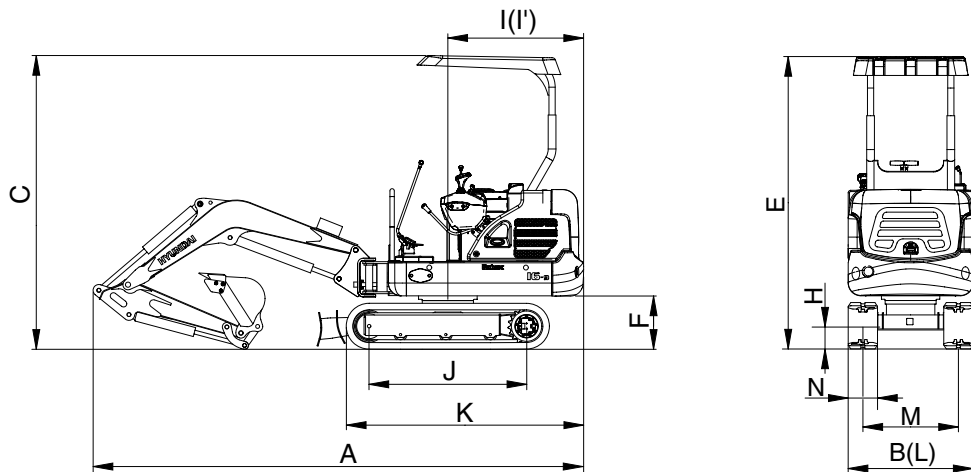

1692SP02

Description	Unit	Specification
Operating weight (canopy)	kg (lb)	1650 (3640)
Bucket capacity (SAE heaped), standard	m ³ (yd ³)	0.04 (0.05)
Overall length	A	3840 (12' 7")
Overall width, with 230 mm shoe (extension crawler)	B	980~1250 (3' 3" ~ 4' 1")
Overall height	C	2300 (7' 7")
Overall height of canopy	E	2300 (7' 7")
Ground clearance of counterweight	F	415 (1' 4")
Minimum ground clearance	H	150 (0' 6")
Rear-end distance	I	1065 (3' 6")
Rear-end swing radius	I'	1065 (3' 6")
Distance between tumbler rollers	J	1230 (4' 0")
Undercarriage length	K	1590 (5' 3")
Undercarriage width (extension crawler)	L	980~1250 (3' 3" ~ 4' 1")
Track gauge (extension crawler)	M	750~1020 (2' 6" ~ 3' 4")
Track shoe width, standard	N	230 (9")
Height of blade	O	250 (0' 10")
Ground clearance of blade up	P	170 (0' 7")
Depth of blade down	Q	240 (0' 9")
Travel speed (low/high)	km/hr (mph)	2.2/4.1 (1.4/2.5)
Swing speed	rpm	9.3
Gradeability	Degree (%)	30 (58)
Ground pressure 230 mm rubber shoe (canopy)	kgf/cm ² (psi)	0.27 (3.84)
Max traction force	kg (lb)	1550 (3420)

3. WORKING RANGE

1) 1.80 m (5' 11") MONO BOOM WITH BOOM SWING POST

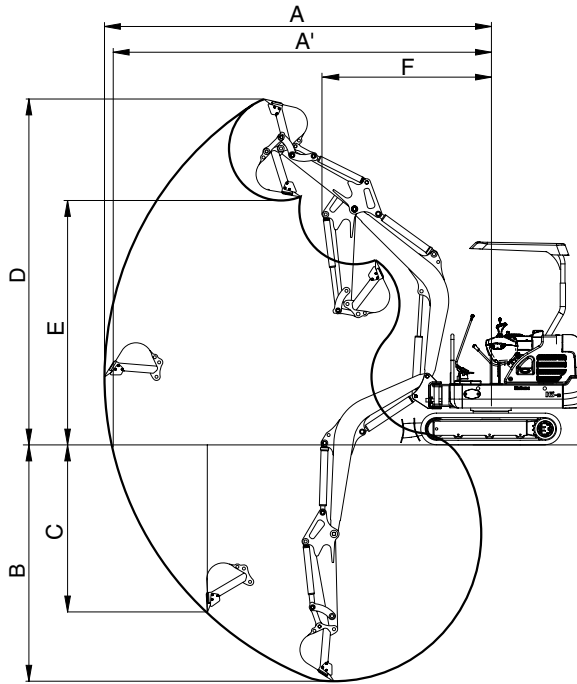

1692SP03

Description		0.96 m (3' 2") Arm	
Max digging reach	A	3970 mm (13' 0")	
Max digging reach on ground	A'	3880 mm (12' 9")	
Max digging depth	B	2250 mm (7' 5")	
Max vertical wall digging depth	C	1785 mm (5' 10")	
Max digging height	D	3670 mm (12' 0")	
Max dumping height	E	2550 mm (8' 4")	
Min swing radius	F	1615 mm (5' 4")	
Boom swing radius (left/right)		60°/60°	
Bucket digging force	SAE	13.1 kN	
		1340 kgf	
		2950 lbf	
	ISO	15.1 kN	
		1540 kgf	
		3400 lbf	
Arm crowd force	SAE	9.0 kN	
		920 kgf	
		2030 lbf	
	ISO	9.4 kN	
		960 kgf	
		2120 lbf	

4. WEIGHT









Item	kg	lb
Upperstructure assembly	1640	3615
Main frame weld assembly	230	510
Engine assembly	75	165
Main pump assembly	17	37
Main control valve assembly	25	55
Swing motor assembly	23	50
Hydraulic oil tank assembly	20	44
Fuel tank assembly	15	33
Boom swing post	35	80
Counterweight	60	130
Canopy assembly	47	104
Front guard	12	26
Lower chassis assembly	530	1170
Track frame weld assembly	150	330
Swing bearing	20	44
Travel motor assembly	18	40
Turning joint	20	44
Track recoil spring	11	24
Idler	15	33
Track roller	3	7
Sprocket	4	9
Rubber track (230 mm)	66	146
Dozer blade assembly	60	130
Front attachment assembly (1.8 m boom, 0.96 m arm, 0.04 m ³ SAE heaped bucket)	200	440
1.8 m boom assembly	65	140
0.96 m arm assembly	30	70
0.04 m ³ SAE heaped bucket	40	90
Boom cylinder assembly	17	37
Arm cylinder assembly	15	33
Bucket cylinder assembly	11	24
Bucket control link assembly	10	22
Dozer cylinder assembly	11	24
Boom swing cylinder assembly	11	24
Extension cylinder assembly	8	18

5. LIFTING CAPACITIES

1) 1.8 m (5' 11") boom, 0.96 m (3' 2") arm equipped with 0.04 m³ (SAE heaped) bucket and 230 mm (9") rubber track, the dozer blade up with 60 kg (130 lb) counterweight.

•  : Rating over-front

•  : Rating over-side or 360 degree









Load point height		Load radius						At max. reach		
		2.0 m (6.6 ft)		2.5 m (8.2 ft)		3.0 m (10.0 ft)		Capacity		Reach
										m (ft)
3.0 m (10.0 ft)	kg lb							300 660	270 600	2.72 (8.9)
2.5 m (8.2 ft)	kg lb			340 750	310 680			220 490	200 440	3.22 (10.6)
2.0 m (6.6 ft)	kg lb			330 730	300 660	240 530	220 490	180 400	170 370	3.52 (11.5)
1.5 m (5.0 ft)	kg lb	470 1040	420 930	320 710	290 640	240 530	220 490	170 370	150 330	3.69 (12.1)
1.0 m (3.3 ft)	kg lb	450 990	400 880	310 680	280 620	230 510	210 460	160 350	140 310	3.76 (12.3)
0.5 m (1.6 ft)	kg lb	420 930	380 840	300 660	270 600	220 490	200 440	160 350	140 310	3.74 (12.3)
Ground Line	kg lb	410 900	370 820	290 640	260 570	220 490	200 440	160 350	150 330	3.62 (11.9)
-0.5 m (-1.6 ft)	kg lb	410 900	360 790	290 640	260 570	220 490	200 440	180 400	170 370	3.39 (11.1)
-1.0 m (-3.3 ft)	kg lb	410 900	370 820	290 640	260 570			230 510	200 440	3.00 (9.8)
-1.5 m (-5.0 ft)	kg lb	430 950	380 840							
-2.5 m (-8.2 ft)	kg lb							230 510	210 460	3.14 (10.3)

- Note
1. Lifting capacity are based on SAE J1097 and ISO 10567.
 2. Lifting capacity of the ROBEX series does not exceed 75% of tipping load with the machine on firm, level ground or 87% of full hydraulic capacity.
 3. The load point is a hook located on the back of the bucket.

2) 1.8 m (5' 11") boom, 0.96 m (3' 2") arm equipped with 0.04 m³ (SAE heaped) bucket and 230 mm (9") rubber track, the dozer blade down with 60 kg (130 lb) counterweight.

•  : Rating over-front

•  : Rating over-side or 360 degree

Load point height		Load radius						At max. reach		
		2.0 m (6.6 ft)		2.5 m (8.2 ft)		3.0 m (10.0 ft)		Capacity		Reach
										m (ft)
3.0 m (10.0 ft)	kg lb							*480 *1060	290 640	2.72 (8.9)
2.5 m (8.2 ft)	kg lb			*490 *1080	320 710			*430 *950	210 460	3.22 (10.6)
2.0 m (6.6 ft)	kg lb			*610 *1340	320 710	*410 *900	230 510	*410 *900	180 400	3.52 (11.5)
1.5 m (5.0 ft)	kg lb	*970 *2140	450 990	790 1740	310 680	560 1230	230 510	390 860	160 350	3.69 (12.1)
1.0 m (3.3 ft)	kg lb	1210 2670	420 930	770 1700	300 660	560 1230	220 490	380 840	150 330	3.76 (12.3)
0.5 m (1.6 ft)	kg lb	1180 2600	400 880	760 1680	290 640	550 1210	220 490	380 840	150 330	3.74 (12.3)
Ground Line	kg lb	1170 2580	390 860	750 1650	280 620	540 1190	210 460	400 880	160 350	3.62 (11.9)
-0.5 m (-1.6 ft)	kg lb	1160 2560	390 860	740 1630	280 620	540 1190	210 460	450 990	180 400	3.39 (11.1)
-1.0 m (-3.3 ft)	kg lb	1170 2580	390 860	750 1650	280 620			550 1210	220 490	3.00 (9.8)
-1.5 m (-5.0 ft)	kg lb	1180 2600	400 880							
-2.5 m (-8.2 ft)	kg lb							*480 *1060	220 490	3.14 (10.3)

- Note
1. Lifting capacity are based on SAE J1097 and ISO 10567.
 2. Lifting capacity of the ROBEX series does not exceed 75% of tipping load with the machine on firm, level ground or 87% of full hydraulic capacity.
 3. The load point is a hook located on the back of the bucket.
 4. *indicates load limited by hydraulic capacity.

6. BUCKET SELECTION GUIDE

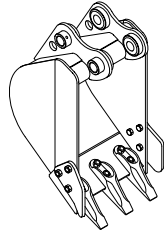

0.04 m³ SAE
heaped bucket

Capacity		Width		Weight	Recommendation
SAE heaped	CECE heaped	Without side cutter	With side cutter		1.8 m (5' 11") boom
					0.96 m (3' 2") arm
0.04m ³ (0.05 yd ³)	0.03 m ³ (0.04 yd ³)	390 mm (15.4")	440 mm (17.3")	40 kg (88 lb)	Applicable for materials with density of 1600 kgf/m ³ (2700 lb /yd ³) or less

7. UNDERCARRIAGE

(1) TRACKS

X-leg type center frame is integrally welded with reinforced box-section track frames. The design includes dry tracks, lubricated rollers, idlers, sprockets, hydraulic track adjusters with shock absorbing springs and assembled track-type tractor shoes with triple grousers.

(2) TYPES OF SHOES

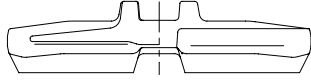
Model	Shapes		Rubber track
			
R16-9	Shoe width	mm (in)	230 (9")
	Operating weight	kg (lb)	1650 (3640)
	Ground pressure	kgf/cm ² (psi)	0.27 (3.84)
	Overall width	mm (ft-in)	1250 (4' 1")

(3) NUMBER OF ROLLERS AND SHOES ON EACH SIDE

Item	Quantity
Track rollers	3 EA

8. SPECIFICATIONS FOR MAJOR COMPONENTS

1) ENGINE

Item	Specification
Model	Mitsubishi L3E
Type	4-cycle vertical overhead valve, diesel fuel
Cooling method	Water cooling
Number of cylinders and arrangement	3 cylinders, in-line
Firing order	1-3-2
Combustion chamber type	Swirl chamber type
Cylinder bore × stroke	76 × 70 mm (2.99" × 2.76")
Piston displacement	952 cc (58.1 cu in)
Compression ratio	23 : 1
Rated gross horse power (SAE J1995)	16.8 Hp at 2300 rpm (12.5 kW at 2300 rpm)
Maximum torque at 1600 rpm	5.4 kgf · m (39 lbf · ft)
Engine oil quantity	4.2 l (1.1 U.S. gal)
Dry weight	75 kg (165 lb)
High idling speed	2500+ 30 rpm
Low idling speed	1600 ± 25 rpm
Rated fuel consumption	208 g/Hp · hr at 2300 rpm (279 g/kW · hr at 2300 rpm)
Starting motor	12V-1.7 kW
Alternator	12V-40 A
Battery	1 × 12 V × 80 Ah

2) MAIN PUMP

Item	Specification
Type	Variable displacement tandem axis piston pumps
Capacity	2 × 7.4 cc/rev
Rated oil flow	2 × 17.0 l /min (4.5 U.S. gpm / 3.7 U.K. gpm)
Rated speed	2300 rpm

3) GEAR PUMP

Item	Specification
Type	Fixed displacement gear pump single stage
Capacity	4.5/2.7 cc/rev
Rated oil flow	10.4/6.2 l /min (2.7/1.6 U.S. gpm / 2.3/1.4 U.K. gpm)

4) MAIN CONTROL VALVE

Item	Specification
Type	Sectional, 9 spools (12 blocks)
Operating method	Hydraulic pilot system
Main relief valve pressure	210 kgf/cm ² (2990 psi)
Overload relief valve pressure	230 kgf/cm ² (3270 psi)

5) SWING MOTOR

Item	Specification
Type	Fixed displacement axial piston motor
Capacity	18.1 cc/rev
Relief pressure	165 kgf/cm ² (2350 psi)
Reduction gear type	1 - stage planetary

6) TRAVEL MOTOR

Item	Specification
Type	Variable displacement axial piston motor
Relief pressure	210 kgf/cm ² (2990 psi)
Reduction gear type	2-stage planetary

7) CYLINDER

Item		Specification
Boom cylinder	Bore dia × Rod dia × Stroke	∅ 60 × ∅ 40 × 465 mm
	Cushion	Extend only
Arm cylinder	Bore dia × Rod dia × Stroke	∅ 60 × ∅ 40 × 400 mm
	Cushion	Extend and retract
Bucket cylinder	Bore dia × Rod dia × Stroke	∅ 55 × ∅ 35 × 345 mm
	Cushion	-
Boom swing cylinder	Bore dia × Rod dia × Stroke	∅ 55 × ∅ 30 × 355 mm
	Cushion	-
Dozer cylinder	Bore dia × Rod dia × Stroke	∅ 65 × ∅ 30 × 93 mm
	Cushion	-

※ Discoloration of cylinder rod can occur when the friction reduction additive of lubrication oil spreads on the rod surface.

※ Discoloration does not cause any harmful effect on the cylinder performance.

8) BUCKET

Item	Capacity		Tooth quantity	Width	
	SAE heaped	CECE heaped		Without side cutter	With side cutter
Standard	0.04 m ³ (0.05 yd ³)	0.03 m ³ (0.04 yd ³)	3	390 mm (15.4")	440 mm (17.3")

9. RECOMMENDED OILS

Use only oils listed below or equivalent.
Do not mix different brand oil.

Service point	Kind of fluid	Capacity l (U.S. gal)	Ambient temperature °C (°F)						
			-20 (-4)	-10 (14)	0 (32)	10 (50)	20 (68)	30 (86)	40 (104)
Engine oil pan	Engine oil	4.2 (1.1)	SAE 30						
			SAE 10W						
			SAE 10W-30						
			SAE 15W-40						
Final drive	Gear oil	0.33 × 2 (0.09 × 2)	SAE 30						
Hydraulic tank	Hydraulic oil	Tank: 20 (5.3) System: 30 (7.9)	ISO VG 32						
			ISO VG 46						
			ISO VG 68						
Fuel tank	Diesel fuel	25 (6.6)	ASTM D975 NO.1						
			ASTM D975 NO.2						
Fitting (Grease nipple)	Grease	As required	NLGI NO.1						
			NLGI NO.2						
Radiator (Reservoir tank)	Mixture of antifreeze and water 50 : 50	3.5 (0.9)	Ethylene glycol base permanent type						

SAE : Society of Automotive Engineers
API : American Petroleum Institute
ISO : International Organization for Standardization
NLGI : National Lubricating Grease Institute
ASTM : American Society of Testing and Material