

SPECIFICATIONS

1. MAJOR COMPONENT

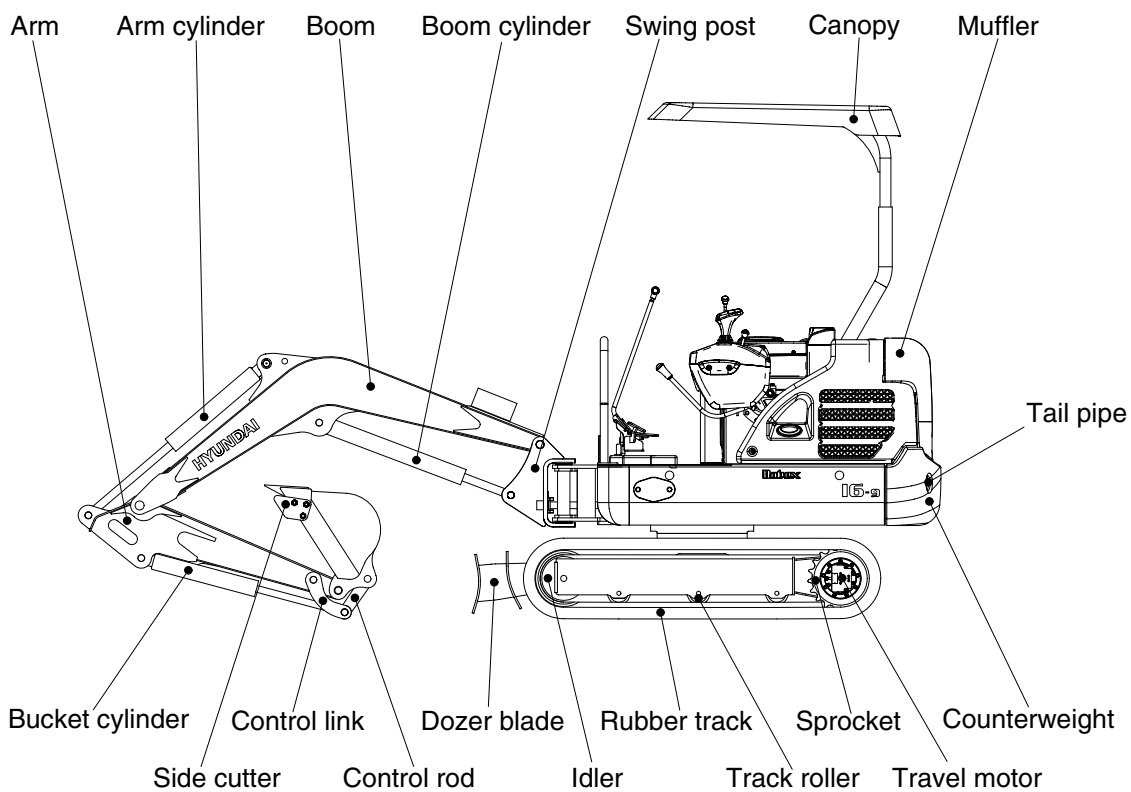
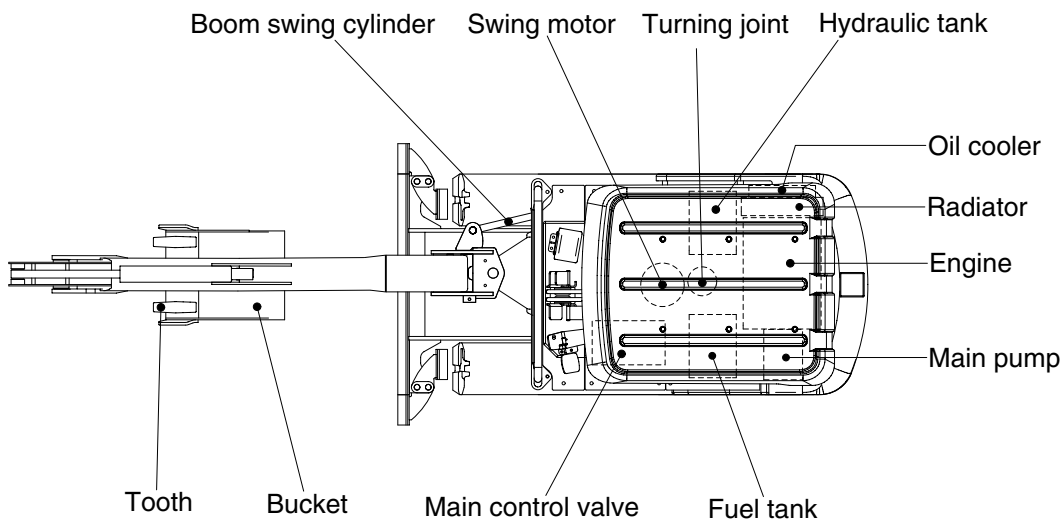

1692SP01