

# OPERATION MANUAL

*Relex* 15-7

SER. NO. HY1570001~

 **HYUNDAI**  
HEAVY INDUSTRIES CO.,LTD.



# INTRODUCTION

## **⚠ WARNING**

Read this manual carefully before operating the machine to ensure safe and optimum running conditions. If you do not understand any of the points in the manual, or the machine breaks down, contact your dealer. In particular, attention needs to be paid to the following points.

- Read this operation manual if you have any questions or doubts on any point to ensure proper and safety excavator operation.
- Keep this operation manual in the excavator at any time to ensure readily access to it in case a need for it arises.
- Be sure to hand over this operation manual to the new owner if the ownership of the excavator is to be transferred.
- Make every possible effort to ensure proper and safety operation of the excavator.

- Note that a portion of the contents of this instruction manual may differ from the excavator you have purchased, which is mainly due to the improvements adopted for it.
- Consult our marketing staff if you have any questions or comments on this operation manual.

# HOW TO USE THE OPERATION MANUAL

Read this manual carefully before operating the machine.  
This chapter describes the marks in the operation manual.

## Symbols:

### **DANGER**

This symbol shows an immediate hazard that will cause death or severe injury if the instruction is not observed.

### **WARNING**

This symbol shows a hazard that can cause death or severe injury if the instruction is not observed.

### **CAUTION**

This symbol shows a hazard that can cause injury of machine damage if the instruction is not observed.

### **IMPORTANT**

This symbol shows a hazard that can cause damages to the excavator or reduce its service life if the instruction is not observed.

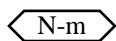

This symbol shows the tightening torque for a given bolt that needs to be strictly observed during the assembly.



This symbol shows related matters or the referring page.



This symbol shows the amount of grease or oil that needs to be filled.

- If you notice any ambiguous points in this manual, consult your dealer.
- The descriptions and figures in this operation manual may not coincide with the machine due to changes in the specifications.





# CONTENTS

## OPERATION

Safety Decals .....	1
Basic Precautions on Safety .....	3
Safety Precautionary Notes before Start .....	4
Safety Precautions during Operation .....	6
Safety Precautions during Inspection and Maintenance .....	15
Safety Post Operational Caution .....	18
Part Names .....	19
Explanation of Each Device .....	21
Operation .....	28
Operational Precautions .....	32
Transporting by Truck .....	38
Machine Traction .....	40
How to Hoist a Machine .....	41
Cold Weather or During-Winter Operations .....	43
Long-Period Storage .....	45

## INSPECTION AND MAINTENANCE

Ordering Parts and Servicing Guidelines .....	46
Inspections .....	47
Maintenance after the First 50 Service Hours (New Machine) .....	52
Maintenance after the First 100 Service Hours (New Machine) .....	53
Maintenance Every 50 Service Hours .....	54
Maintenance Every 100 Service Hours .....	56
Maintenance Every 250 Service Hours .....	57
Maintenance Every 500 Service Hours .....	58
Maintenance Every 1000 Service Hours .....	60
To Pressurize .....	61
Inspection and Maintenance Procedures for Engine Parts .....	63
Inspection and Maintenance Procedures .....	64
Periodical Inspections and Maintenance List .....	68
Lubricants .....	70

## OTHERS

Dimensions and Specifications .....	74
Hydraulic Circuit .....	76
Electric Circuit .....	77

# **OPERATION**

# SAFETY DECALS

## Explanations

### Caution:

Read the Operation Manual *before* operating the machine to avoid risk of injury.

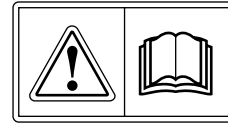

### Danger:

Make sure the engine is stopped before working of any part of the engine compartment to avoid risk of injury.

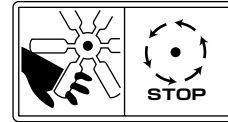

### Caution:Hot surfaces

Keep hands and arms away from hot surfaces.

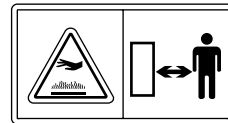

### Danger:Stay clear of the rear of the machine

Keep a safe distance from turning radius of the machine to avoid risk of injury.



### Danger:Stay clear of the working equipment

Keep a safe distance from turning radius of the boom, arm, bucket and any other lifting equipment to avoid risk of injury.



### Danger:Radiator

Attention to the danger of burning.



## TAKE CARE OF THE CONDITIONS OF THE SAFETY AND WARNING LABELS

- (1) Keep the safety and warning labels clean and legible.
- (2) Wash the labels with soap and water and dry with a soft cloth.
- (3) Replace damaged and lost labels with original stickers from your dealer.
- (4) Should a part with safety and warning labels be replaced with a new part, make sure that the new part has the same labels.
- (5) When replacing labels, make sure that underground is clean, dry and free from oil and grease.  
Press air bubbles toward the outside edges.

# LOCATION OF SAFETY DECALS

Part No. 11240-11650



Part No. 11240-11640

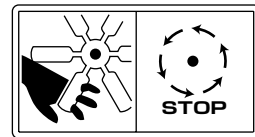
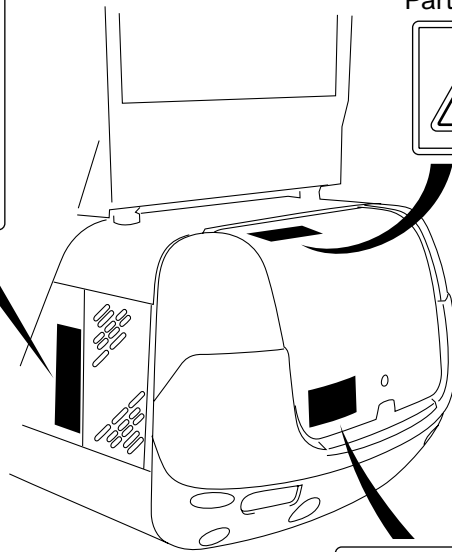
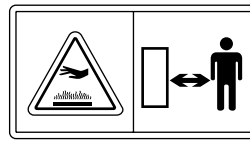

Part No. 11240-11630

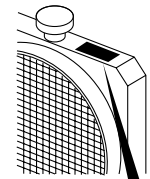

Part No. NTS6-10010

Part No. 11240-11660

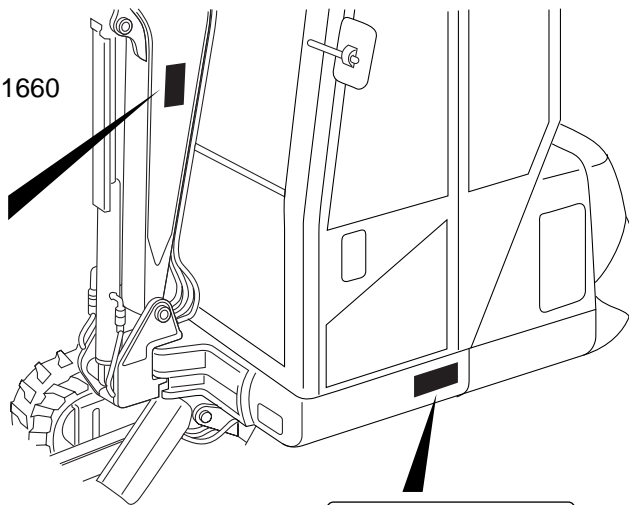
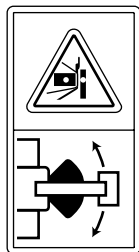

Part No. 11240-11620

# BASIC PRECAUTIONS ON SAFETY

## **⚠ WARNING**

### **Remodeling a machine is prohibited**

- The machine must not be remodeled without a permission of our company or our sales agent.  
Remodeling without the permission will lead to lower safety, inviting danger. Remodeling will not only deteriorate the functions of the machine but also shorten its life.
- We do not assume the responsibility for any accident or failure due to remodeling without our permission.
- For remodeling, make an inquiry about it at our office or our sales agent.

## **⚠ WARNING**

### **Precautions on options and attachments**

- Do not mount any part or attachment that has not been approved by us or our sales agent, on this machine.
- Using parts or attachments not approved by us will lower the safety, inviting danger.
- We do not assume the responsibility for any injury, accident, or machine failure due to using parts or attachments not approved by us.

# SAFETY PRECAUTIONARY NOTES BEFORE START

## ⚠ WARNING

### Secure safety in the work site.

- Before starting the work, investigate and record the topography and geological features of the work site completely to take proper measures for prevention against a machine turnover and earth/sand collapse.
- Do not start the work until the safety can be confirmed.

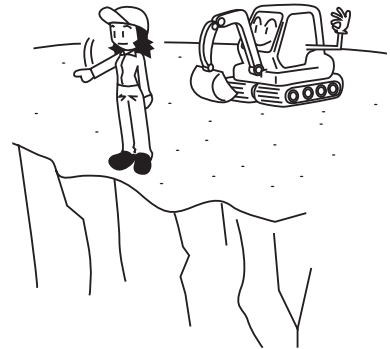

## ⚠ WARNING

### Always wear a hard hat and safety shoes.

Be sure to wear a hard hat and safety shoes when running the machine. Goggles and ear protectors may be necessary depending on the type of work. To prevent being caught in the machine, do not wear loose clothing.



## ⚠ DANGER

### Check the surroundings before start.

Look around you to check the safety of the surroundings before start. Before starting engine, fasten the seat belt surely. Do not carry out any maintenance work whilst the machine is suspended, using the dozer or arm.

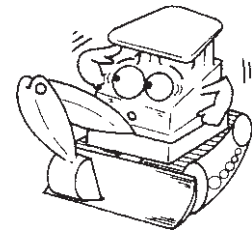

## ⚠ CAUTION

### Check the neutral position.

Before starting engine, always make sure that each operation lever and pedal are in neutral position. Do not place your foot on the pedal.

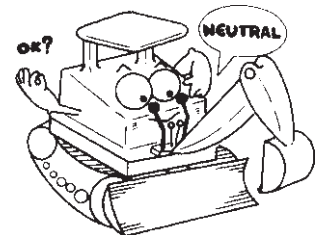

# SAFETY PRECAUTIONARY NOTES BEFORE START

## **⚠ DANGER**

### **Signal before start.**

Before starting the engine, travelling or swivelling, always signal to other workers, using the horn etc.

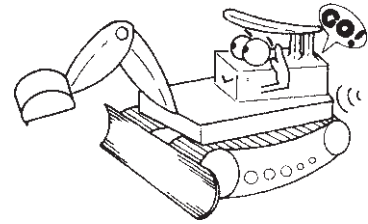

## **⚠ WARNING**

### **Pay attention to the ventilation.**

For indoor work or work in tunnel, ventilate sufficiently to prevent carbon monoxide poisoning from the exhaust.

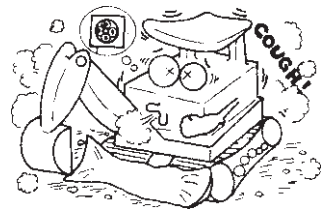

## **⚠ CAUTION**

### **Warm-up**

Before starting, always warm up the machine.

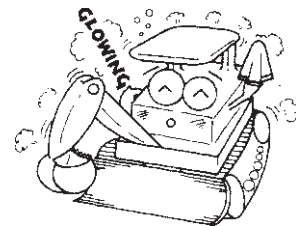

## **⚠ WARNING**

### **Prestart inspections**

Do prestart inspections. If you find any wrong point, you should repair the machine immediately. Using the machine having a trouble cause an accident.

☞ Refer to "Inspections" on page 47.

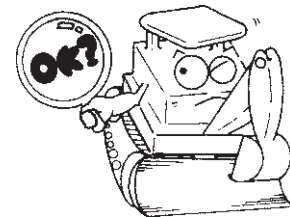

# SAFETY PRECAUTIONS DURING OPERATION

## **▲ DANGER**

### **Keep the area around the operator's seat clean.**

- Do not put anything at the foot of the operator's seat and around the pedals and do not hang anything on the control lever.

The control lever will be actuated by mistake, causing the machine to run away or the work equipment to be actuated. This is hazardous.

- Put unnecessary things for drive operations in good order in the specified place.

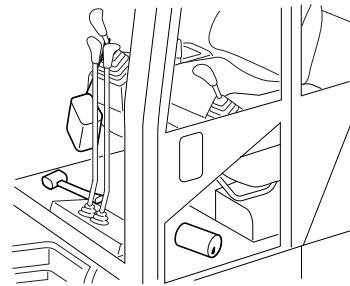

## **▲ WARNING**

### **Make the work visibility sure.**

- Wipe out floor surface, levers, handrails, windows, and lights to ensure the visibility.
- In the status where the window gets out of place or is broken, do not perform operations in any case.

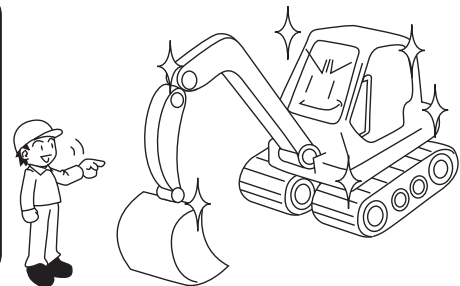

## **▲ WARNING**

### **Inspection of safety devices**

- Check all the safety devices including the lock lever and guard for correct installation, damage, and correct function. If any abnormality is found, repair it.
- Using any safety device incorrectly will lead to a serious accident resulting in injury or death. Be sure to use every safety device correctly.

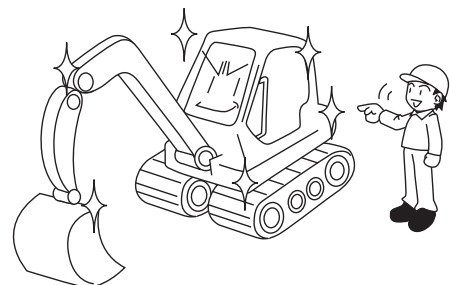

# SAFETY PRECAUTIONS DURING OPERATION

## ▲ WARNING

### Take care when getting on and off the operator's seat

- When getting on and off the operator's seat, be sure to hold on to the handrail facing the machine and put the foot on the track (caterpillar) to always hold the body at 3 or more points.
- Do not get on and off the operator's seat by holding the control lever of the work equipment.
- Do not jump on and off the machine.
- Do not get on and off the machine during travel in any case because it will invite danger.
- A turnover or crush under the track will be caused, leading to a serious accident resulting in injury or death.

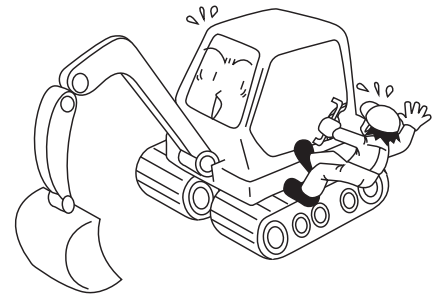
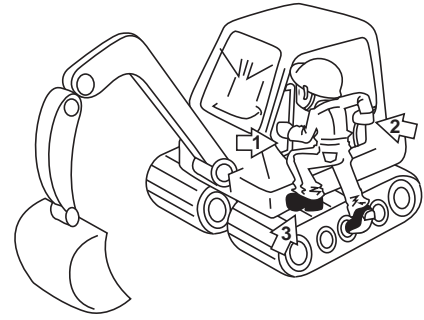

## ▲ WARNING

### Inspection and cleaning to avoid slippage

- Be sure to check the steps and handrails. If any damage, looseness, or any other abnormality is found, repair it.
- If any slippery substance such as oil and grease is attached to the steps, handrails, and caterpillar, remove it completely.

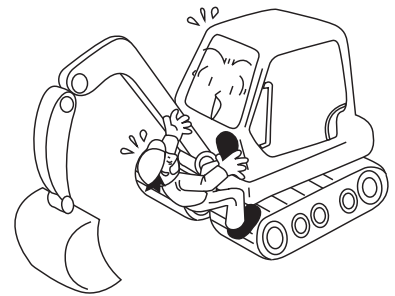

## ▲ WARNING

### Take care when opening or closing the front window.

- When opening or closing the front window, be sure to stop the engine beforehand. If the machine is actuated by touching the control lever by mistake, this may lead to a serious accident resulting in injury or death.
- After opening the front window, fix the window securely with the left and right lock pins. If the window slips down, this may lead to an accident resulting in injury or death.
- To avoid an accident resulting in injury or death, do not perform operations in the status where the window gets out of place or is broken.

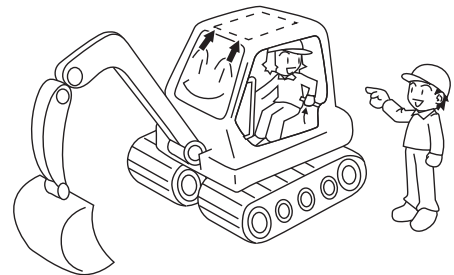

# SAFETY PRECAUTIONS DURING OPERATION

## ⚠ WARNING

### Start the engine and adjust the seat.

- To start the engine and perform drive operations, first take the operator's seat. Before starting the drive operations, adjust the control lever of the work equipment and the operator's seat position to a proper status.
- Make sure that there is no person around the machine, then start the engine.

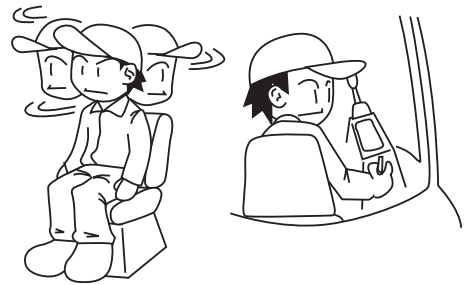

## ⚠ WARNING

### Starting by shorting is prohibited.

- Do not start the engine by shorting the starter terminal or battery in any case.
- The machine may be suddenly moved, inviting danger and the electric system may be damaged.



## ⚠ CAUTION

### Isn't any abnormal noise produced from a machine?

- During the work, take care about any abnormal noise from the engine, hydraulic device, travel component, work equipment, etc.

### The following items can be mentioned as abnormal noise.

- Isn't any creaky noise produced because of insufficient lubricating oil?
- Isn't abnormal frictional noise produced?
- Isn't any abnormal vibrating sound or rattling produced?
- Isn't irregular noise produced?
- Isn't any abnormal noise produced from the hydraulic device?
- Isn't any beating sound produced at a certain interval?
- Isn't any rumbling sound produced?

In case one of these items is detected, stop the operation at once and perform inspection.

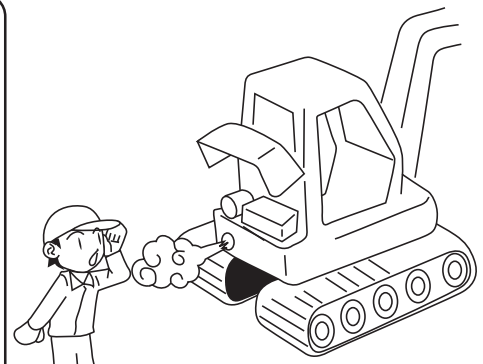

# SAFETY PRECAUTIONS DURING OPERATION

## IMPORTANT

### Is the temperature of the engine cooling water normal?

- Pay attention to the gauge position of the water temperature gauge. When the gauge indicates the white zone, this is normal.
- When the gauge indicates the red zone, reduce the engine rotational speed and suspend the work until the water temperature goes down. After the water temperature has gone down, stop the engine and check the cooling system.

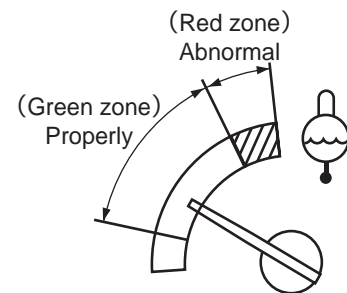

## IMPORTANT

### Isn't any water leak or oil leak found?

- Check the each portion of the machine to see if any water leak or oil leak occurs.
- If any water leak or oil leak is detected, stop the operation at once and make necessary repairs.

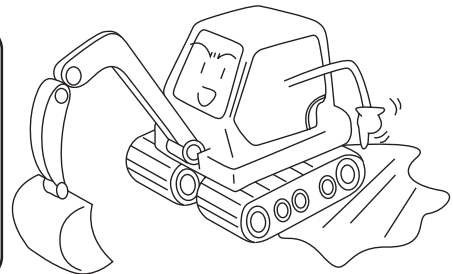

## ⚠ WARNING

### No admittance under the work equipment

- Man must not stay under the work equipment.
- When a machine is lifted by the work equipment or blade, do not stay under the machine in any case.
- Unexpected descend or natural descend of the machine will lead to a serious accident resulting in injury or death.

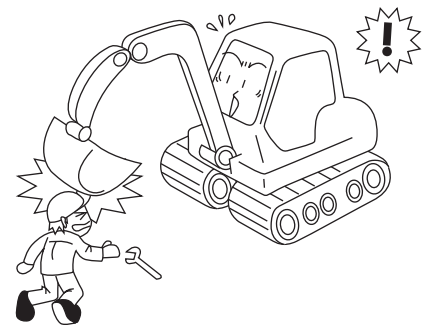

## ⚠ CAUTION

### Take care about an obstacle.

- When the work must be done close to any obstacle such as house and tree or when there is a limitation on height, take care about the obstacle.

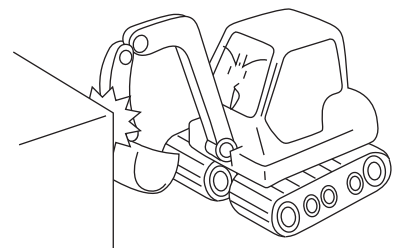

# SAFETY PRECAUTIONS DURING OPERATION

## ⚠ WARNING

### Do not carry any passengers.

Do not carry other persons on the machine during operations. It is unbalanced and dangerous.

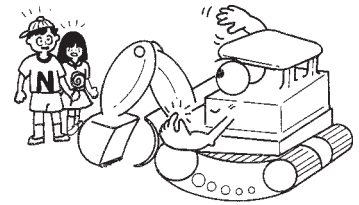

## ⚠ WARNING

### Do not remove cap of heated radiator.

Radiator cap must be removed after the water is cooled. The boiling water will injure you.



## ⚠ WARNING

### Do not touch the muffler.

Do not touch the muffler just after turning off engine. A hot muffler can cause personal injury.

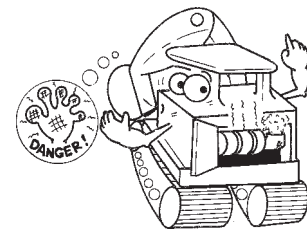

## ⚠ WARNING

### Take care about falling materials.

- When the excavating work on slope and the work in a tunnel, take care about falling materials such as falling rocks.
- Do not perform digging (excavation) under a precipice, which is especially dangerous. This will lead to precipice/ground looseness, degradation, and earth/sand fall.

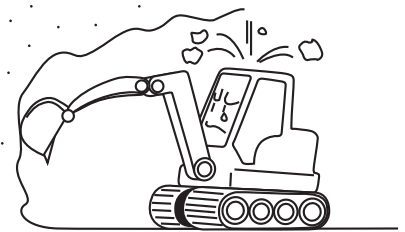

## ⚠ WARNING

### Prohibition of travel on a steep slope

- In any travel on a steep slope, do not travel over 25 degrees in the forward-reverse direction and 15 degrees in the lateral direction.
- In particular, crossing travel may cause a sideward slip or turnover. Avoid such travel in any way.

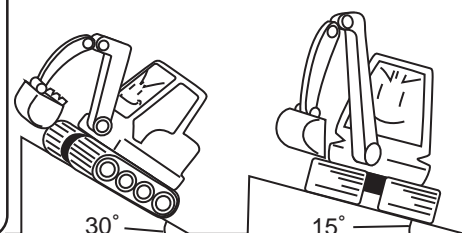

# SAFETY PRECAUTIONS DURING OPERATION

## ⚠ WARNING

### Precautions on route change on a steep slope

- A route change and crossing travel on a slope will lead to an overturn or a sideward slip. Avoid perform such operations.
- To change a route, move to a level ground or a gentle slope with solid ground.

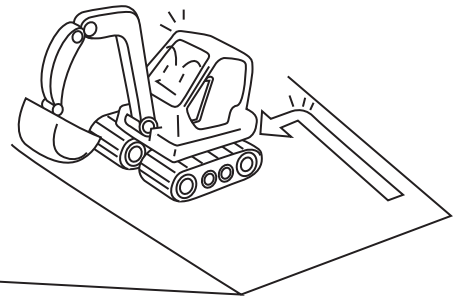

## ⚠ WARNING

### Take care about work on a slope.

- Regarding the work on a slope, take extreme care not to cause a turnover. On a slope, always put the caterpillar in the direction of slope while the work. When the work must be performed in a poor ground condition or with a crossing posture, perform leveling by piled soil to obtain a stable ground condition.

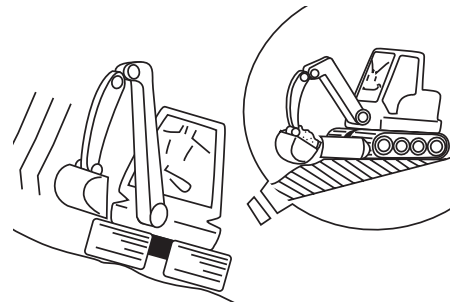

## ⚠ CAUTION

### Complete inspection and cleaning after the work

- Electrical components are very low resistant to water.
- Water invasion into various sensors, connectors, or electrical components of the electric system will result in trouble. Do not perform cleaning with steam and water.

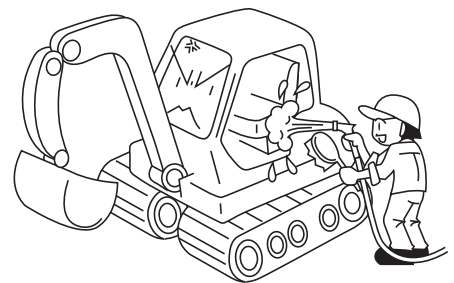

# SAFETY PRECAUTIONS DURING OPERATION

## **▲ DANGER**

### **Check for safety before going under the machine.**

Do not crawl under the excavator if the machine is only supported by the boom and arm or the dozer. The excavator can tip over or lower itself due to hydraulic pressure loss. Always use safety struts or other appropriate supports.

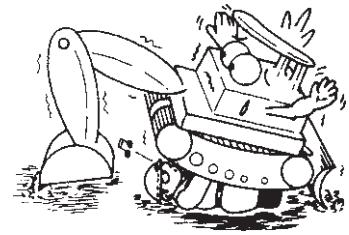

## **▲ WARNING**

### **Do not crane.**

Do not use this machine as object handling under any circumstances.

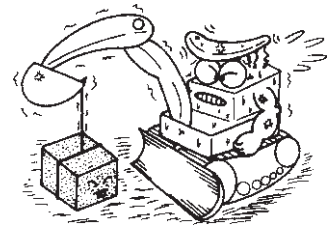

## **▲ WARNING**

### **Check the forward direction.**

Before operating the travelling lever, ensure the machine is facing in the right direction. I.e Dozer blade to front.

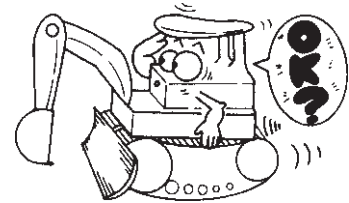

## **▲ WARNING**

### **Avoid turning on the slope.**

Avoid turning on a steep slope as the machine may slip.

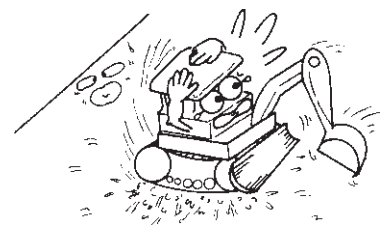

## **▲ WARNING**

### **Block the crawlers.**

If you park or stop the machine on a steep slope, drive the bucket teeth and the dozer into the ground and block the crawlers.

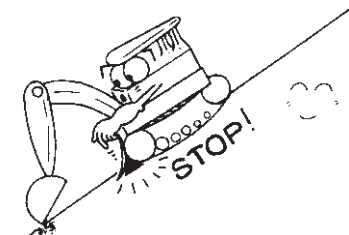

# SAFETY PRECAUTIONS DURING OPERATION

## ⚠ WARNING

### Precautions when a machine goes up and down on a slope

- When there is a possibility that the machine may slip in a slope, drive the machine slowly with the bucket kept at a height of 20 to 30 cm so that the work equipment may be folded and the bucket may be lowered. When causing the machine to go down, drive it especially slowly.

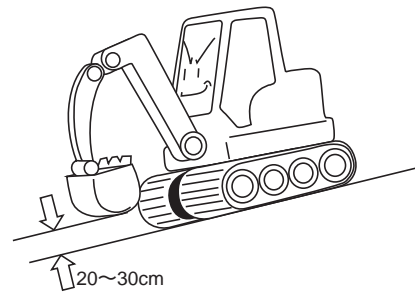

## ⚠ WARNING

### Precautions on work at a road edge

- A road edge or a precipice edge has soft ground and is hazardous. There is also a possibility of turnover and fall that may be caused by ground collapse due to machine weight and vibrations.
- Secure safe ground and start the work. When performing the work, set the track at a right angle to the road edge with the drive motor backward so as to facilitate a retreat.

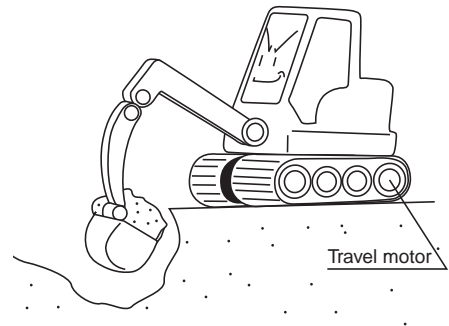

## ⚠ WARNING

### Precautions on work on piled soil

- When performing the work on piled soil or near a dug ditch, the piled soil tends to collapse so that the machine may suddenly tilt, causing a fall.
- After checking that the ground is safe, start the work. If the ground is deeply dug under the machine, the machine may fall down. Do not perform such an operation.

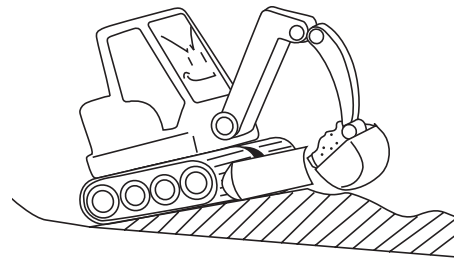

## ⚠ WARNING

### Precautions on travel on a frozen surface or snow surface

- For the work to be performed on ice or a frozen snow, avoid performing any sudden operation and reduce the speed. Sideward slip will easily occur and the operability will be more sensitive.
- When snow has lain much, road edges and installed materials are hard to see in the snow. Take extreme care in such a case.
- Frozen ground will often be softened as the temperature rises. Take care in such a case.

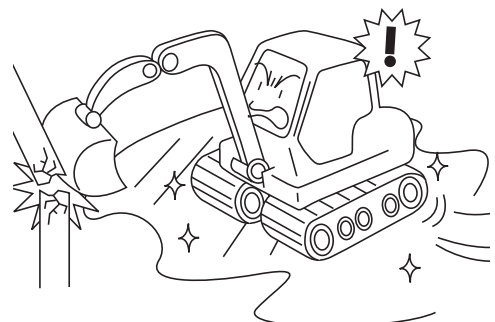

# SAFETY PRECAUTIONS DURING OPERATION

## ⚠ WARNING

### Put on protectors for inspection and maintenance.

- Put on safe protectors fit for the respective inspection or maintenance, for example, safety glasses or goggles, helmet, gloves, and safety shoes.

Working without protectors will invite danger such as burn and injury.

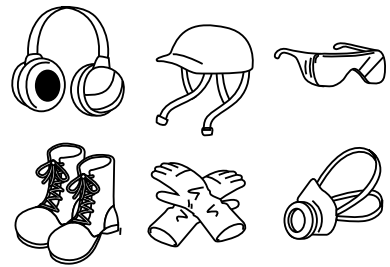

## ⚠ WARNING

### Stop the engine before starting the work.

- While the engine is running, the inspection or maintenance work is very hazardous. Be sure to stop the engine beforehand.

Start the work after the temperature of each device in the engine room goes down.

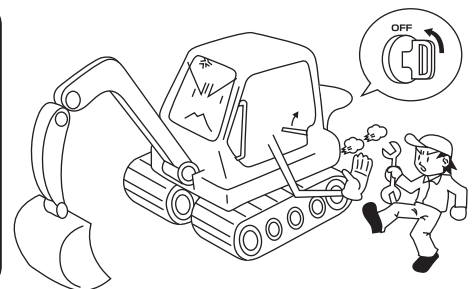

## ⚠ CAUTION

### Inspection and maintenance while the engine is rotating

- In case maintenance cannot be performed unless the engine is run, set the lock lever to the "Lock position" and be sure to perform the work with two or more workers including one assistant worker.
- The assistant worker should sit on the operator's seat so that he can immediately turn off the engine in an emergency. In this case, do not touch any lever except the necessary one.



## ⚠ WARNING

### Attention to noise

- If the worker is exposed to noise for a long time during engine inspection or maintenance work, auditory sense trouble may be caused.
- In such a case, put on ear-plugs or ear-covers.

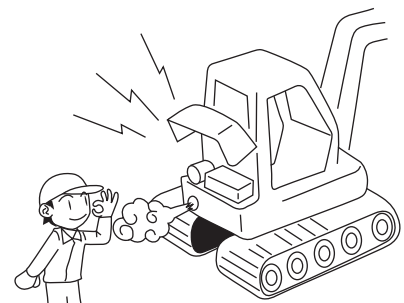

# SAFETY PRECAUTIONS DURING INSPECTION AND MAINTENANCE

## ⚠ WARNING

### Rotating parts are hazardous.

- Do not touch any rotating part in any case. If the human body or tool touches a rotating fan, pulley or belt, it will be caught, thereby causing in an accident resulting in injury or death.
- For inspection and maintenance, be sure to stop the engine.



## ⚠ WARNING

### Taking care about scattering materials during hammering work

- When solid metals must be struck, for example, at pin installing or removing work, broken pieces of earth, sand, and rock may scatter, thereby inviting danger.
- When starting installing or removing pins, check if there is no person around the work place.
- For performing hammering work or grinding work, put on safety glasses or goggles.

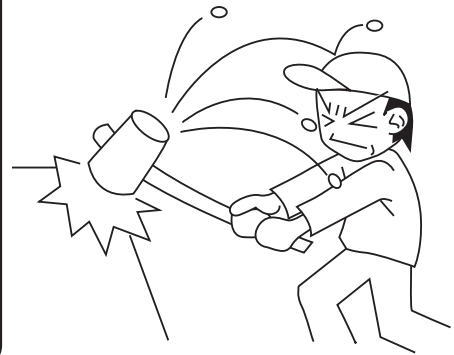

## ⚠ WARNING

### Take care in removing hydraulic parts.

- When the engine oil or hydraulic oil may be of high temperature or high pressure, this involves a hazard. If a hose or cap is removed carelessly, high-temperature or high-pressure oil may blow off, giving a serious injury to the eyes and skin.
- Stop the engine and wait until the oil temperature goes down. Relieve the pressure of the hydraulic system. After that, start the removing work.
- If the hydraulic oil invades the human body, consult a doctor to receive proper medical treatment.



# SAFETY PRECAUTIONS DURING INSPECTION AND MAINTENANCE

## **⚠ WARNING**

### **Take care about high-pressure grease**

- The grease cylinder adjusting the track tension is prepacked with grease with the result that the grease may be of high pressure. In this status, if the plug is loosened carelessly, the plug and grease may spring out, inviting danger.
- When reducing the pressure by turning the cartridge valve (lubrication valve), do not turn the valve more than one turn. Do not face the worker's body to the front side of the cartridge valve or bring the face close to it.
- Do not disassemble the recoil spring, otherwise it may lead to a serious accident resulting in injury or death.

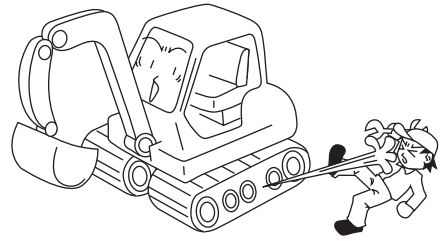

## **⚠ WARNING**

### **Prevention against the danger of fire or explosion**

- Take care when handling combustible materials such as fuel, oil, and antifreeze etc. If fuel leaks onto electric system parts, this may result in ignition.
- Perform fuel supply and oil supply outdoors and keep fire and a light away.- If fuel, oil, or any other combustible solution spills out onto a machine, remove it at once.
- Do not heat a fuel tank and a hydraulic device or bring fire near them, otherwise ignition may be caused.
- Put each of fuel and oil in a proper container and store it in a safe place that does not allow any person other than persons concerned to touch it.

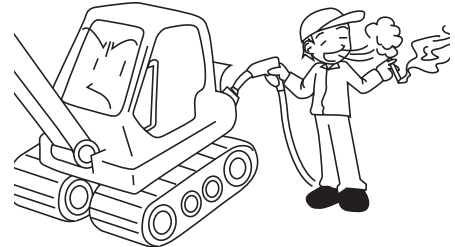

# SAFETY PRECAUTIONS DURING INSPECTION AND MAINTENANCE

## **⚠ WARNING**

### **Precautions on welding repair**

- Take a fire preventive means at welding work.
- Only qualified persons are allowed to perform welding.
- Perform welding in a place well equipped with an air ventilation system.
- Peel off the paint provided on the weld portion before starting welding.
- Do not weld or gas-cutoff a pipe or tube containing a combustible solution, otherwise this may lead to a fire or explosion.
- Start welding or gas-cutoff after cleaning with an incombustible solution.
- When welding repair work is done, the paint will be burnt by weld heat or hazardous gas may be produced.

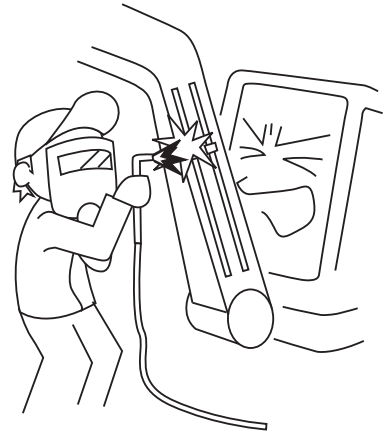

## **⚠ WARNING**

### **Take care in handling waste liquid.**

- For environmental protection, take extreme care about the disposal of waste including waste liquid and battery.
- Be sure to receive waste liquid with a container such as oil-can.  
Do not discharge untreated liquid into a river, swamp, and ground in any case.
- When discharging the following toxic substances, observe the specified rules.
  - Oil and grease, filter, battery
  - Refrigerant and coolant
  - Other toxic substances

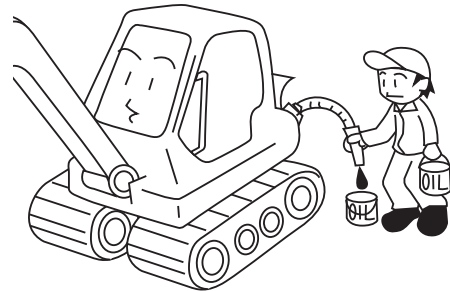

# SAFETY

## POST OPERATIONAL CAUTIONS

### **⚠ WARNING**

#### **Be sure to remove the key.**

Before leaving the machine, lower the bucket and the dozer on the ground. Stop the engine and remove the key. Cover the swing and PTO pedals.

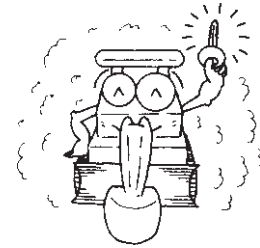

### **⚠ WARNING**

#### **Park the machine on a level surface.**

Select a safe and level surface when parking the machine. If it is necessary to park on a slope, block the crawlers with chocks at right angles to the slope. Drive the bucket teeth and the dozer into the ground.

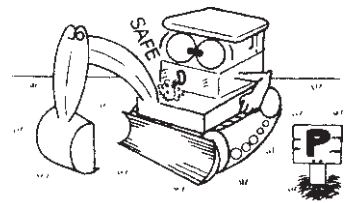

### **⚠ CAUTION**

#### **Post operational inspections.**

After operation, inspect the entire machine and lubricate.

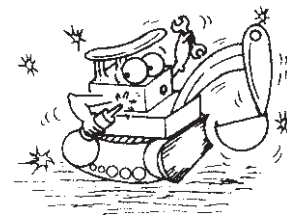

# PART NAMES

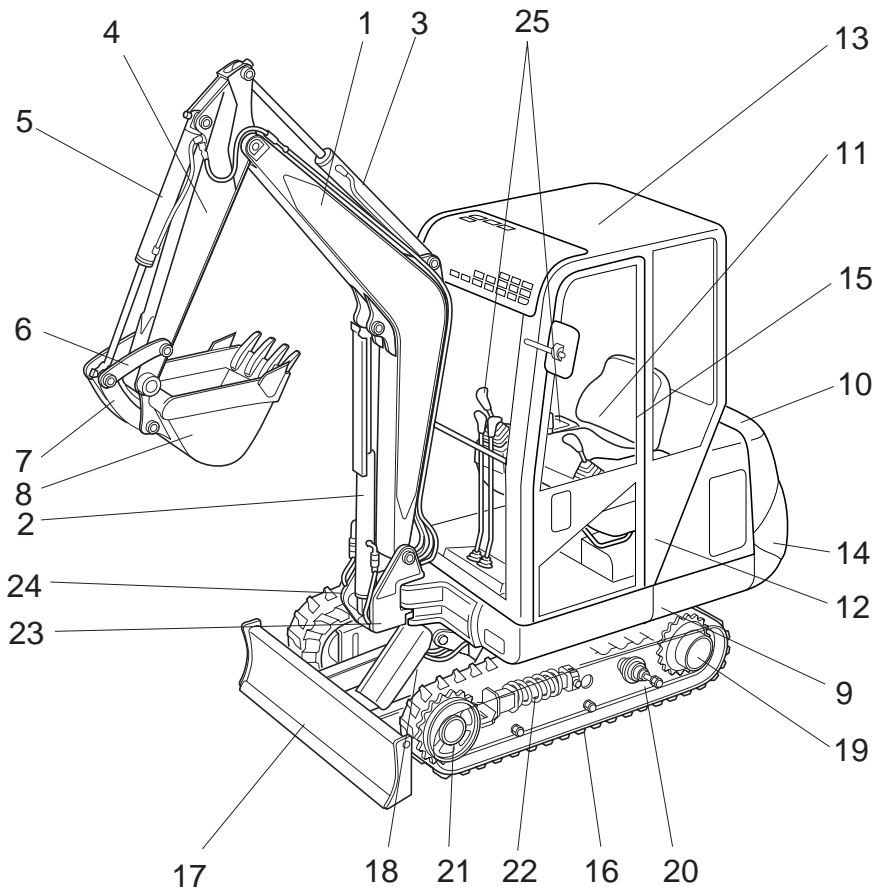

- |                       |                     |
|-----------------------|---------------------|
| 1. Boom               | 2. Boom cylinder    |
| 3. Arm cylinder       | 4. Arm              |
| 5. Bucket cylinder    | 6. Bucket links     |
| 7. Dump link          | 8. Bucket           |
| 9. Swing frame        | 10. Engine cover    |
| 11. Fuel tank         | 12. Hydraulic tank  |
| 13. Cabin             | 14. Counter weight  |
| 15. Operator's seat   | 16. Crawler         |
| 17. Dozer blade       | 18. Dozer cylinder  |
| 19. Drive/Track motor | 20. Track roller    |
| 21. Front idler       | 22. Grease cylinder |
| 23. Swing post        | 24. Swing cylinder  |
| 25. Operation levers  |                     |

# PART NAMES

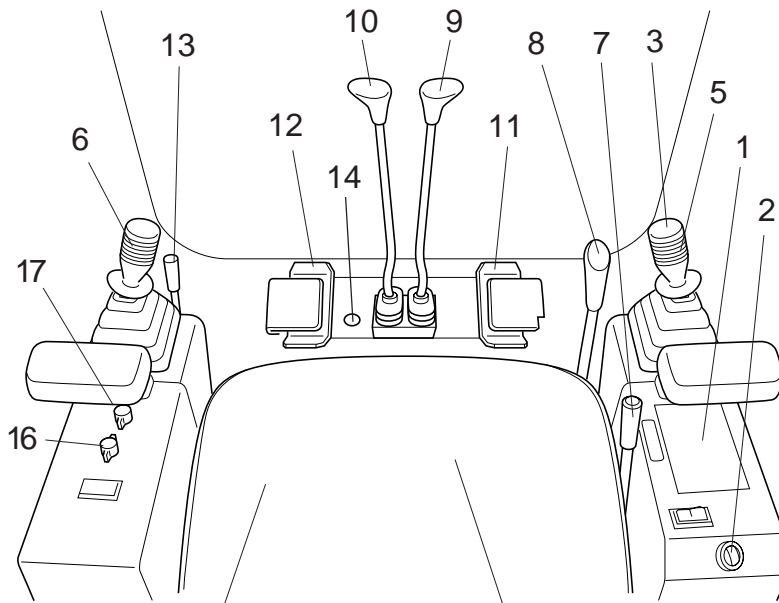

1. Meter unit
2. Starter switch
3. Horn switch
4. Fuse box
5. Right operation lever
6. Left operation lever
7. Accelerator lever
8. Dozer lever
9. Right travelling lever
10. Left travelling lever
11. Swing pedal
12. P.T.O. pedal
13. Safety lock lever
14. Swing lock pin
15. P.T.O. select lever
16. Heater switch
17. Wiper switch
18. Manual boom lowering lever

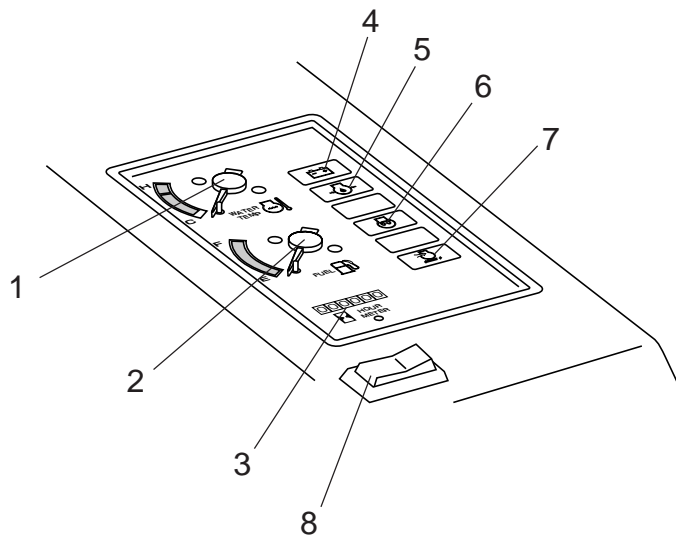
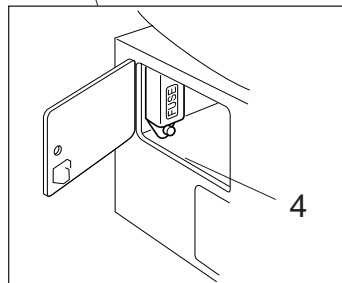
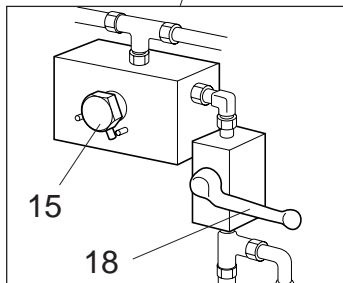

1. Water temperature meter
2. Fuel gauge
3. Hour meter
4. Charge lamp
5. Engine oil pressure lamp
6. Glow lamp
7. Air filter lamp
8. Head light switch

# EXPLANATION OF EACH DEVICE

## ⚠ WARNING

Carefully read the instructions shown in this section to have a thorough knowledge on the operation method of the respective controls, meanings of the indicator LEDs, and precautions for the work to ensure safe and unhindered work.

## ⚠ WARNING

If the indicators of monitor panel tell you problems, you must stop the engine and check the machine. If necessary, you must repair.

## ⚠ CAUTION

Clean up the monitor panel surface with wet clothes. With dry clothes using, scratches prevent your observation.

### 1. Water temperature meter

Indicates the temperature of engine coolant. It's normal if the meter indicates the green area after started engine and warmed up. If the meter indicates the red area, open the engine hood to cool the engine. When the pointer goes down, stop engine and check the level of radiator tank, leakage, the dirt of radiator core and looseness of the fan belt after the engine cooled.

### 2. Fuel gauge

Indicate the level of fuel in the tank. Refill tank when the pointer is close to "E".

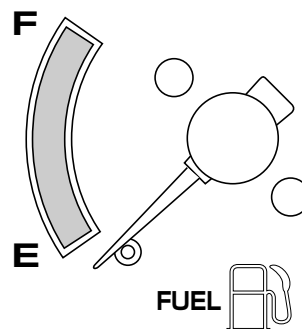
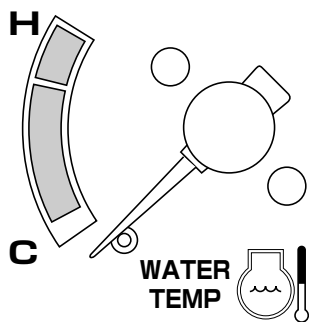

## IMPORTANT

- Each indicator would not show until turning starter switch to ON position.
- Confirm the level of fuel before starting the work.

# EXPLANATION OF EACH DEVICE

## 3. Hour Meter

Indicates the accumulated operating time in 0.1 hours (six minutes), which is the reference for the inspection.

### IMPORTANT

This meter keeps running while working the engine.

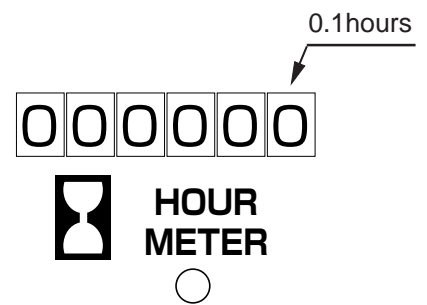

## Warning lights

### 4. Charge lamp

Light when trouble occurs on the battery charging system. If the lamp is lit, check the charging system and fan belt tension.

☞ Refer to "Inspection" on page 50.

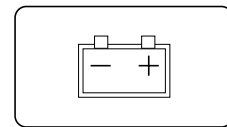

### 5. Engine oil pressure lamp

Light when the engine oil pressure drops abnormally and also when the engine stops. After the engine stopped check the lubricating system.

☞ Refer to "Inspection" on page 47.

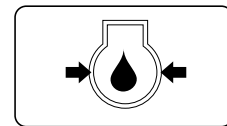

### 6. Glow lamp

Turning the key switch ON lights for six seconds. If the engine is warmed up, it does not light.

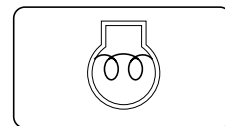

### 7. Air filter lamp

Light when air cleaner element clogged.

☞ For details refer to page 64.

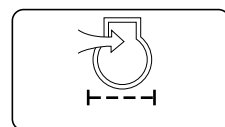

### IMPORTANT

Jammed air cleaner let the engine performance down.

### 8. Head light switch

Press the switch to light the lamp mounted on the cabin and also light the panel illumination lamp.

# EXPLANATION OF EACH DEVICE

## Starter switch

Use the main switch as a starter switch to start the engine.

☞ For details refer to page 29.

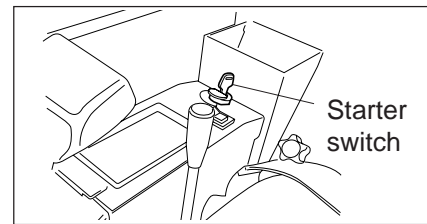

## Horn switch

Press the switch on the right operation lever to blow the horn.

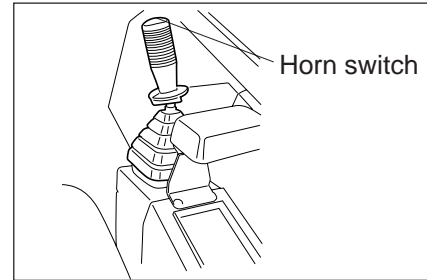

## Fuse box

Turn the knob to remove the cover. Four fuses for 10A each are fixed on the circuit for safety.

### ⚠ CAUTION

After turning the starter switch OFF, replace the fuse. Don't substitute the steel wire, or electric system will be damaged. If fuses are frequently damaged, electric system may have a something trouble.

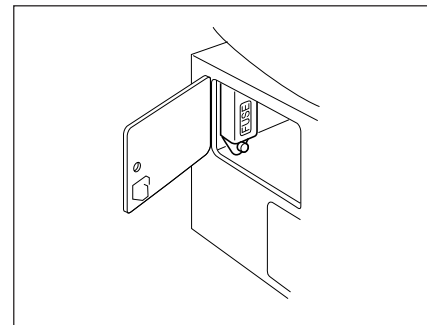

## Heater switch

This switch can be set to either LOW or HIGH in terms of air flow.

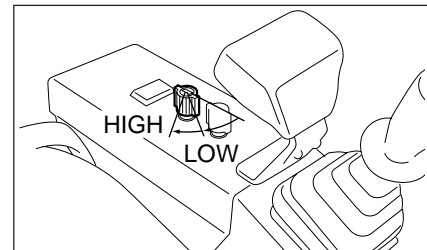

## Wiper switch(for Cabin)

This switch also functions as a washer switch.

- 1:Activates the wiper.
- 2:Activates the washer system.
- 3:Activates the wiper and the washer system.

### ⚠ CAUTION

Using washer fluid continuously for more than 20 seconds or activating the washer tank when it is empty may damage the motor in the tank.

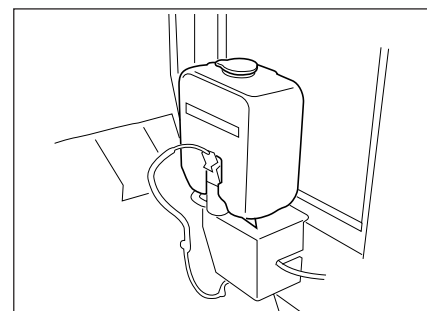
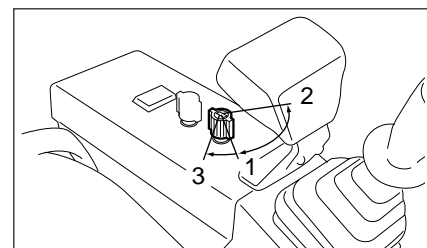

# EXPLANATION OF EACH DEVICE

## Operation lever

With the left hand joystick in the forward position, only the operator can control the working equipment.

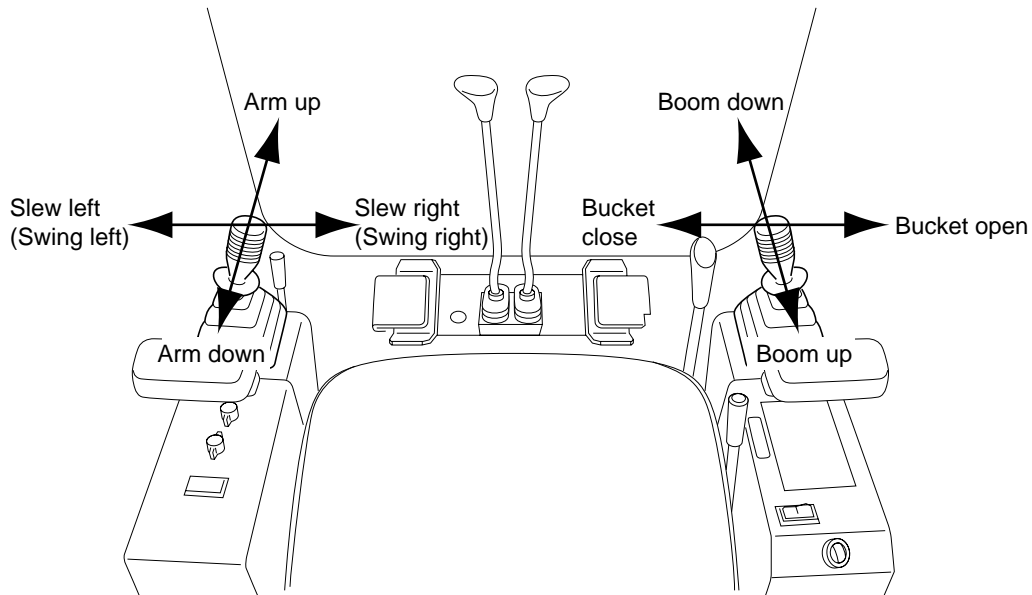

### ⚠ WARNING

To avoid bodily injury, operate controls from the operator's seat only.

### ⚠ DANGER

Confirm the safety within the working area and blow the horn before slewing. Keep unauthorized person away from the working area.

### ⚠ CAUTION

- Take dangerous things and obstacles away in advance before the work.
- Don't move the boom rapidly particularly downward, or the track frame is damaged.

# EXPLANATION OF EACH DEVICE

## Travelling lever

Push this lever forward or rearward to start the travelling. Confirm which way you are facing to operate the lever.

### ⚠ CAUTION

Confirm which way you are facing to operate the lever.

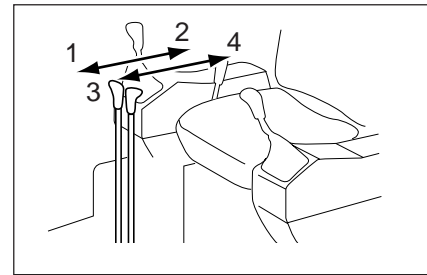

## Right travelling (dozer at the front)

1. Right crawler travelling forward
2. Right crawler travelling backward

## Left travelling (dozer at the front)

3. Left crawler travelling forward
4. Left crawler travelling backward

### IMPORTANT

The machine doesn't have a trouble in case it becomes rapidly slow when other operation (swing, boom, etc.) is done with travelling.

## Dozer operation lever

1. Dozer raising
2. Dozer lowering

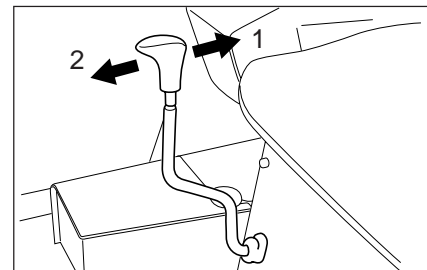

## Acceleration lever

Vary the revolution of engine. Push forward the lever to reduce the revolutions and pull backward to increase the revolutions.

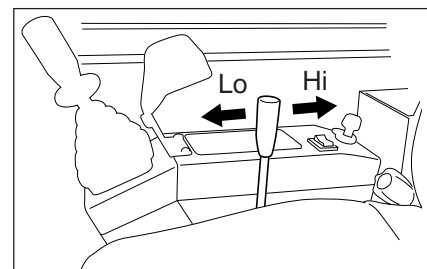

# EXPLANATION OF EACH DEVICE

## Swing pedal

1. Right swing
2. Left swing

### **▲ WARNING**

Make a stopper to swing pedal certainly while travelling or when swing pedal is unnecessary.

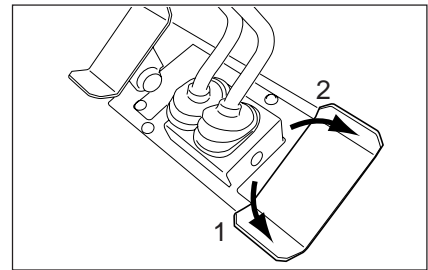

## Overdrive pedal

To accelerate this machine, depress this pedal. Depressing it accelerates the machine, while letting go of it decelerates the machine.

### **IMPORTANT**

For spinning or pivoting, make sure that the machine is travelling at a low speed.

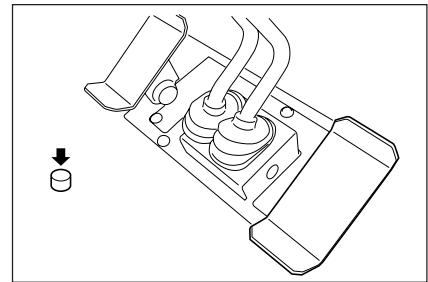

## P.T.O. pedal

P.T.O. operational when pedal is depressed.

P.T.O. is off when pedal is released.

If single piping is fitted then only one side of pedal is operative.

### **▲ WARNING**

Make a stopper to P.T.O. pedal certainly while travelling or when P.T.O. pedal is unnecessary.

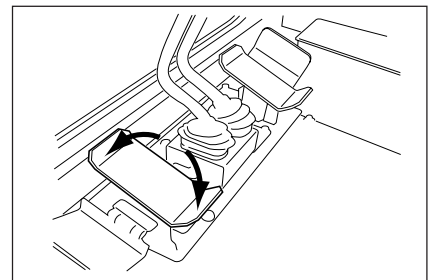

## Safety lock lever

Pull up the lever when you get on or off the machine, lever stand raises. To turn, lock the lever firmly and check.

When lever stand raises, the machine doesn't work even you operate the right and left operation levers.

### **IMPORTANT**

Pulling up the safety lock lever makes the engine stop.

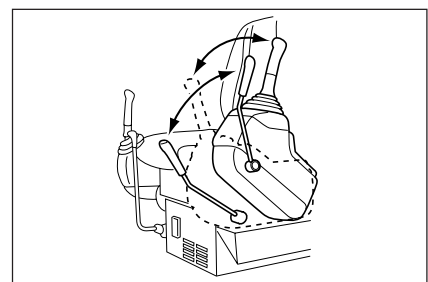

# EXPLANATION OF EACH DEVICE

## Slew lock pin

Slew lock pin can be effective whether the upper structure faces forward or backward.

### IMPORTANT

Lock the slew when travelling or transporting the machine.

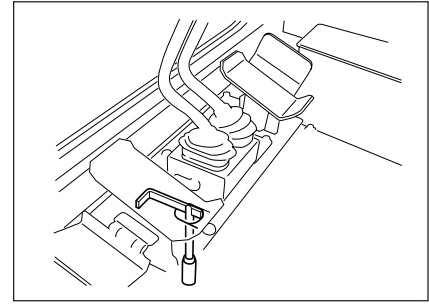

## P.T.O. select lever

Select the lever for the purpose of using P.T.O..

1. Breaker (to Tank)
2. Swing bucket, etc. (to Valve)

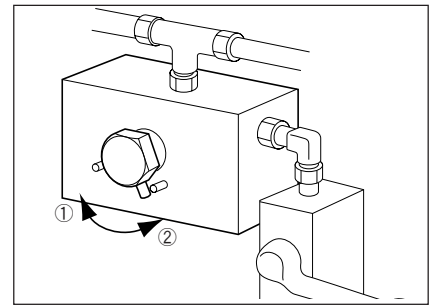

## Manual boom lowering lever

Incorporated in the boom circuit is a manual lowering valve, this valve allows the boom to be lowered should the engine or hydraulics fail.

1. Lower the boom
2. Normal position.

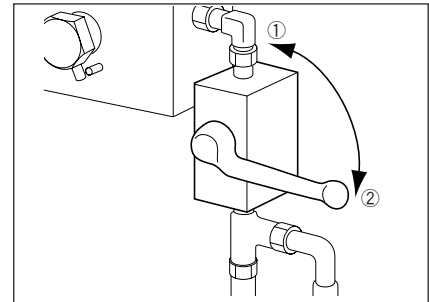

# OPERATION

## MACHINE RUNNING-IN

### 1. Precautions to running in the new machine

The new machine was inspected and adjusted completely on delivery from the factory. However, be sure to inspect it as follows before use. For the first 50 service hours, warm up at 60 to 70% of full load.

Do not operate at an unreasonable load. Trouble may occur, thereby reducing the service life.

- Body  
Check if there are any damaged or loose parts caused during transit.
- Control system  
Check if there is an abnormality in the operation of the control lever and control unit.
- Cooling system  
Check if the radiator coolant is filled to the specified level and water leakage occurs or not. Check also expansion tank level
- Engine system  
Check that engine is filled with the proper amount of oil.  
Check for oil and fuel leakages.
- Electric system  
Check for loose wiring, battery fluid level and loose terminal connections.
- Greasing and lubricating  
Check if the parts are greased and lubricated sufficiently.  
Check the crawler tension.

### 2. Replacing engine oil and elements of the new machine

- Replace engine oil and elements of the new machine after 50 service hours.
- Replace the line filter of the new machine after 100 service hours.
- Clean the suction filter of the new machine after 100 service hours.
- Replace the gear oil for the travelling and reduction gears of the new machine after 500 service hours.

☞ **Refer to "Lubricants" on page 78.**

# OPERATION

## BEFORE STARTING ENGINE

- 1) Execute the inspection before starting operation.  
☞ **Refer to "Inspection" on page 47.**
- 2) Make sure of the travelling lever at neutral.
- 3) Push back the acceleration lever to revolve the engine at medium speed or more.
- 4) It is normal that the lamps light up at "ON" and should go out as the engine starts running.

### ⚠ CAUTION

- Starting up with the accelerator lever at full stroke is very dangerous.
- Look around the machine to confirm that no unauthorized person is within the working area and blow the horn before starting the engine.

## STARTING PROCEDURE

1. Turn the key from OFF to GLOW, and the charger and lamp circuits are electrified.  
Leave it for 5 seconds to pre-heat the starter before turning the key to START.
2. Turn the key from ON to START. Engine starts running.
3. Immediately take your hand off the key when the engine starts.

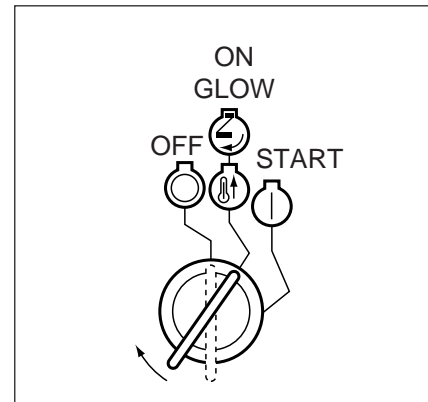

### ⚠ CAUTION

Do not continue to operate the starter for more than 15 seconds. To do so will damage the starter. If engine does not start, return the key to the OFF position and try again after 30 seconds.

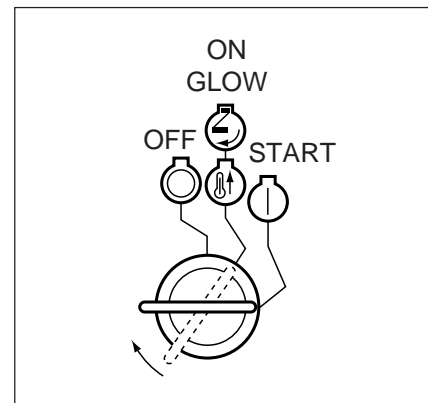

4. Return the accelerator lever to the idling position to warm up the machine.

### ⚠ CAUTION

Never turn the key to START while the engine is running.

### IMPORTANT

If engine does not start after several attempts, check the fuel level and battery.

# OPERATION

## PRECAUTION AFTER STARTING ENGINE

1. Idle engine until the warning lights go out.
2. Do not accelerate rapidly until the machine is warmed up.

### IMPORTANT

Sufficiently warm up the engine before starting the work if the machine is to be operated in the wintertime or frigid region.

## STOPPING ENGINE

1. Slowly work left and right operation levers to lower the bucket on the ground.
2. Before stopping engine, idle it for about 5 minutes to cool it down.
3. Return the accelerator lever to engine stop position.
4. Return the starter switch to OFF and remove the key.

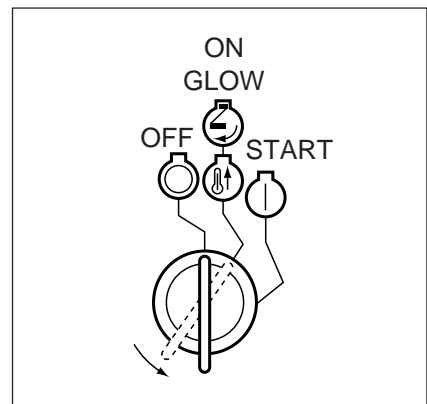

### IMPORTANT

Leaving the starter switch ON after stopping engine will drain the battery. Always turn off the starter switch after stopping engine.

# OPERATION

## TRAVELLING

1. Fold the boom and arm. Raise them to 40 to 50 cm above the ground.
2. Raise the dozer blade at minimum stroke.
3. Check the direction you want to go. Move the left and right crawler operation levers forward for forward travelling or backward for reverse travelling.

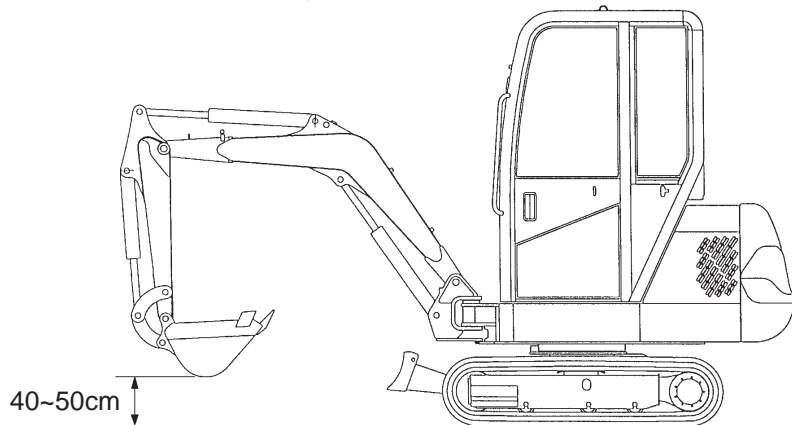

### Turning the Stationary Machine

Push the left travelling lever forward to turn the machine to the right. Pull the left travelling lever backward to turn the rear of the machine to the right.

### Turning the Machine while Travelling

#### 1. Left pivot-turn

Return the left crawler lever to neutral position with the right crawler lever pushed forward.

#### 2. Right pivot-turn

Return the right crawler lever to the neutral position with the left crawler lever pushed forward.

#### 3. Spin turning

Turning the left crawler lever forward and right crawler lever backward and the machine spins rightward. For the spin leftward, operate in the opposite way.

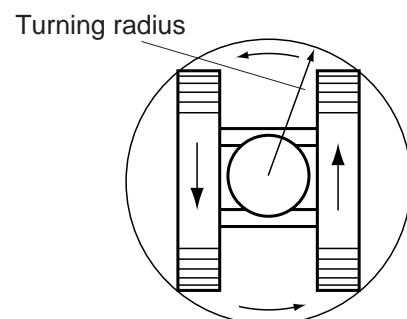
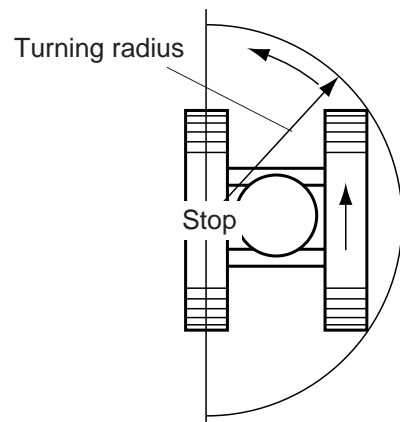

### **CAUTION**

You cannot make a spin turn or a pivot turn at high speed.  
A spin turn on the concrete surface damaged rubber shoes.

# OPERATIONAL PRECAUTIONS

## ⚠ CAUTION

Do not try to crush concrete or boulders using side swing with the bucket.

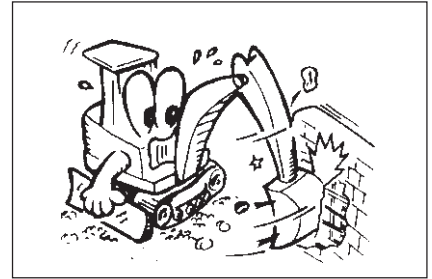

## ⚠ CAUTION

Do not let the bucket free-fall when digging.

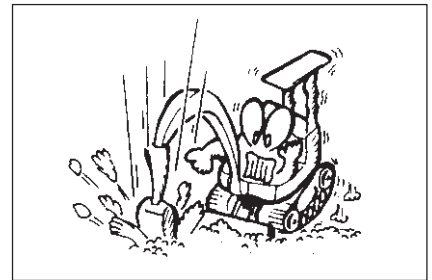

## ⚠ CAUTION

Do not fully extend the cylinders. Always leave a margin for safety.

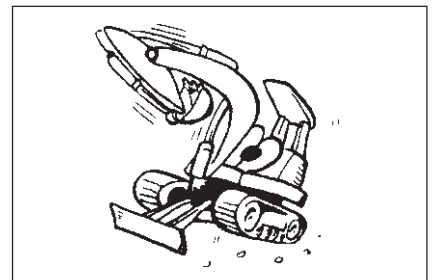

## ⚠ CAUTION

When travelling down a steep slope, reduce the speed to a safety range with the travelling lever.

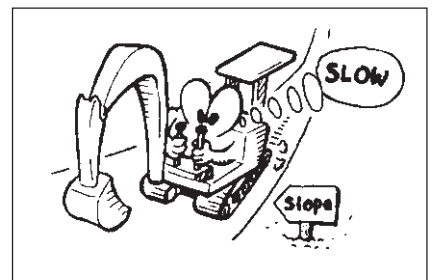

## ⚠ CAUTION

Do not dig or use the bucket by an impact to hammer a pile into the ground.

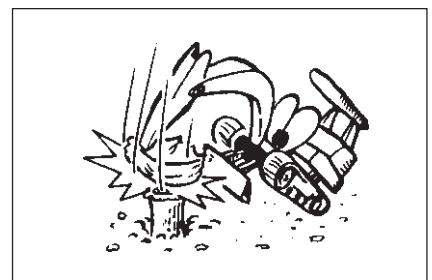

# OPERATIONAL PRECAUTIONS

## ⚠ CAUTION

Do not travel or dig with the bucket forked in the ground.

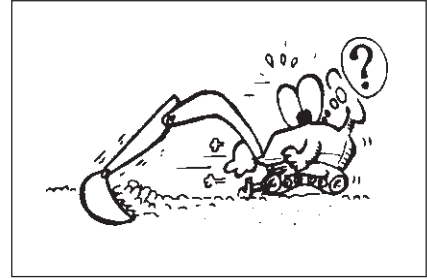

## ⚠ CAUTION

For scooping the earth, do not deeply fork the bucket. Instead, dig with the bucket at shallow levels at a long distance from the body. This gives less load on the bucket.

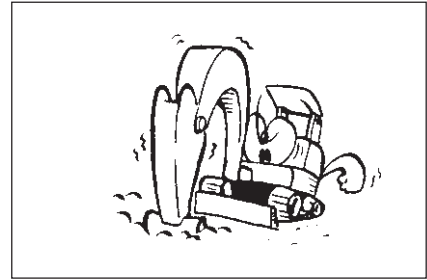

## ⚠ CAUTION

This machine can be used in the water if the slew bearing is above the water level.

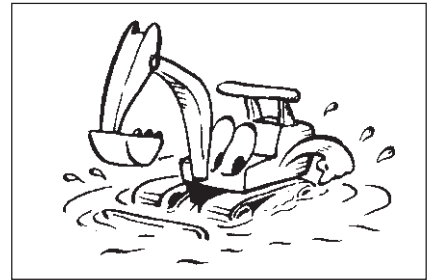

## ⚠ DANGER

When operating near overhead power lines, enclose the power lines or apply insulating protectors around power lines. In case of the high-voltage line, it is dangerous. Even when the machine directly contact it, you may be struck by electricity.

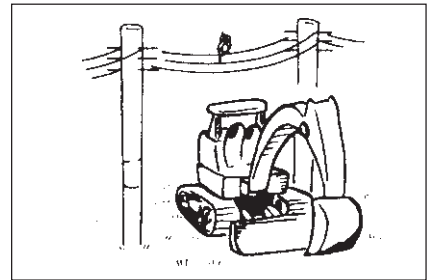

## ⚠ CAUTION

When travelling or transporting the machine with its boom folded, do not let the bucket come in contact with the dozer.



# OPERATIONAL PRECAUTIONS

## ▲ CAUTION

After the operation in the water or muddy water or seawater, always clean up and inspect the machine and grease the pins on the bucket, slew bearing, and other immersed parts until the old grease comes out.

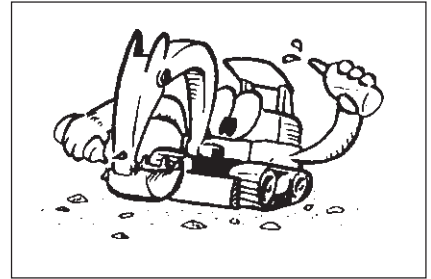

## ▲ CAUTION

Digging while facing backwards, prevent the boom cylinder from coming into contact with the dozer.

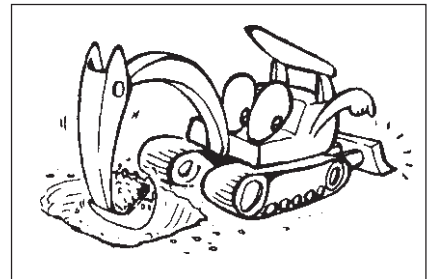

## ▲ WARNING

Do not use this machine as object handling under any circumstances.

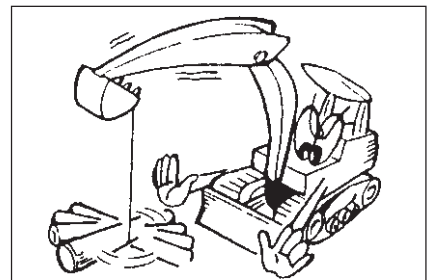

## ▲ CAUTION

Do not move the boom rapidly particularly downward, or the track frame is damaged.



## ▲ CAUTION

Do not lifting up the machine while it is swinging, or the machine may fall.

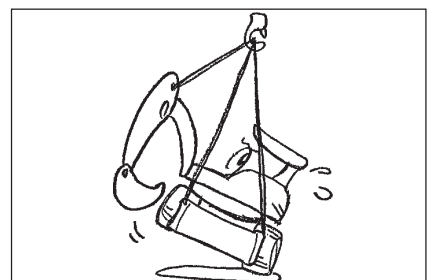

# OPERATIONAL PRECAUTIONS

## ⚠ CAUTION

Do not operate the machine heavily under the swing condition, or the boom may be damaged.

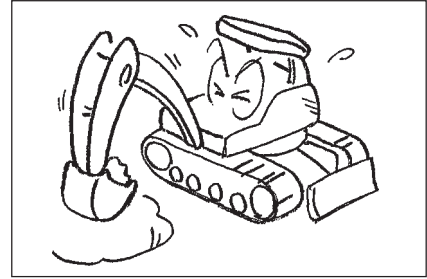

## ⚠ CAUTION

In case of working in unbalanced place, make a balancing before working.

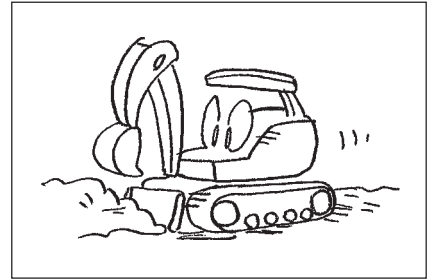

## ⚠ CAUTION

Take care of the tail of the machine not to hit anything while turning.

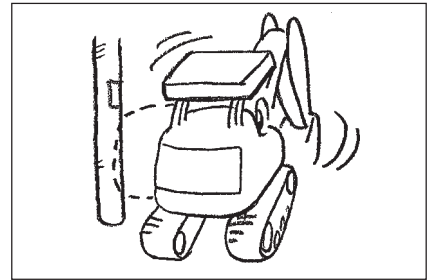

## ⚠ CAUTION

Never fail to make sure that a new attachment don't hit the boom or the arm before starting the work.

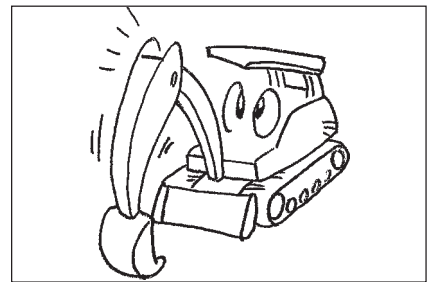

## ⚠ CAUTION

When digging deeply, take care to prevent the boom cylinder or the arm from hitting the ground accidentally.

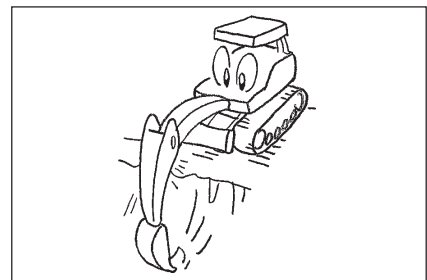

# OPERATIONAL PRECAUTIONS

## ▲ CAUTION

Do not attempt to move rocks with the blade, this will damage the blade and the blade cylinder.

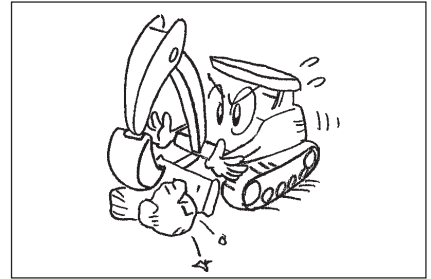

## ▲ CAUTION

As lifting up the machine with the blade, the machine supports with both sides of the blade, not with either side.



## ▲ CAUTION

### Dozer blade.

The dozer blade must not be used as increased stability/support, as no line break safety or mechanical locking device exists.

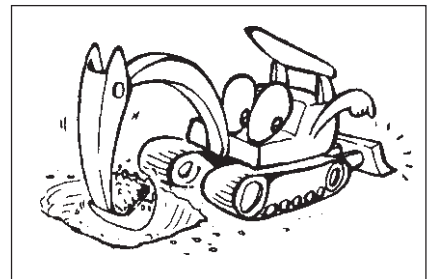

## ▲ CAUTION

### Safety Operation for the usage of hydraulic hammer.

When operating the machine equipped with the hydraulic hammer, avoid as much as possible to operate the hydraulic hammer with each cylinder of arm and bucket in the fully extended position or in the fully retracted position in order to prevent the accidents on each cylinder.

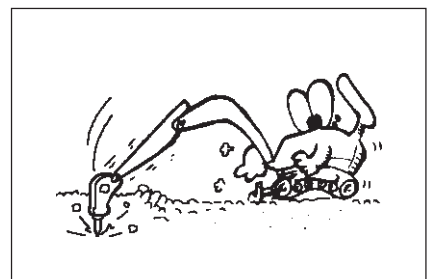

# OPERATIONAL PRECAUTIONS

## OPERATING THE RUBBER CRAWLER

### Do not Travel or Turn on a Sharp Edge or Stepped Grade.

If you travel or turn on a projecting edge or a stepped grade, the machine will put an extra load on the rubber crawler causing it to split or cut the treads of the rubber crawler and the inner steel cord.

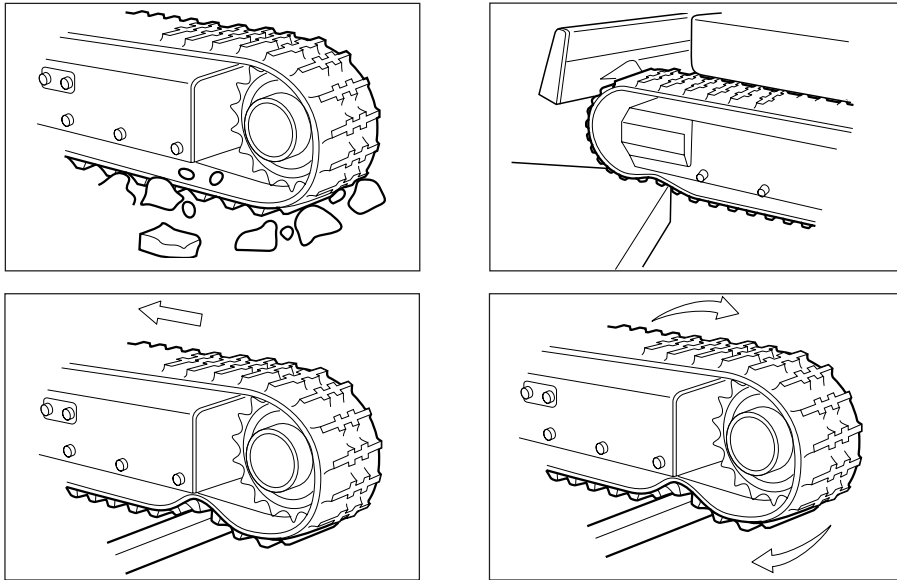

### Prevent Foreign Matter from Entering the Rubber Crawler

Foreign matter will strain the crawler and cut it.

### Make sharp Turns

Do not turn sharply on road with a high-friction factor such as a concrete road.

### Keep Oil Products Away from the Rubber Crawler

If you spill fuel or hydraulic fluid on the rubber crawler, clean it.

### Protection from Salt

Do not operate on a beach. (Core metal will rust due to salt corrosion.)

### Attention to indoor Storage

If the machine is not used for a long time, keep it indoors to prevent exposure to direct sunlight and rain.

#### ⚠ CAUTION

- Be careful to operate the machine with rubber shoes.
- Rubber shoe isn't more stable than steel because of its flexibility.

#### ⚠ WARNING

Even a rubber shoe is easy to slip on frozen or snow surface. Be careful to travel and work under its condition.

#### ⚠ CAUTION

- Driving and slewing on a projecting edge or so cause slacking a rubber shoe to be apt to remove it or cut the inner steel code.
- Driving and slewing with trackroller banked against the rubber shoe is apt to remove the rubber shoe.

# TRANSPORTING BY TRUCK

When loading or unloading the machine on or off a transporting vehicle, use a special platform. If ramps are used, do the following.

## Placing the Ramps

- Use ramps capable of supporting the machine weight. Place them on the transporting vehicle securely.
- The slope angle of the ramps should be between 10° to 15°.
- Place the left and right ramps so that the transporting vehicle center is aligned with the machine center.
- Apply the parking brake of the transporting vehicle and block the front and rear sides each tyre of the transporting vehicle with chocks.

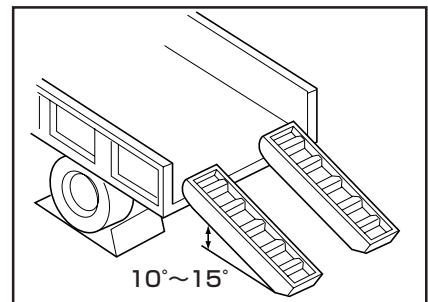

## Going Up and Down the Ramps

- Go up the ramps forward and go down backward slowly.
- Do not turn on the ramps. Align the machine crawlers with the ramps and proceed straight. If the machine is off course when going up the ramps, stop and go back down and try again.

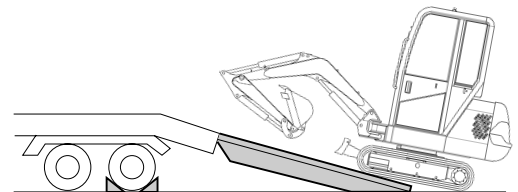

### **⚠ CAUTION**

Before loading or unloading, clean up the ramps. If these are dirty with oil, mud or ice, the machine may slip during loading or unloading.

# TRANSPORTING BY TRUCK

## Fastening the machine

- Swing the machine and park it.
- Lower dozer on the flatbed of transporting machine and bucket on a wooden block with arm and bucket cylinders extending.

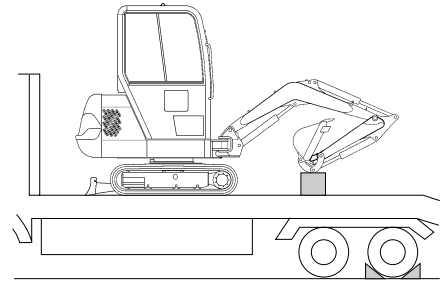

- Turn the key off and remove it.
- Fasten the machine to the flatbed with wire ropes or chains. As fastening, put protectors between track frame and wire ropes or chains.

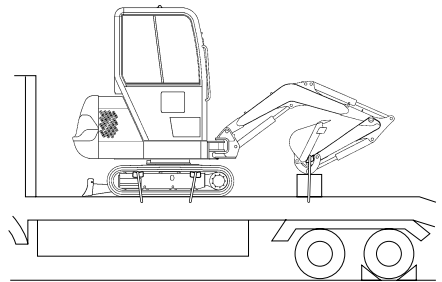

### **⚠ CAUTION**

Be sure to keep the law especially height to the ground and weight of the machine as transporting.

# MACHINE TRACTION

## ⚠ WARNING

- To draw a machine, use a shackle and a wire rope, the strength of which are at least one and a half times as strong as the machine weight. The wire rope must be free from kinks, twists, and breaks.
- While drawing a machine, make sure that no person comes between the tractor and the machine drawn.
- Put the wire rope horizontally, while making it face the track frame straight.
- Draw the traction rope gradually, taking care not to load it abruptly.
- Move the target machine slowly.
- Drawing a machine on a downward slope may let the machine run away out of control. On a bad upward slope, watch the wire carefully.

Always use the traction hook in the back of the bottom frame of the machine drawn.

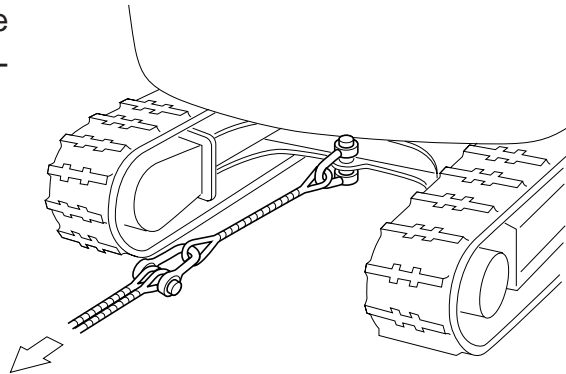

## IMPORTANT

Wire ropes which diameter are more than  $\varnothing 10$  can be used. A shackle must be strong enough to draw the machine.  $\varnothing 10$  or more

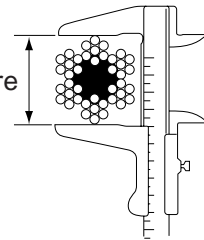

# HOW TO HOIST A MACHINE

## ⚠ WARNING

- The wire ropes for hoisting must be strong enough to lift the machine safely.  
A wire rope not strong enough may break during hoisting a machine, thus letting the machine drop and injure or kill a person.
- For hoisting, choose a flat place and see the "Hoisting Position" and "Machine hoisting procedure" described below. Hoisting a machine while it is not in the Hoisting Position may let the machine unbalanced, causing serious injury or death. Do not hoist a machine while the boom is swinging.

## IMPORTANT

Wire ropes which diameter are more than  $\varnothing 14$  can be used. A shackle must be strong enough to hoisting the machine.

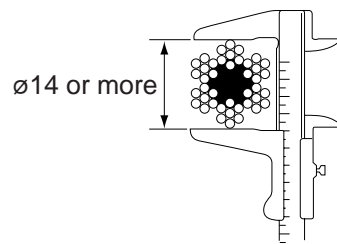

## ⚠ CAUTION

This operation requires the qualification for object handling.

## ⚠ DANGER

Keep other persons away from the machine while it is being lifted.

## Method of hoisting

1. Put the machine into the hoisting position.
  - (1) Raise the blade to the stroke end of the blade cylinder.
  - (2) Operate the swing pedal, get the boom straight, and lock the pedal with the cover.
  - (3) With the control lever, extend the boom cylinder, bucket cylinder, and arm cylinder to their stroke ends.
  - (4) With the slew lever, slew the upper frame, putting the blade in back of the machine and lock with a slew lock pin.
  - (5) Stop the engine, then pull up the lock lever securely to its LOCK position. Get off the machine. Close the door and cover and lock them.

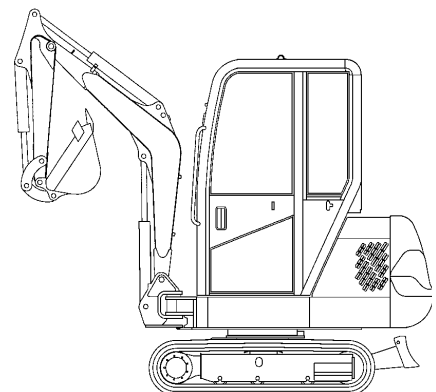

Hoisting position

# HOW TO HOIST A MACHINE

2. Apply a wire rope to the machine, then hoist it.
  - (1) Attach a shackle to each hoisting hole at either end of the blade. Attach a wire rope to the shackles.
  - (2) Attach a shackle to the hoisting hole in the bracket in the middle of the boom.
  - (3) Tension the wire rope lightly with the crane. If the crane is of the cab type, sandwich the waste cloth between the wire rope and the cab, thus protecting the cab.
  - (4) Always level the machine. Make sure that the machine is level and that the crane hook center is near the slewing center of the machine and that the hoisting angle is appropriate. Then hoist the machine.

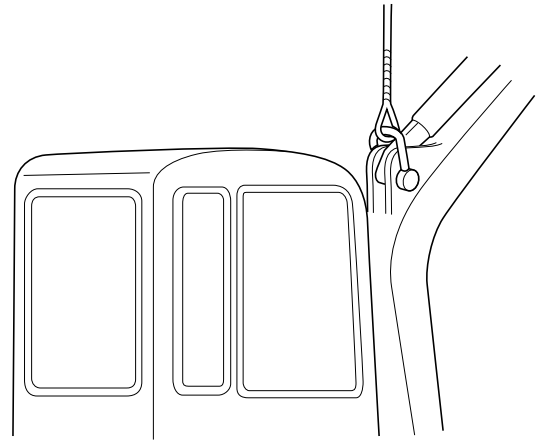
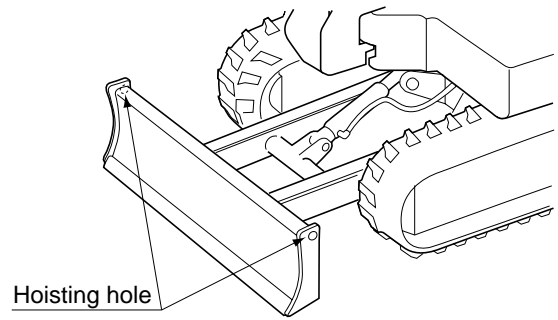

## **▲ DANGER**

The hook holes on the cab are not for hoisting the machine. Hoisting the machine using these holes is very dangerous.

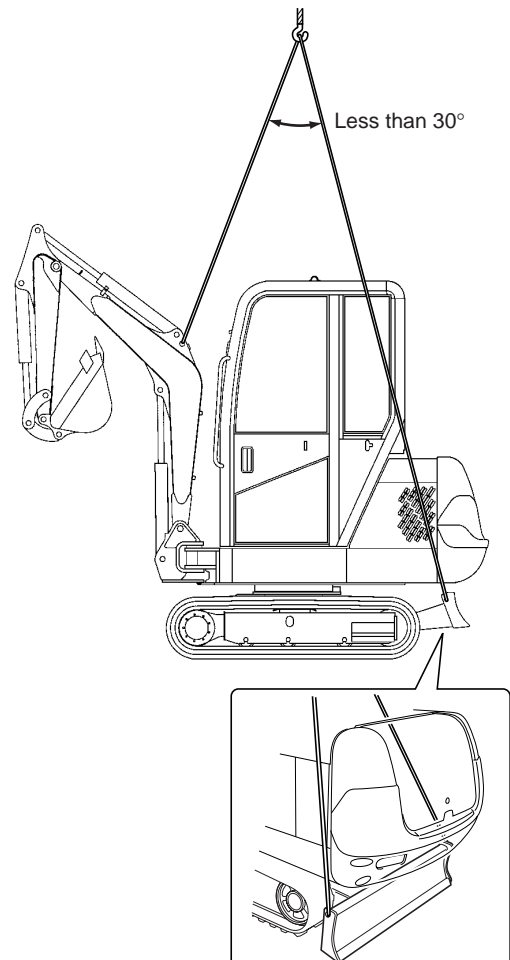

# COLD WEATHER OR DURING-WINTER OPERATIONS

## PRESTART PREPARATIONS

Under the cold weather, engine may be difficult to start and the radiator water and battery fluid may be freezing. Therefore, pay attention to the following matters.

### (1) Lubricant

Engine oil	SAE10W-30
------------	-----------

### (2) Fuel

Use diesel fuel with the pour point five degrees lower than the lowest outdoor temperature.

### (3) Cooling water

Add anti-freeze to the cooling water to prevent the cooling system from freezing. The following table shows the freezing temperatures by the amount of added anti-freeze.

 The total quantity of cooling water is 5.6 ℓ including overflow tank.

The machine is filled with the anti-freeze for -20°C when transported from the factory.

Lowest temperature (°C)	-5	-10	-15	-20	-25	-30
Amount of anti-freeze (ℓ)	1.3	1.6	2.0	2.3	2.7	3.2
Amount of cooling water (ℓ)	4.3	4.0	3.6	3.3	2.9	2.4

### CAUTION

Be careful with fire because anti-freeze is flammable.

### WARNING

Supply the additional cooling water just before the start of operation not after the finish of operation in a day to prevent freezing.

 For details refer to page 65.

# COLD WEATHER OR DURING-WINTER OPERATIONS

## 4) Battery

Under low temperatures, battery capacity becomes low. If charging voltage is insufficient, the battery fluid might be frozen. In this case, cover the battery with cloth or keep the battery in a warm place. Reinstall it in the morning.

※ **The charging rate is as shown below.**

Fluid temperature Charging rate	20°C (68°F)	0°C (32°F)	-10°C (14°F)	-20°C (-4°F)
100%	1.28	1.29	1.30	1.31
90%	1.26	1.27	1.28	1.29
80%	1.24	1.25	1.26	1.27
75%	1.23	1.24	1.25	1.26

### ⚠ WARNING

If the battery is recharged using a booster cable, make sure that earthing wire is attached and engine stopped. Remove the fluid cap and connect the cable to the battery.

### ⚠ CAUTION

Be careful not to stain your hands and eyes because deluted sulfuric acid is used as electrolyte.

### ⚠ WARNING

- When disconnecting the terminals, start with ⊖ terminal. When connecting them, connect ⊖ terminal last.
- When using a tool near the battery, be sure not to contact ⊕ terminal because the machine's body is ⊖.

# LONG-PERIOD STORAGE

## 1. Before Storage

- (1) If you don't use the machine for a long time, clean up and inspect the machine, grease or lubricate the spring guide, spring, yoke slide and exposed portions of the cylinders sufficiently to prevent rusting.

### IMPORTANT

- If you leave the machine outdoors park it on wooden planks on a level ground (concrete floor) and cover with sheet.
- If you don't use the machine for a long time, disconnect the battery cable (-) side or recharge to prevent the battery from being discharged.

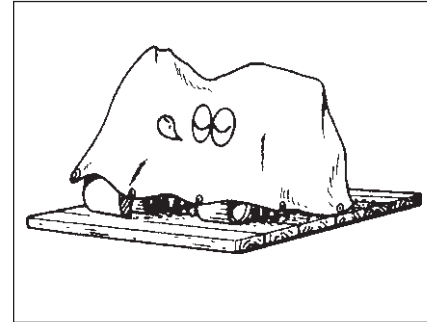

## 2. During Storage

- (1) Operate engine at least once a month to lubricate engine and hydraulic parts. After this, grease or lubricate exposed portions of the cylinders.
- (2) Recharge the battery at the same time.
  - ☞ For details, refer to page 44.

### ⚠ WARNING

In case indoors, pay attention to the ventilation. Start engine with all windows fully opened.



## 3. After Storage

- (1) Before starting the engine, check the engine oil, hydraulic oil and water level.
- (2) To start engine keep the starter switch "ON" position to feed sufficient fuel to the chamber. Wait for 1 minute then turn to "START" position to warm up the engine.
- (3) Operate the cylinders three or four times at low engine speeds.

### ⚠ WARNING

Sudden operations may damage the packings.

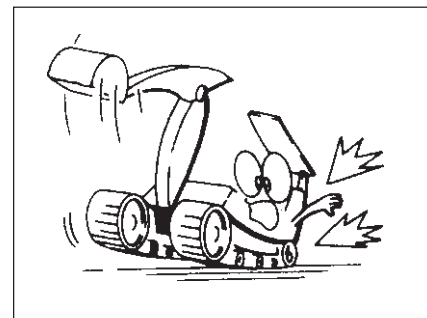

# **INSPECTION AND MAINTENANCE**

# ORDERING PARTS AND SERVICING GUIDELINES

## Order of Parts

Inform the dealer the part name, the part number and machine's serial No.(SER.No.) when ordering parts.

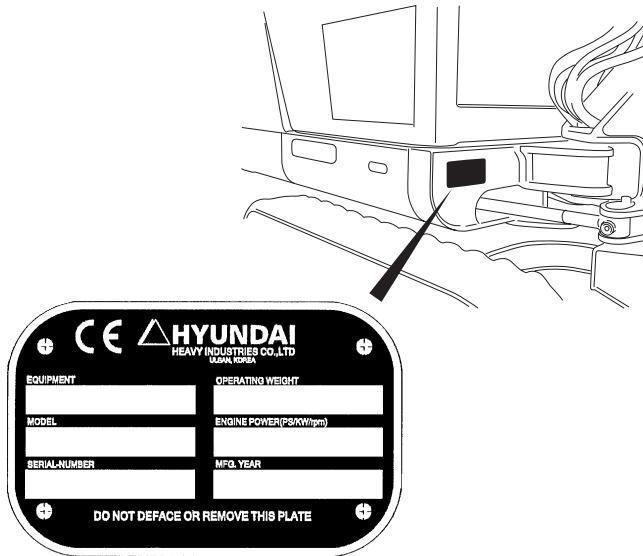

## Troubleshooting

Inform the dealer the type name, serial number (SER.No.) and accumulated operation hours on the hour meter.

Use the hour meter as follows.

- Write down the values before and after the operation in the daily report.
- The hour meter indicates when to replace the filter and oil.

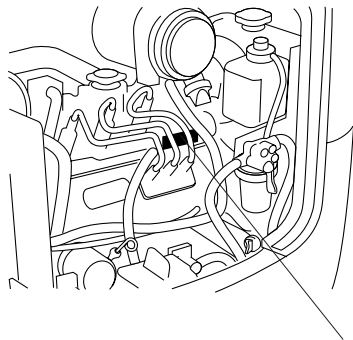

Engine No. (identification plate)

# INSPECTIONS

Do the following inspections. Neglecting any of the inspections may result in trouble with the machine including the hydraulic equipment.

## Prestart Inspections

Check the following items before operation everyday.

### ⚠ CAUTION

- For inspection, always park the machine on level ground.
- Keep other persons away from the machine while inspecting it.
- Before inspection and maintenance, be sure to stop the engine.

1. Checking the amount of oil in the engine oil pan.  
Pull out the dipstick Wipe the oil off the dipstick using a cloth and insert it again.  
If the oil amount is insufficient, add engine oil through the oil port.

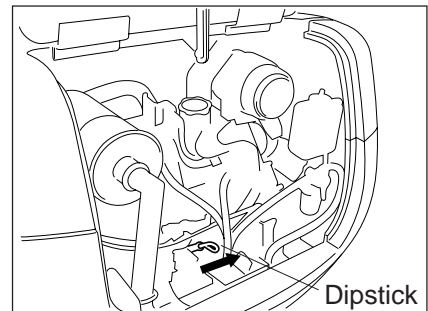

### IMPORTANT

Use high-quality engine oil. It is recommended to use the following engine oils.

	Engine oil	SAE10W-30
	Capacity	MAX. 3.5 ℓ

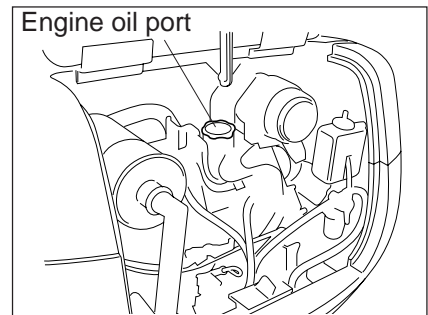

### ⚠ WARNING

- Do not inspect engine oil level after stopping the engine immediately. Engine oil is so hot that it is dangerous and it takes 30 minutes that the engine oil thoroughly flows down the crankcase. Inspect it before working or after 30 minutes after the engine has stopped.
- Take care not to add too much engine oil.
- Check that the engine oil level 30 minutes after replenishment.

### IMPORTANT

Also check the sample oil on the dipstick for fouling and degrees of viscosity.

### ⚠ CAUTION

In adding oil, take care not to spill it. If you spill oil, wipe it properly, or this could lead to fire and the risk of personal injury and equipment damage.

# INSPECTIONS

## 2. Checking the amount of water in radiator

Confirm the level of water in overflow tank at the specified level or more without removing the radiator cap. If it is insufficient, add soft water (tap water) to the tank.

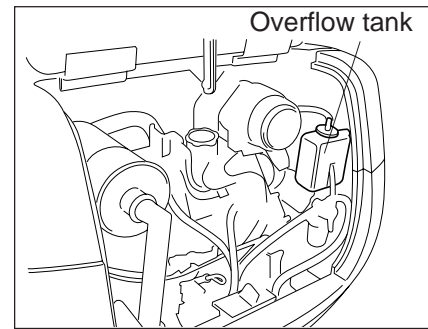

### **⚠ CAUTION**

- Do not use dirty water to prevent clogging of the fins.
- The radiator cap must not be taken off when the temperature of cooling water is high. The water will be very hot and could cause injury if released before cooled.

## 3. Checking the amount of oil in the hydraulic oil tank

Make sure that the hydraulic oil level is past the center of the level gauge. If the amount is insufficient, add oil and pressurize the hydraulic oil tank.

📖 For details refer to page 61.

**B** Level gauge reading 24ℓ when topping-up, use top-up hole.

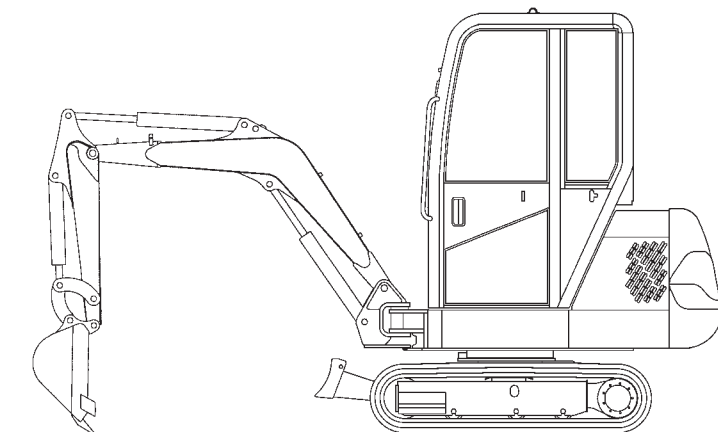
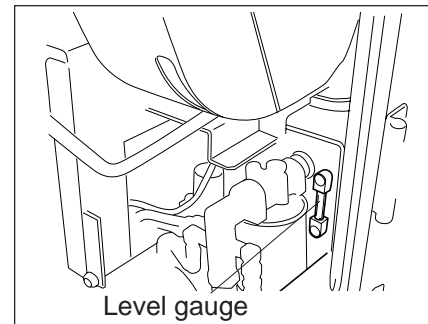

### **⚠ CAUTION**

It is dangerous to inspect the oil level in the hydraulic oil tank after stopping the engine immediately. The hydraulic oil is too hot.

# INSPECTIONS

## 4. Checking the amount of fuel in the fuel tank

Make sure the fuel level with the level gauge at the monitor panel. If the amount is insufficient, add diesel fuel.

 Level gauge reading 20 ℓ .

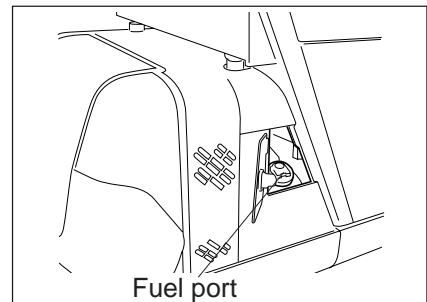

### CAUTION

Do not expose the fuel to flame or spark because the diesel fuel is flammable.

This could lead to a fire and the risk of personal injury and the machine damage.

### IMPORTANT

The fuel indicator on the fuel tank doesn't move until the fuel level is close to full. This is for the confirmation.

## 5. Checking the water separator

- (1) Water is collected in the water sedimentor in which the float will transmit it to the pointer.
- (2) Remove the water sedimentor element by unscrewing.

### IMPORTANT

After cleaning or replacing, the contained air should be bled.

 For details refer to page 63.

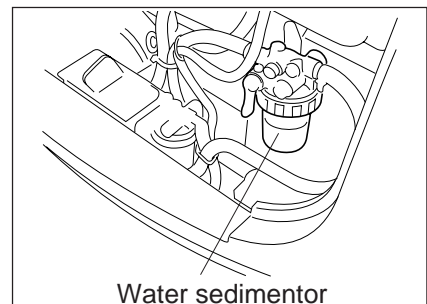

### CAUTION

If you spill fuel, wipe it properly, or this could lead to a fire and the risk of personal injury and equipment damage.

# INSPECTIONS

6. Checking the loose parts  
Check each part for looseness.  
Carefully inspect the crawlers, track rollers, sprockets and drive motor.

**N-m** **Tightening torque**

Nut of track roller	<b>N-m</b>	120
Sprocket mounting position	<b>N-m</b>	72
About pin of attachment	M8 <b>N-m</b>	30
	M10 <b>N-m</b>	72
	M12 <b>N-m</b>	120

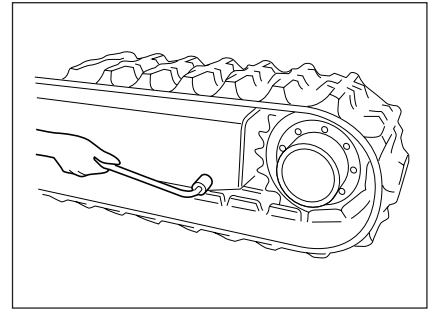

7. Checking the fan belt  
Check the belt for 13 mm of slack by pressing at midway between the alternator and crankshaft pulley with the thumb and for breakage.

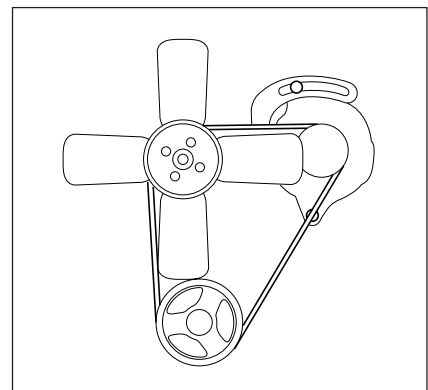

**CAUTION**

When you find sludge or so on the fan belt you have to replace it with new one.

**IMPORTANT**

When the fan belt tension is too high, it will result in bearing failure of alternator and waterpump. Contrarily, loose belt will cause belt slippage which may result in damaged belt, abnormal noise and overheat.

# INSPECTIONS

## Tightening Torque List

At prestart inspections, always check the bolts and nuts for looseness. If any bolt or nut is loose, retighten according to the table below.

⬡ N-m ⬡ Tightening torque of the bolt and nut (Body)

Material Size	8.8 N-m	10.9 N-m	12.9 N-m
M6	12.5	16	20
M8	30	39	45
M10	62	72	80
M12	100	120	130
M14	160	195	220
M16	250	305	340

⬡ N-m ⬡ Tightening torque of the hydraulic pipings

PT screw

Torque Size	N-m
$\frac{1}{4}$	36
$\frac{3}{8}$	55
$\frac{1}{2}$	86
$\frac{3}{4}$	130
1	195
$1\frac{1}{4}$	300
$1\frac{1}{2}$	400

PF screw

Torque Size	N-m
$\frac{1}{4}$	27-30
$\frac{3}{8}$	47-52
$\frac{1}{2}$	57-63
$\frac{3}{4}$	108-120
1	126-140

# MAINTENANCE AFTER THE FIRST 50 SERVICE HOURS (NEW MACHINE)

## 1. Replacing engine oil filter cartridge

- (1) Warm up the engine (for about 10 minutes), as the engine oil should be warm before replacing the cartridge.
- (2) Remove the drain plug of the oil pan, and drain the oil.

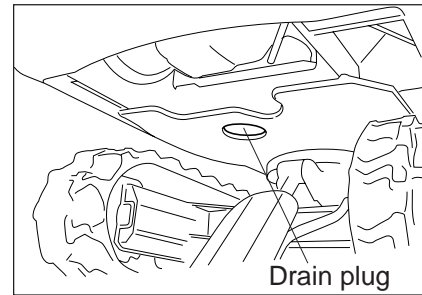

- (3) Remove the cartridge with a filter wrench.
- (4) Slightly coat the O-ring of the new cartridge with oil and firmly tighten the cartridge by hand.

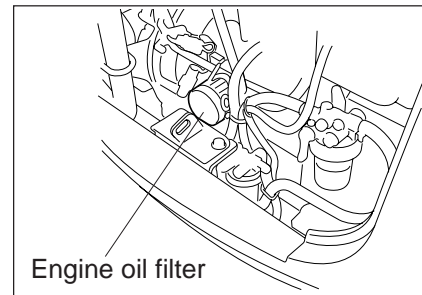

- (5) Securely replace the drain plug, and add the specified amount of new engine oil through the oil supply port.
- (6) Start and idle the engine for several minutes to check for oil leakage. After the engine is stopped, check the oil level using the level gauge. If short, add oil.

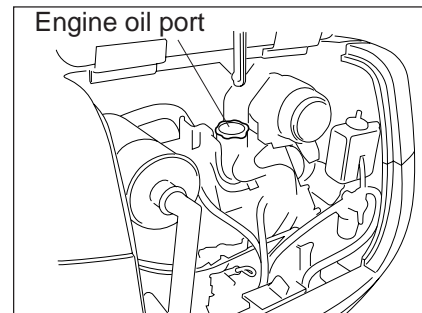

3 3.5 ℓ

### ▲ CAUTION

- Perform this operation on level ground. Make sure that dust does not enter through the oil supply port.
- It takes 30 minutes that poured oil flows down the crankcase. As checking the oil level, wait for 30 minutes.

# MAINTENANCE AFTER THE FIRST 100 SERVICE HOURS (FOR NEW MACHINE)

1. Replacing the line filter element  
Remove the filter with a filter wrench and replace it with new one.

## IMPORTANT

Before replacing the filter, be sure to open the hydraulic oil tank to bleed the filter.

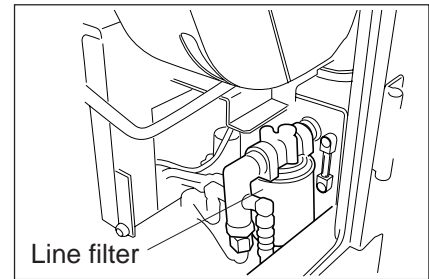

2. Cleaning the pilot filter  
Remove the plug from under the floor plate with a wrench (width across flats:27 mm) and pull out the element.  
Clean the element with cleaning oil and remove all dirt.

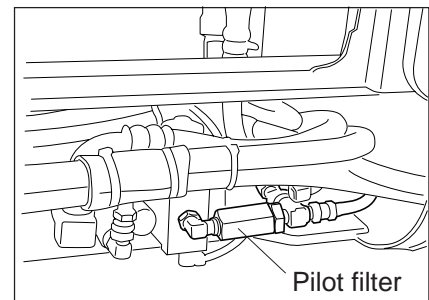

3. Cleaning the suction filter  
Remove the suction filter from the hydraulic oil tank. Clean the filter with diesel fuel or kerosene to remove the dirt. If the strainer is broken, replace it with new one.

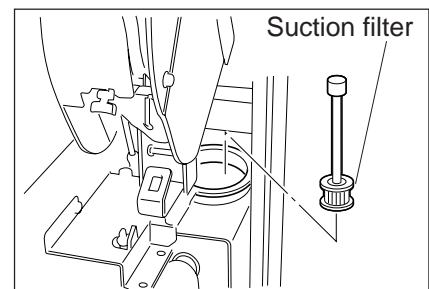

## IMPORTANT

To reinstall the lid, set the O-ring securely into the flange groove in order to prevent a leak of hydraulic oil.

## CAUTION

Do not perform this operation while the hydraulic oil is still hot, to avoid being burned.

# MAINTENANCE EVERY 50 SERVICE HOURS

(PERFORM THE MAINTENANCE AT THE SAME TIME IF IT IS CONTAINED IN THE DAILY MAINTENANCE.)

Perform the following maintenance after the first 50 service hours.

1. Cleaning the radiator fins  
Clean the radiator fins using pressurised air and steam.

## **⚠ WARNING**

If the fins remain dirty, the engine will overheat.

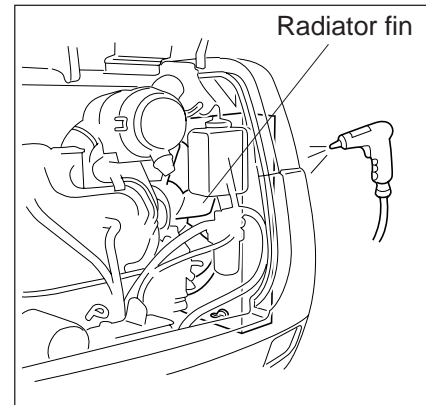

2. Checking the amount of battery electrolyte  
Loose the bolt which fix the battery cover to take out the battery.  
The color of the indicator on the battery shows battery's condition. Blue is OK. Red is necessary to charging. White is necessary to add distilled water.  
(1) Visually check whether the level of the battery electrolyte in each block is between the upper and lower limits.  
(2) If it is under the lower limit, take off the cap to add battery electrolyte or distilled water to the upper limit in each block.

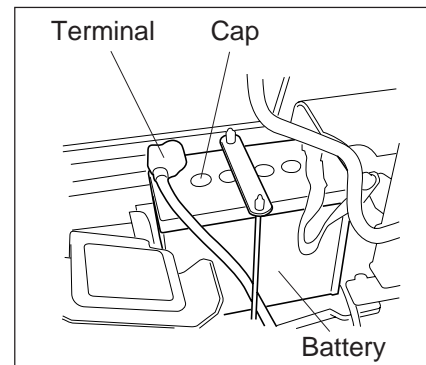

## **⚠ CAUTION**

- When inspecting the batteries, be sure to stop the engine.
- When dealing with the batteries, you must put on a protect glasses.
- Deluted sulfuric acid as electrolyte is dangerous substance. Be careful not to strain your eyes, hands, clothes and metals. If it gets in your eyes, wash with a large amount of water at once. Then go and see a doctor.
- As highly flammable hydrogen gas is rising from the batteries, do not make a spark or use fire in any other way near the batteries.
- When disconnecting the terminals, start with  $\ominus$  terminal. Contrarily, when connecting them, connect the  $\ominus$  terminal last.

## MAINTENANCE EVERY 50 SERVICE HOURS

3. Inspecting the specific gravity of the fluid  
Measure the specific gravity of the electrolyte. If it is lower than the specified values, recharge the battery. At this time, clean and connect the terminals, and then coat with grease.

### ⚠ CAUTION

- Always stop the engine while the work.
- Do not coat with grease before connecting the terminals.

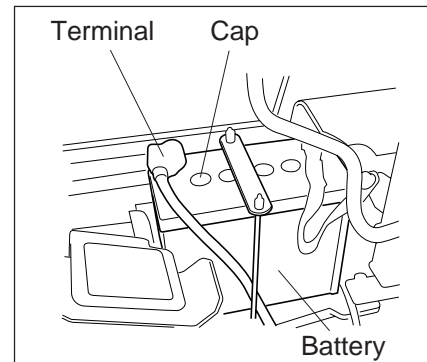

4. Greasing slew bearing  
Use a grease gun to lubricate the grease nipples of screw bearing.

### ⚠ WARNING

After working in water, give grease without fail.

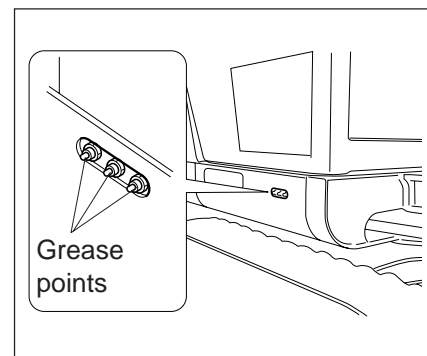

5. Eliminating the sediment in the fuel tank  
Open the drain cock to eliminate the sediment and drain the water.

### IMPORTANT

It is effective to do this before starting the engine.

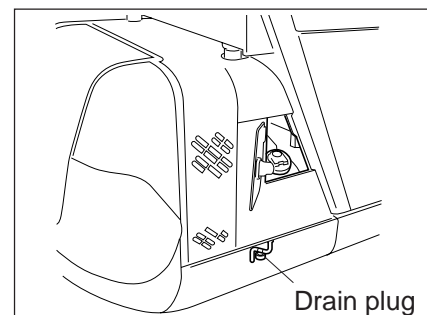

6. Checking the fuel tank strainer  
Remove the tank cap, remove any loose dirt on the strainer and clean it with diesel fuel.

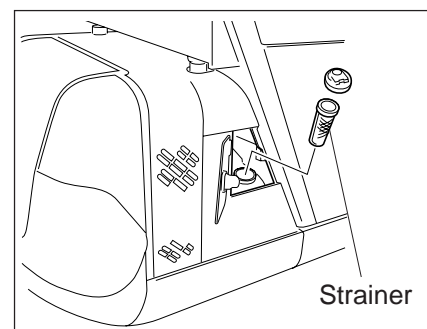

# MAINTENANCE EVERY 100 SERVICE HOURS

1. Inspecting and cleaning the air cleaner  
Clean the dust-cover. Inspect and clean the element.  
☞ For details refer to page 64.

## **⚠ WARNING**

After stopping the engine, clean them.

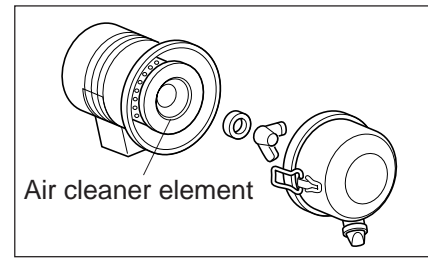

2. Cleaning the fuel filter element.  
You can take out the element by removing the filter ring nut. Clean the filter with diesel fuel.

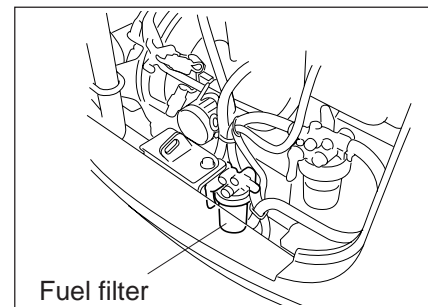

# MAINTENANCE EVERY 250 SERVICE HOURS

## 1. Replacing engine oil filter cartridge

- (1) Warm up the engine (for about 10 minutes), as the engine oil should be warm before replacing the cartridge.
- (2) Remove the drain plug of the oil pan, and drain the oil.

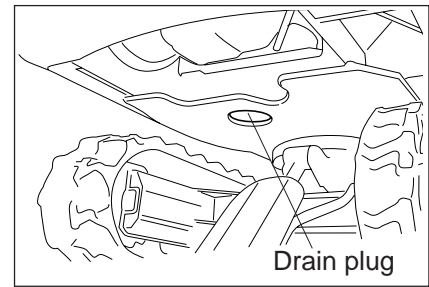

- (3) Remove the cartridge with a filter wrench.
- (4) Slightly coat the O-ring of the new cartridge with oil and firmly tighten the cartridge by hand.

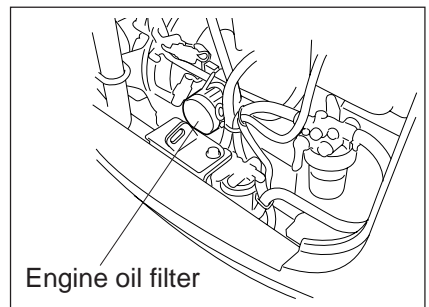

- (5) Securely replace the drain plug, and add the specified amount of engine oil through the oil supply port.
- (6) Start and idle the engine for several minutes to check for oil leakage. After the engine is stopped, check the oil level using the level gauge. If short, add oil.

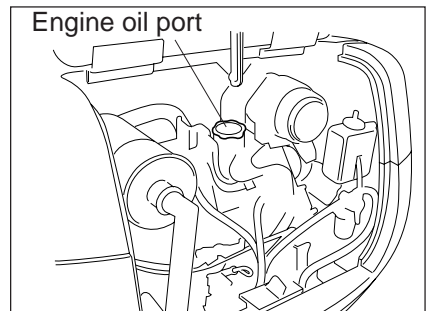

 3.5 ℓ

### IMPORTANT

Perform this operation on level ground. Make sure that dust does not enter through the oil supply port.

## 2. Eliminating the sediment in the hydraulic oil tank

Open the drain plug to eliminate the sediment and drain the water.

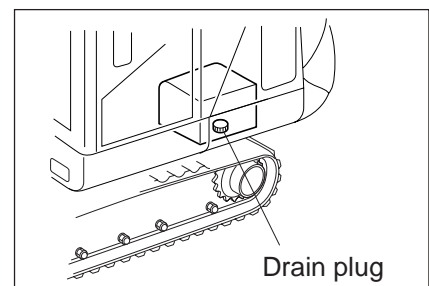

### CAUTION

It is dangerous to open the cap on the hydraulic tank after stopping the engine immediately, because the hydraulic oil is too hot.

# MAINTENANCE EVERY 500 SERVICE HOURS

1. Replacing the fuel filter element  
You can take out the element by closing the cock and removing the retainer ring.  
Replace it with new one.

## ⚠ CAUTION

O ring must be replaced with new one in this time.  
After replacing the element, bleed air.

📖 For details refer to page 63.

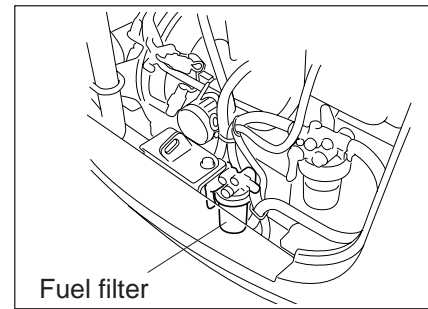

2. Replacing cooling water in radiator  
Remove the drain plug on radiator to replace the cooling water.

📦 5.6 ℓ

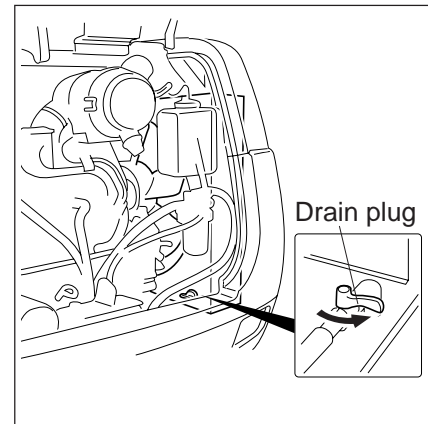

3. Cleaning the suction filter  
Remove the suction filter from the hydraulic oil tank. Clean the filter with diesel fuel or kerosene to remove the dirt. If the strainer is broken, replace it with new one.

## IMPORTANT

To reinstall the lid, set the O-ring securely into the flange groove in order to prevent a leak of hydraulic oil.

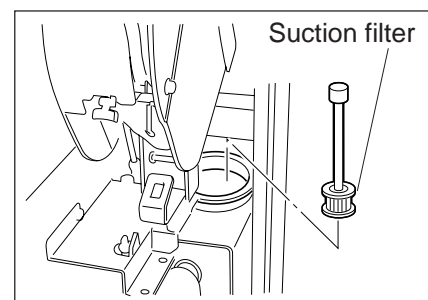

## ⚠ CAUTION

Do not perform this operation while the hydraulic oil is still hot to avoid being burned.

4. Replacing the line filter element  
Remove the filter with a filter wrench and replace it with new one.

## IMPORTANT

Before replacing the filter, be sure to open the hydraulic oil tank to bleed the filter.

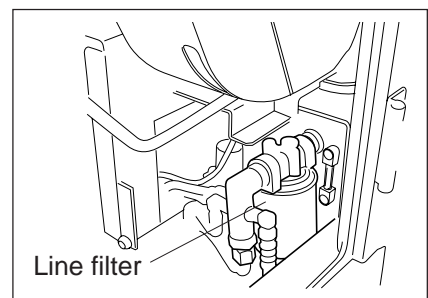

## MAINTENANCE EVERY 500 SERVICE HOURS

### 5. Cleaning the pilot filter

Remove the plug from under the floor plate with a wrench (width across flats: 27mm) and pull out the element.

Clean the element with cleaning oil and remove all dirt.

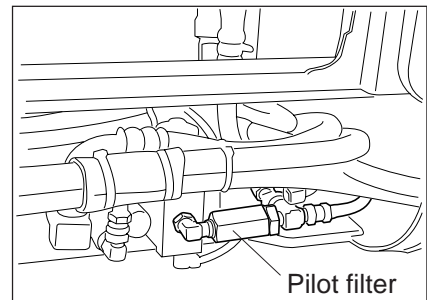

### 6. Replacing air cleaner element

Clean a dust-cover. Replace elements.

☞ For details refer to page 64.

#### **⚠ WARNING**

After stopping the engine, clean them.

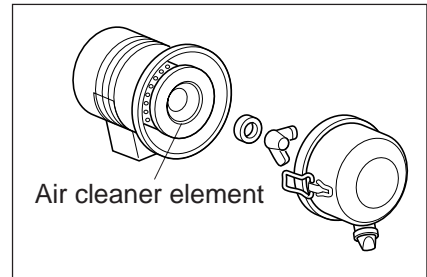

# MAINTENANCE EVERY 1000 SERVICE HOURS

## 1. Cleaning the Cooling Water Passage

Clean the inside of the radiator and the engine water passage.

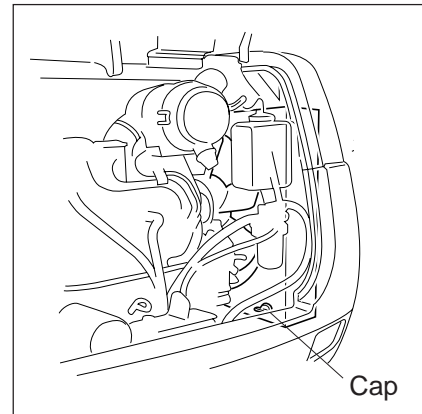

## 2. Replacing the Hydraulic Oil

Remove the drain plug and replace all hydraulic oil.

**3** Amount of hydraulic oil: 24 ℓ

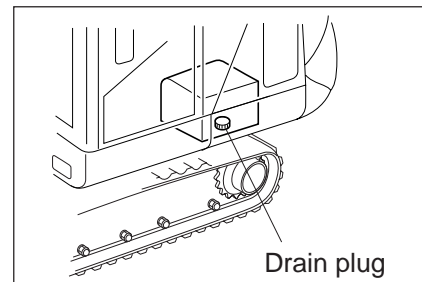

## 3. Replacing the Lubricating Oil in the Travel Speed Reduction Gear.

Remove the blind plug in the speed reduction gear cover, and replace the lubricating oil.

# TO PRESSURIZE

1. It is necessary to pressurize the hydraulic oil tank in case of the following :
  - (1) When the cover or the plug on the hydraulic oil tank is removed, due to some reason.
  - (2) When the hose is removed from the hydraulic circuit for the repair or check, due to oil leakage or others.
  - (3) When the major component is exchanged, or others.
  
2. Purpose  
It is easier for the hydraulic pump to suction the oil.  
(Suction pressure of the pump should not have the negative pressure.)
  
3. Procedure
  - (1) Remove the cover of the hydraulic oil tank. If the machine has a plug on it, it is advisable to remove only the plug.
  - (2) Start the engine and extend all cylinders as the Figure 2.  
\*Hydraulic oil go to the cylinders to be the lowest oil level in the tank.
  - (3) At the condition of ii), tighten the cover or plug of the tank.  
\*Work with your caution, the dozer cylinder is also extended at maximum stroke.  
After this work and machine is operated, the oil in the cylinder go back to the tank.  
And then, the oil level in the tank is increased, inside the tank is pressurised.

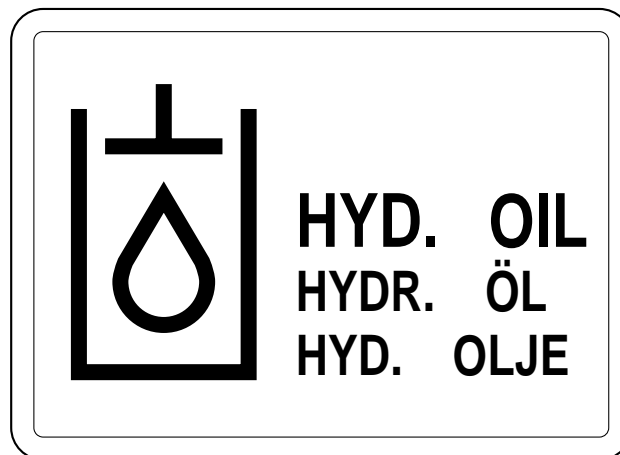

This label on the side cover. PART No. 11240-11960

Figure 1

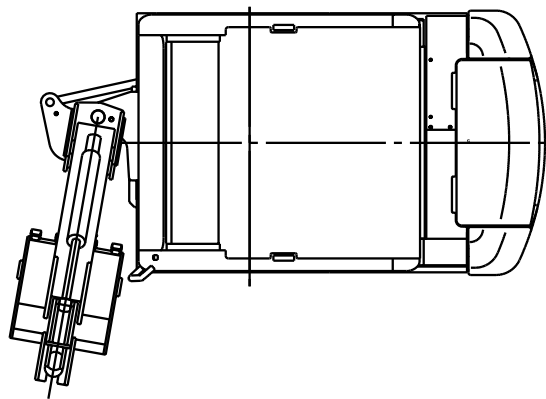
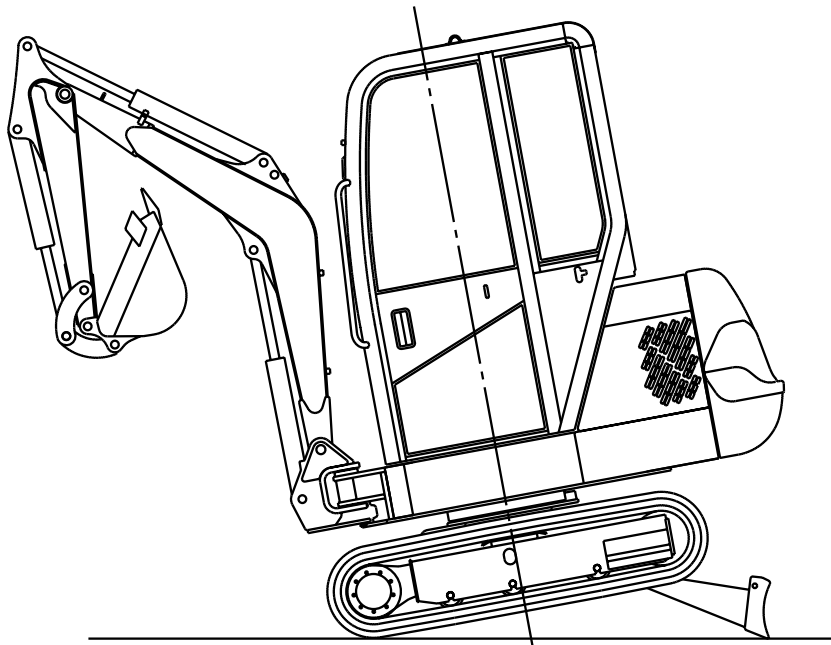

Figure 2

# INSPECTION AND MAINTENANCE PROCEDURES FOR ENGINE PARTS

## Air bleeding of fuel system

After cleaning the fuel filter or the water sedimentor, replacing the element or using up the fuel, bleed the air in according to the following procedure.

- (1) Fully fill the fuel tank.
- (2) Open the cock of fuel filter.
- (3) Turning the starter switch ON automatically bleeds the air.

**IMPORTANT**

The air can ordinarily be bled in about one minute when the fuel filter is empty.

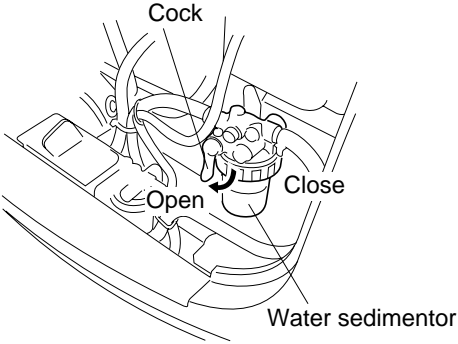
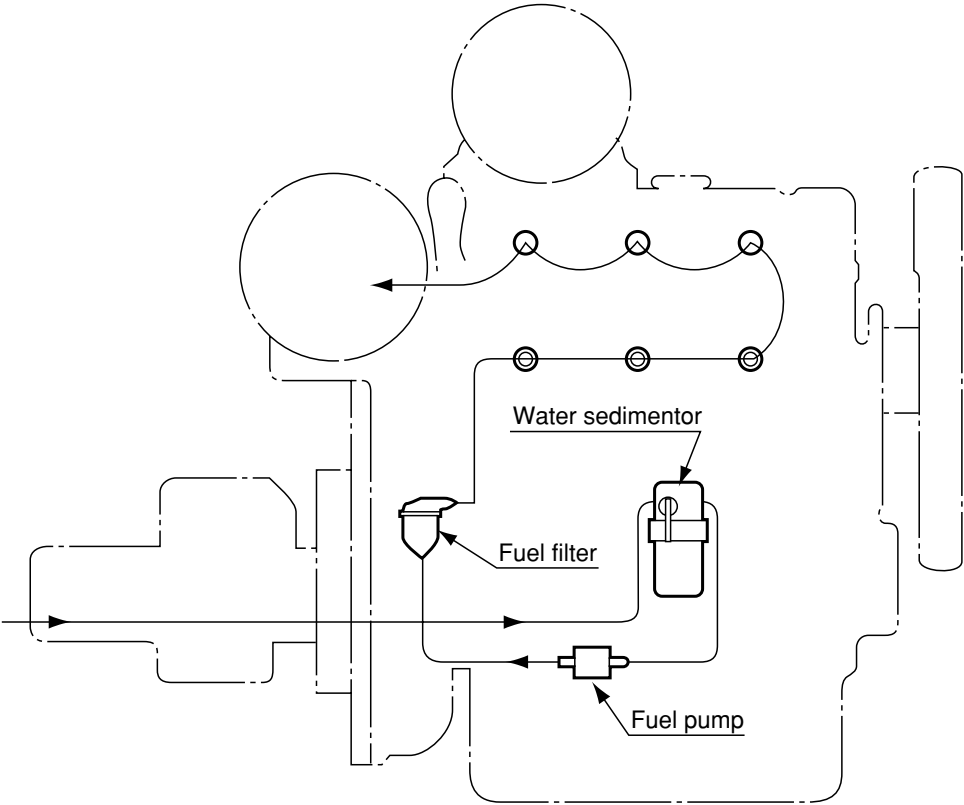

# INSPECTION AND MAINTENANCE PROCEDURES

## 1. AIR CLEANER ELEMENT

By loosening the air cleaner band, and check the contamination of the element visually.

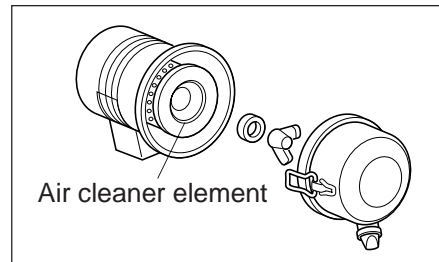

### Inspection

The inspection method varies depending on how dirty the element is.

- (A) If dry dust is adhering to the air cleaner element, blow pressurized air ( $7\text{kg/cm}^2$  (2.4psi) or less) from inside of the air cleaner element to remove it.
- (B) If the element is soiled with black carbon or soot, remove it with cleaning liquid.
  - (1) For the cleaning liquid, dissolve 300g (10.6oz) of air element cleaner (ND1500) into 20ℓ of water. Immerse the air cleaner element for about 20 minutes.
  - (2) With the dust cap removed, flush the air cleaner element using tap water.
  - (3) After cleaning, let the element dry in a place where air circulates freely.

The standard inspection is every 100 service hours. However, inspect every 50 if the machine is used in a dusty environment.

### **⚠ WARNING**

Never use fire or pressurized air to dry the air cleaner element.

# INSPECTION AND MAINTENANCE PROCEDURES

## 2. THE COOLING WATER

Dirt and rust in the water decreases the effectiveness of the cooling system.

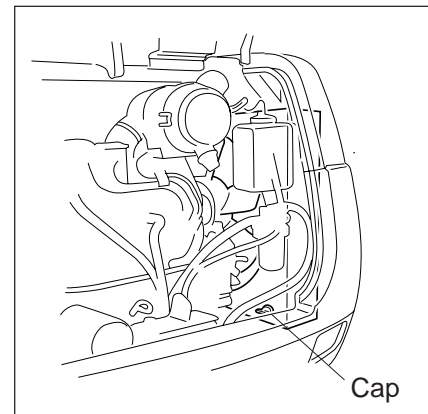

### Replacement

- (1) Remove the radiator cap and open the drain plug to drain the cooling water.
- (2) Close the drain plug and fill the radiator with cleaning fluid. (\*1).
- (3) Open the radiator drain plug while feeding fresh water through the radiator cap. Continue this until the clean water comes out.
- (4) After clean water comes out, close the plug, feed the neutralization fluid (\*2) and start the idling for 5 minutes.
- (5) Stop the engine and open the drain plug to clean the inside of radiator with water.

Close the drain plug and supply cooling water to the specified level.

Cleaning fluid (\*1): dissolve Sodium bisulfite of 250g in water of 1 ℓ.

Neutralization fluid (\*2): dissolve Sodium carbonate of 6g in water of 1 ℓ.

### ⚠ WARNING

Anti-freeze should be fully mixed with the water in another vessel prior to feeding it in the radiator. If you do not follow the above, overheating may occur.

### ⚠ DANGER

It is very dangerous to remove the radiator cap just after stopping the engine. If you want to remove the cap, slowly turn the cap to gradually release the internal steam pressure.

### ⚠ CAUTION

Cooling water is harmful substance. Deal with it appropriately when it is dumped.

# INSPECTION AND MAINTENANCE PROCEDURES

## 3. INSPECTING CRAWLER TENSION

Unequal tensions of the crawlers may cause the machine to deviate from the travelling path. Make sure the crawlers are equally tensioned. Always adjust the tension of the rubber crawler after the first 10 to 20 service hours.

- (1) If crawler is too tight, the rolling friction on the surface idler sprocket contacting with the bearing increases, scoring occurs on the crawler link pin and the resistance is increased, resulting in the reduction of travelling ability.
- (2) If the crawler is too slack, it may slip off the sprocket. Resistance increases when going in reverse and the travelling ability of the machine is reduced.

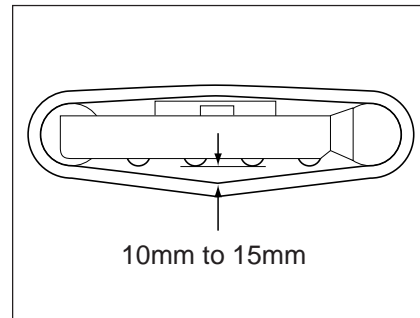

### Inspection

- (1) Insert a grease gun into the grease nipple and pour the grease to strain the crawler.
- (2) For loosening the crawler, loosening the cartridge valve, the grease in the cylinder automatically comes out.

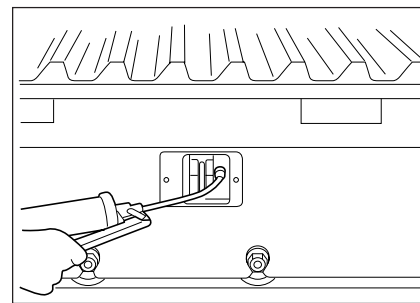

### \* Confirmation of inspection (checking for air locks)

Before straining the crawler, loosen the cartridge valve and make sure grease comes out by pushing the front idler to the cylinder. Then tighten the valve and add grease again.

# INSPECTION AND MAINTENANCE PROCEDURES

## 4. TRAVELLING MOTOR

Use the recommended lubricant for the reduction gear.  
 If a different brand is used, replace all lubricant with new brand.

☞ Engine oil SAE30-CD or equivalent is used at the time of shipment

First replacement of lubricant	500 Hr
Second or following replacement	1000 Hr
Amount of lubricant	250 cc

☞ For the recommended lubricant and grease, refer to the list on page 78.

### Replacement

The cover is provided with two blind plugs. With the cover set vertically against the ground as shown in the figure, the centre port is for inspection, and the bottom port for draining and supplying in case it is the top.

- (1) Turn the motor so that the supply/drain port is the bottom of the motor.
- (2) Remove the supply/drain plug and center plug to drain the oil.
- (3) Turn the motor so that the supply/drain port is the top of the motor.
- (4) Fill the oil through the supply/drain port.
- (5) Clean plugs and wrap their threads with sealing tape and retighten them.

⬡ N-m Tightening torque:36N-m(27 lb-ft)

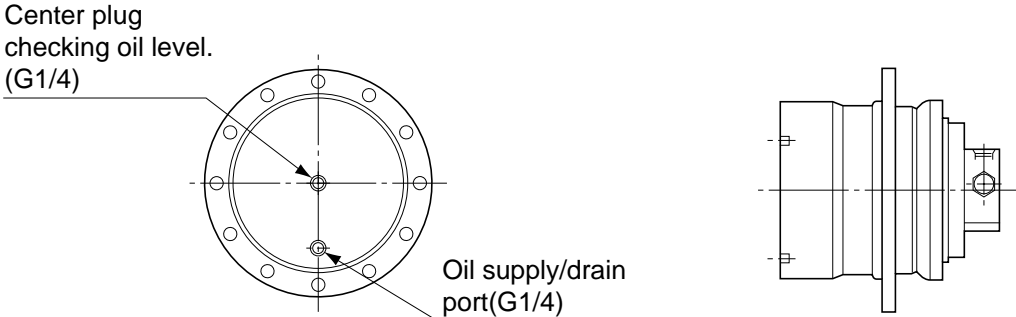

# PERIODICAL INSPECTIONS AND MAINTENANCE LIST

○ Inspect, Add, Adjust, Grease    △ Clean    ⊙ Replace

Period		Check before start-up	First 50 hours	First 100 hours	Every 50 hours	Every 100 hours	Every 250 hours	Every 500 hours	Every 1000 hours	Every 2000 hours	Remarks	Refer to
Engine	Inspecting an abnormal exhaust noise from engine	○										
	Inspecting and replacing engine oil	○	⊙				⊙					
	Replacing engine oil filter cartridge		⊙				⊙					
	Adding fuel and cleaning fuel tank	○			* △						*Drain water and sediment	
	Cleaning and replacing fuel filter element					△		⊙				
	Inspecting water sedimentor	○						△				
	Adding and replacing cooling water	○							* ⊙		*Replace every spring and autumn	
	Cleaning radiator fin				△							
	Inspecting, cleaning and replacing air cleaner element					△		⊙				
	Inspecting and adjusting tension of fan belt	○										

# PERIODICAL INSPECTIONS AND MAINTENANCE LIST

○ Inspect, Add, Adjust, Grease    △ Clean    ⊙ Replace

Period Item		Check before start-up	First 50 hours	First 100 hours	Every 50 hours	Every 100 hours	Every 250 hours	Every 500 hours	Every 1000 hours	Every 2000 hours	Remarks	Refer to
Attachment	Inspecting the bolt and nut for tightness	○										
	Inspecting and greasing the attachment pins	○										
	Check for loose parts and damaged parts	○										
	Greasing the slew bearing gear				○							
	Inspecting the crawler tension (grease cylinder)	○										
	Inspecting and greasing the lower roller					○				⊙		
	Replacing the lubricant for the crawler drive unit reduction gears									⊙	First 500 hours	
Hydraulic system	Inspecting the joint for looseness and oil leaks	○										
	Supplying or replacing the hydraulic oil	○					* △		⊙		*Drain water and sediment	
	Replacing the line filter element			⊙				⊙				
	Cleaning or replacing the suction filter			△				△		⊙		
Electric system	Check wiring for non-connection short circuit, loose connections	○										
	Inspecting the electrical parts	○										
	Inspecting the battery fluid level				○							

# LUBRICANTS

Use the oil and grease specified in the table below depending on the seasons.

**Table of Recommended Lubricants**

NO.	LUBRICANT	CASTROL	ESSO
1	Engine Oil	RX SUPER 10W-30	LUBE MHX 10W-30
2	Gear Oil	EPX 85W-140	GX 85W-140
3	Hydraulic Oil	HYSPIN AWH-M-46	UNIVIS N46
4	Cup Grease	SPHEEROL LEP-2	BEACAN EP 2
5	Antifreeze	Anti Freeze	Anti Freeze
6	Diesel Fuel	—	—

\* The engine oil SAECD10W-30 or equivalent at the time of shipment is used for the lubricating oil for travelling speed reducer.

\* German Hydraulic oil is Univis J32.

# LUBRICANTS

## Grease Supply Points - Main Frame

How to read table

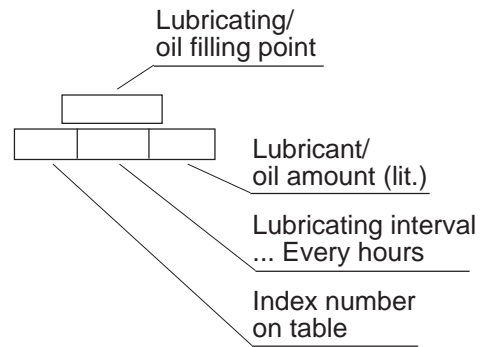

\*...See page 70.

The daily lubricating point is marked with  $\odot$  and the additional lubricating point is marked with  $\triangle$ .

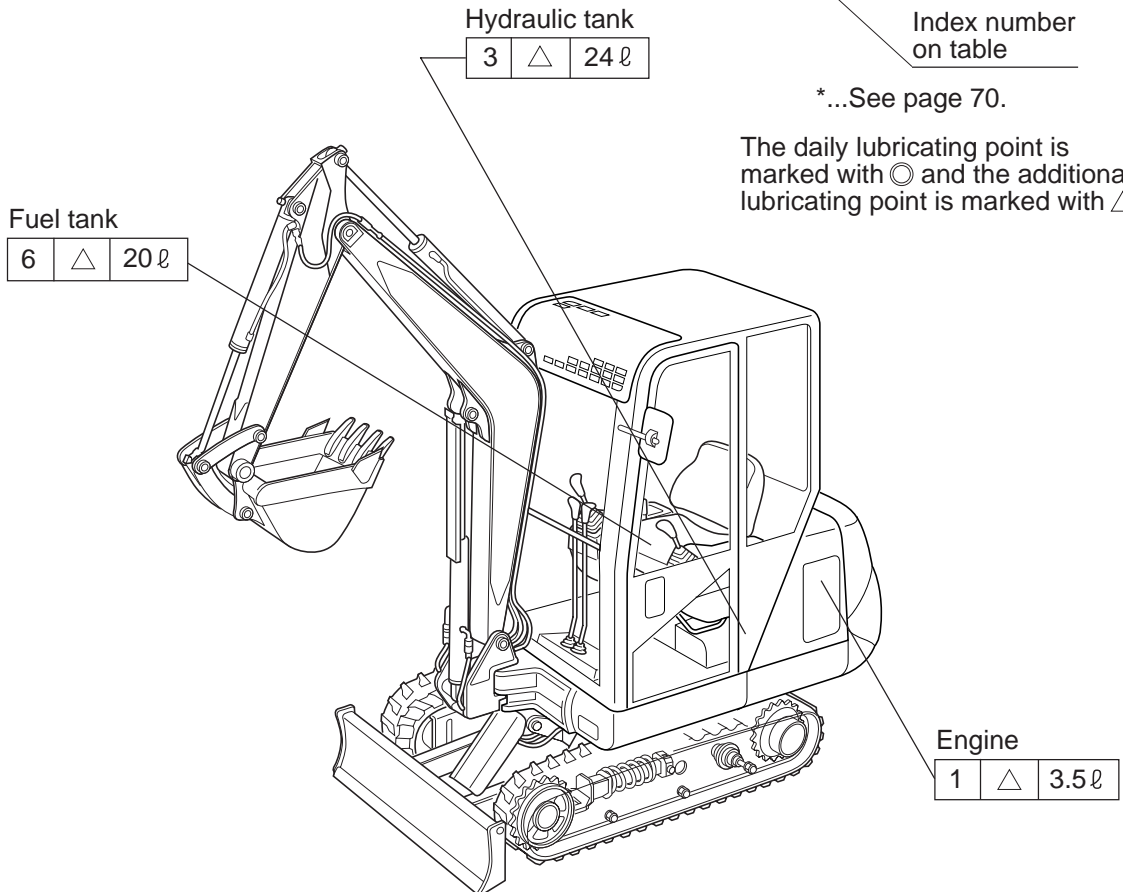

Swing cylinder head pin

4	$\odot$
---	---------

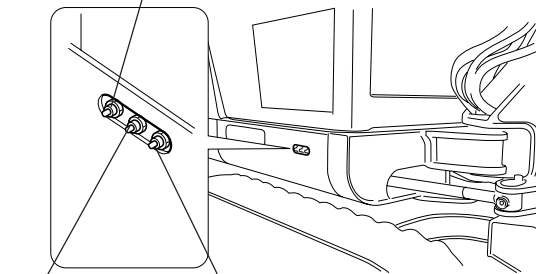

Slew gear

4	$\odot$
---	---------

Slew bearing

4	50
---	----

# LUBRICANTS

## Grease Supply Points - Undercarriage

How to read table

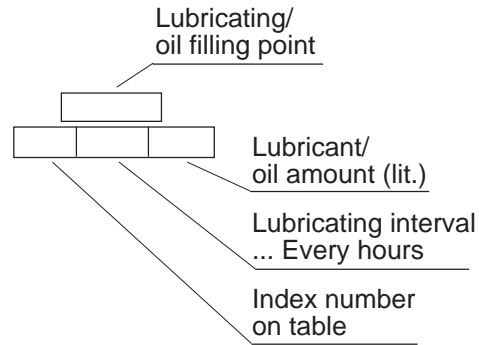

\*...See page 70.

The daily lubricating point is marked with  $\odot$  and the additional lubricating point is marked with  $\triangle$ .

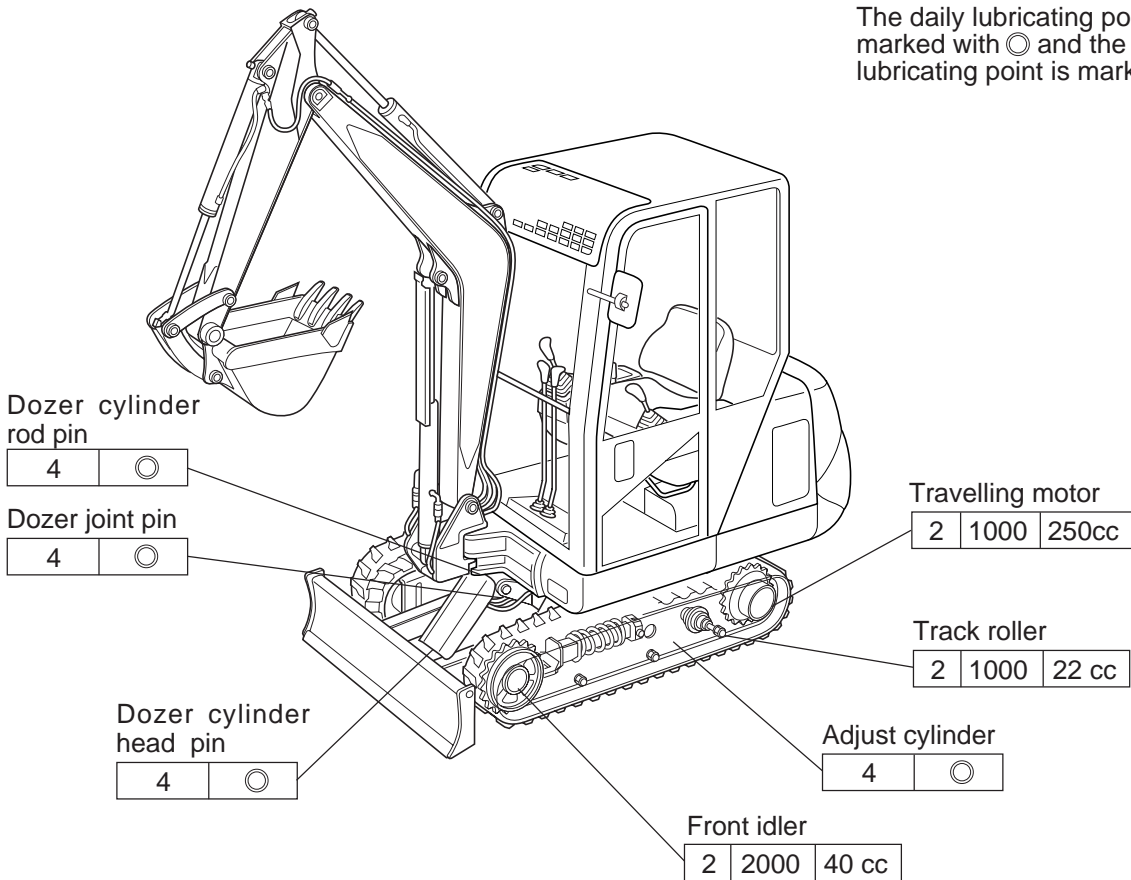

# LUBRICANTS

## Grease Supply Points - Attachments

How to read table

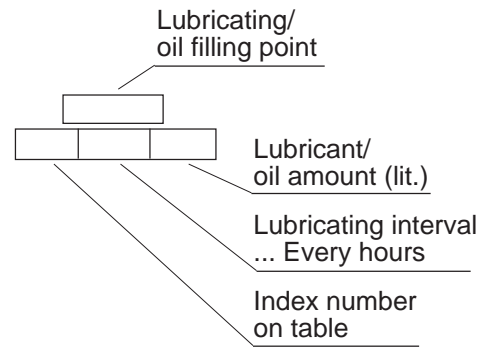

\*...See page 70.

The daily lubricating point is marked with  $\odot$  and the additional lubricating point is marked with  $\triangle$ .

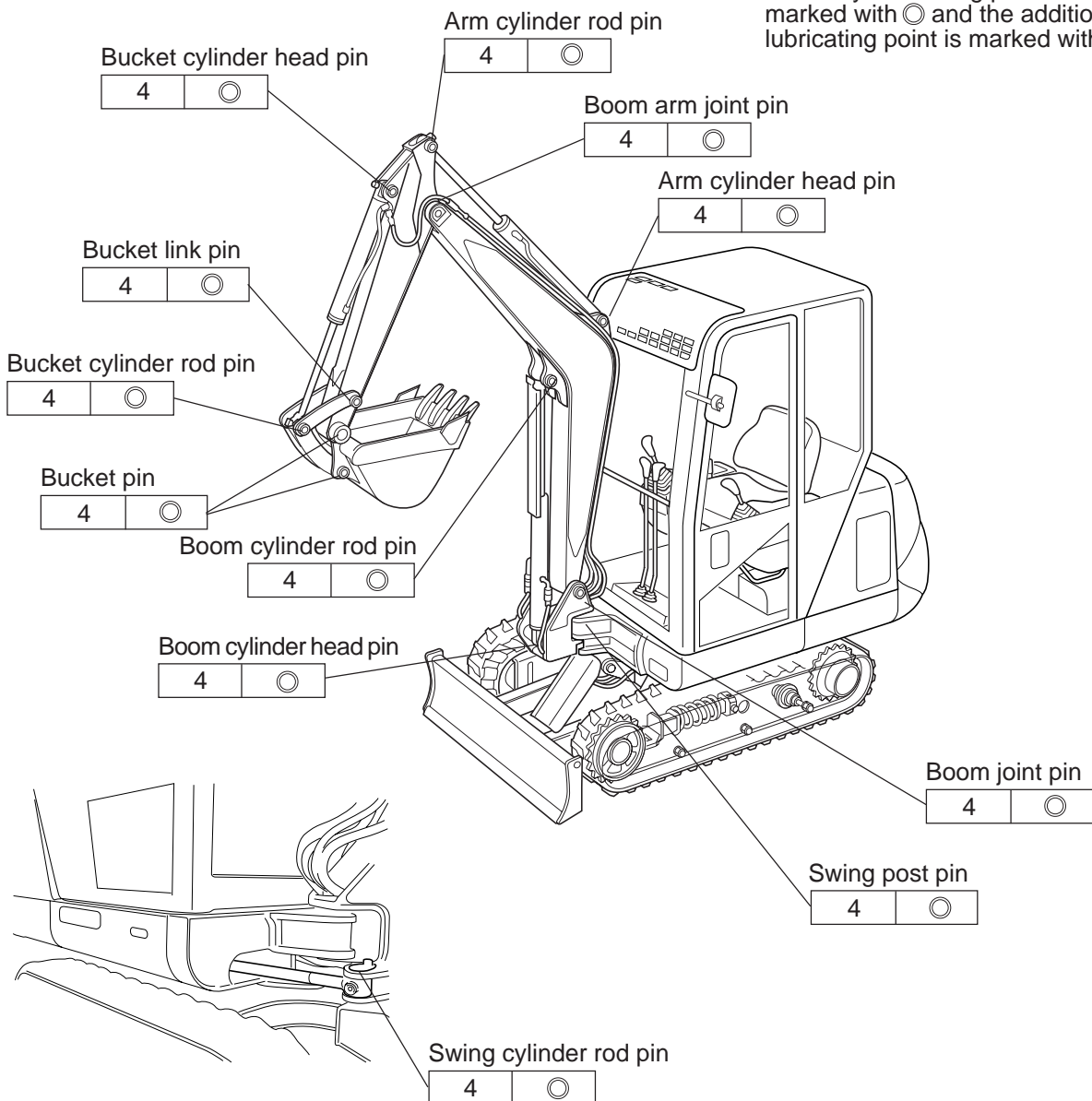



**OTHERS**

# DIMENSIONS AND SPECIFICATIONS

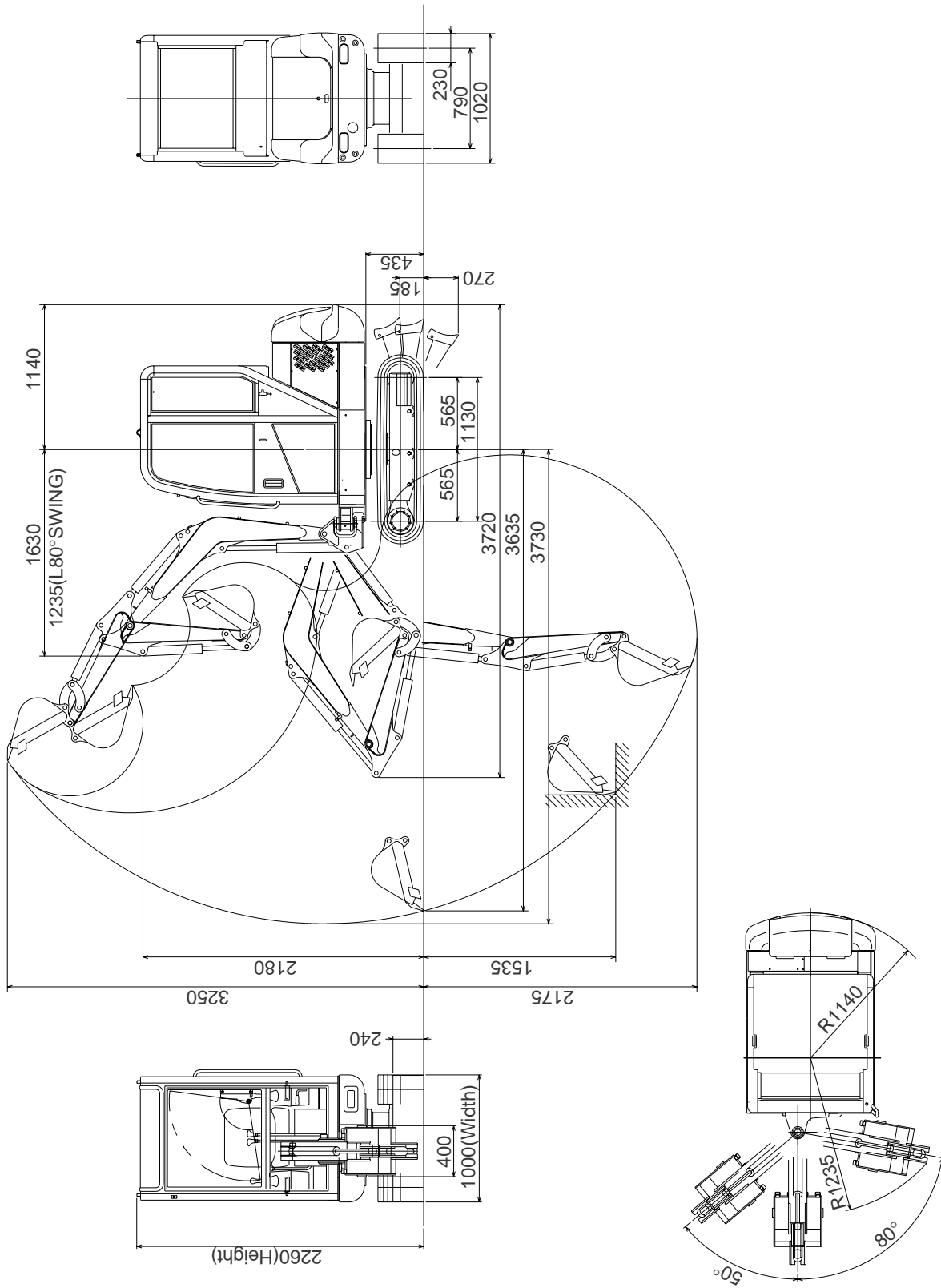

# DIMENSIONS AND SPECIFICATIONS

Description		Unit	Robex15-7	
Machine weight	Canopy	Rubber shoe	1460	
		Steel shoe	1510	
	Cabin	Rubber shoe	1570	
		Steel shoe	1620	
Standard bucket	Capacity	m <sup>3</sup>	0.04	
	Width	mm	400	
Engine	Maker, model		MITSUBISHI L3E	
	Rated power	kW(ps)/min <sup>-1</sup>	12.5(17)/2400	
	Displacement	cc	952	
Working range	Max.digging depth	mm	2175	
	Max.vertical digging depth		1535	
	Max.digging height		3250	
	Max.dumping height		2180	
	Max.digging reach		3730	
	Min.swing radius		Front	1630
			Swing	1235
	Rear end radius		1140	
Boom swing angle	deg	Left80/Right50		
Dimension	Overall length	mm	3720	
	Overall width		1000	
	Overall height		2260	
	Dozer(width × height)		1000×230	
Performance	Travel speed	km/hr	2.1/3.9	
	Swing speed	min <sup>-1</sup>	11.5	
	Gradeability	deg(%)	25(47)	
	Max.digging force	Bucket	kN(kgf)	14.4(1470)
		Arm	9.0(920)	
Max. drawbar pull		12.6(1290)		
Under-carriage	Ground pressure	Canopy&rubber shoe	kpa(kgf/cm <sup>2</sup> )	26(0.27)
		Cabin&rubber shoe	28(0.29)	
	Tumbler distance × track gauge	mm	1130×770	
	Track shoe width		230	
	Type of travelling motor		Piston shoe-in type	
Hydraulic	Crawler tension system		Grease cylinder	
	Type of hydraulic pump		Gear×3	
	Pump oil flow	ℓ /min	3×15.7	
	Auxiliary circuit oil flow		31.4	
	Relief valve setting pressure	MPa(kgf/cm <sup>2</sup> )	18.6(190)	
Capacity	Hydraulic oil tank	ℓ	24	
	Engine oil		3.5	
	Fuel tank		20	
	Cooling water		5.6	
Noise	Noise level(LwA/LpA)	dB	95/84	

# HYDRAULIC CIRCUIT

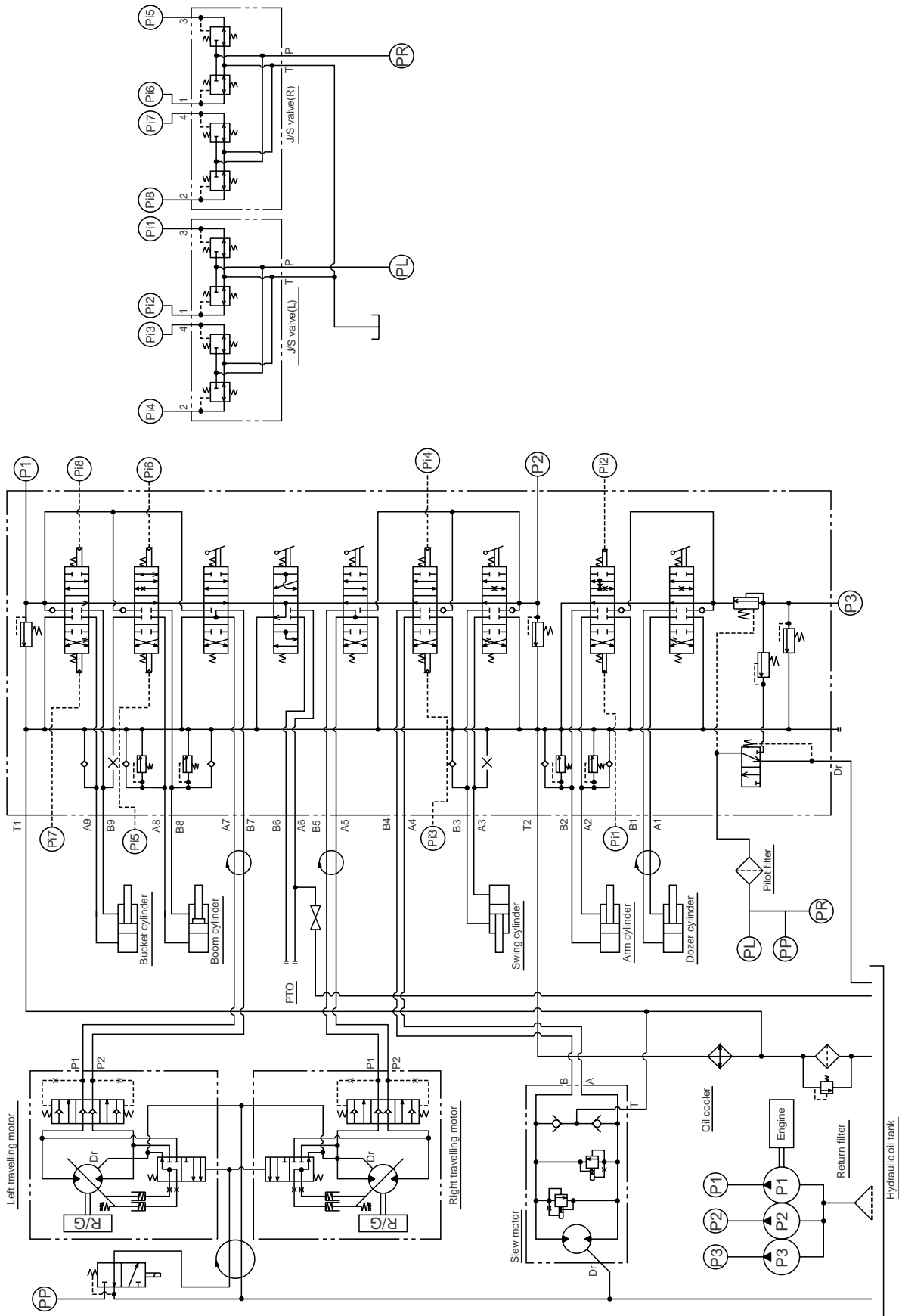

# ELECTRIC CIRCUIT

