

SPECIFICATIONS

1. MAJOR COMPONENTS

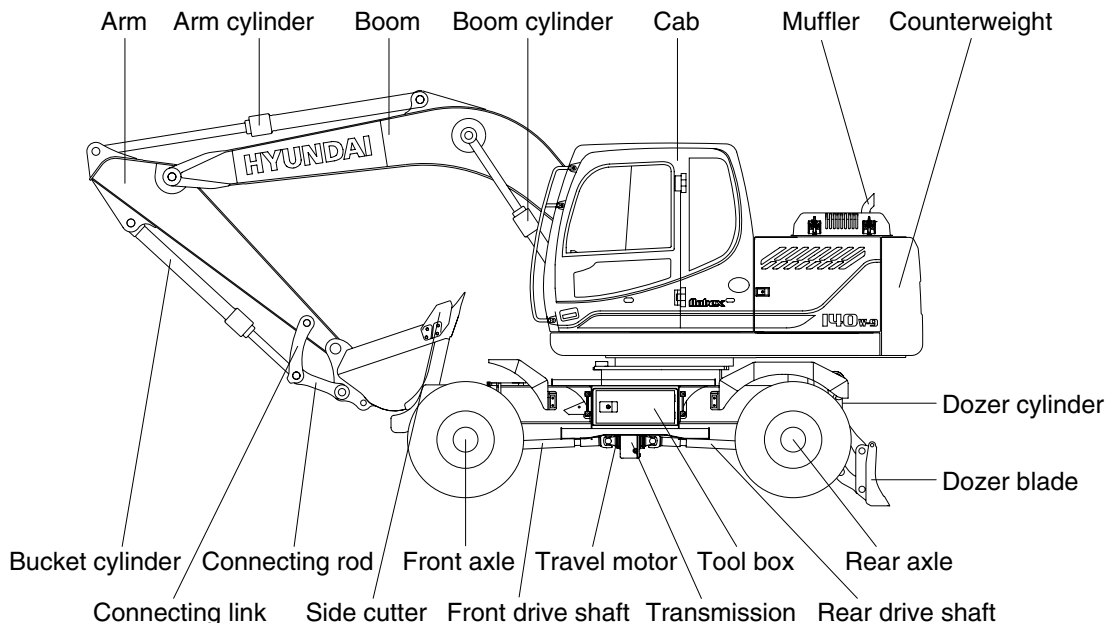
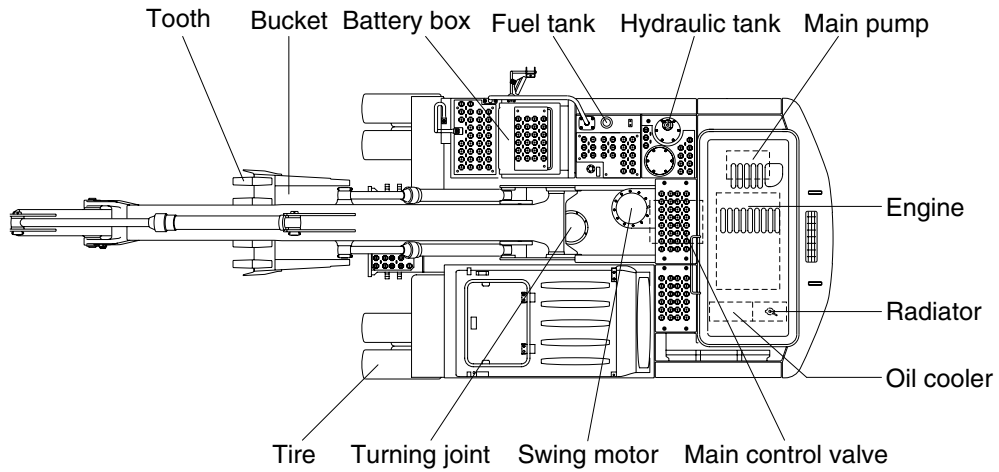

14W92SP01