

## 8. AIR CONDITIONER AND HEATER

### 1) CLEAN AND REPLACE OF OUTER FILTER

※ **Always stop the engine before servicing.**

- (1) Move seat and console box to arrow direction using the adjust lever.

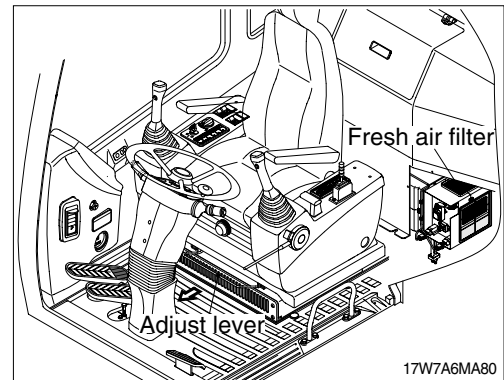

- (1) Remove the outer filter.

※ **When installing a filter, be careful not to change the filter direction.**

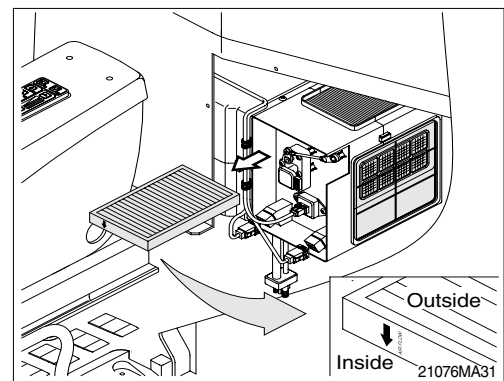

- (3) Clean the filter using a pressurized air (Below 2 kgf/cm<sup>2</sup>, 28 psi).

△ **When using pressurized air, be sure to wear safety glasses.**

- (4) Inspect the filter after cleaning. If it is damaged or badly contaminated, use a new filter.

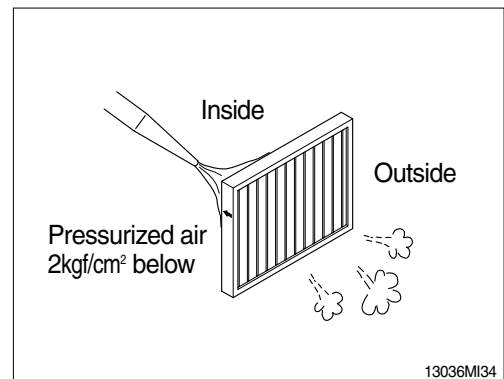

### 2) CLEAN AND REPLACE OF INNER FILTER

※ **Always stop the engine before servicing.**

- (1) Move seat and console box to arrow direction using the adjust lever.

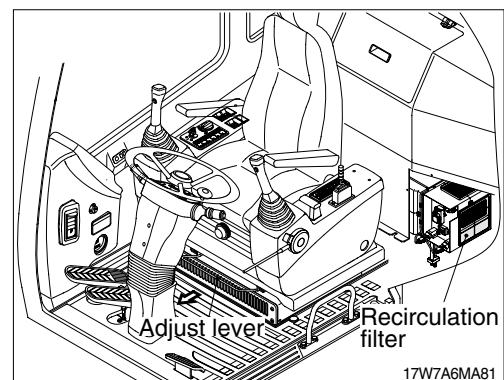

(2) Remove recirculation filter.

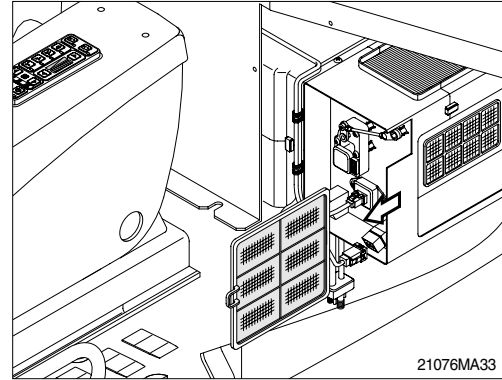

(3) Clean the recirculation filter using a pressurized air (Below 2 kgf/cm<sup>2</sup>, 28 psi) or washing with water.

△ **When using pressurized air, be sure to wear safety glasses.**

※ **Dry off after washing with water.**

(4) Inspect the filter after cleaning. If it is damaged or badly contaminated, use a new filter.

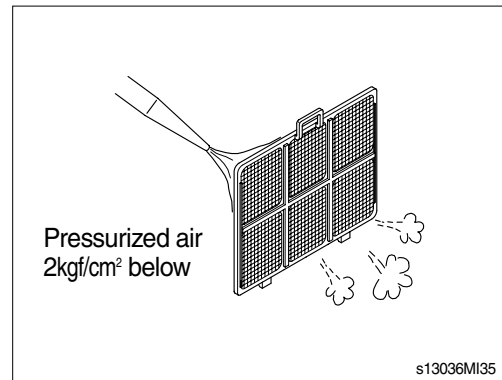

### 3) PRECAUTIONS FOR USING AIR CONDITIONER

- (1) When using the air conditioner for a long time, open the window once every one hour.
- (2) Be careful not to overcool the cab.
- (3) The cab is properly cooled if the operator feels cool when entering there from outside (About 5°C lower than the outside temperature).
- (4) When cooling, change air occasionally.

### 4) CHECK DURING SEASON

Ask the service center for replenishment of refrigerant or other maintenance service so that the cooling performance is not damaged.

### 5) CHECK DURING OFF-SEASON

Operate the air conditioner 2 or 3 times a month (Each for a few minutes) to avoid loss of oil film in the compressor.