

## 5. MAINTENANCE CHART

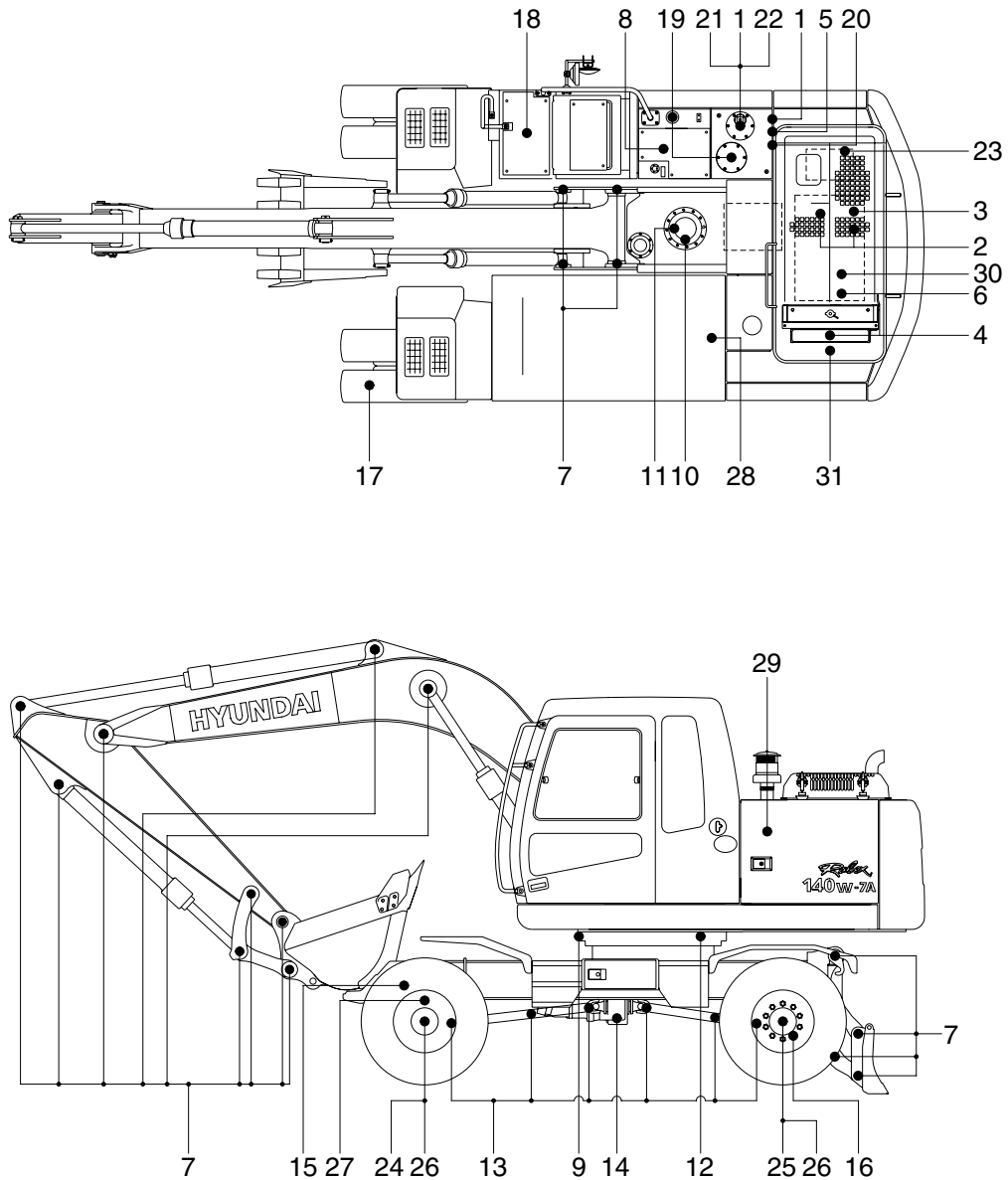

14W7A6MA05

### Caution

1. Service intervals are based on the hour meter reading.
2. The number of each item shows the lubrication point on the machine.
3. Stop engine while filling oil, and use no open flames.
4. For other details, refer to the service manual.

Service interval	No.	Description	Service action	Oil symbol	Capacity / (U.S.gal)	Service points No.
10Hours or daily	1	Hydraulic oil level	Check, Add	HO	124 (32.8)	1
	2	Engine oil level	Check, Add	EO	18.5 (4.9)	1
	4	Radiator coolant level	Check, Add	C	22 (5.8)	1
	5	Prefilter(water, element)	Check, Clean	-	-	1
	6	Fan belt tension & damage	Check, Clean	-	-	1
50 Hours or weekly	7	Attachment pins	Check, Add	PGL	-	17
	8	Fuel tank(water, sediment)	Check, Clean	-	-	1
	9	Swing bearing grease	Check, Add	PGL	-	3
	10	Swing reduction gear case	Check, Add	GO	2.5 (0.7)	1
	13	Drive shaft grease(flange bearing)	Check, Add	PGL	-	6
	14	Transmission case	Check, Add	EO	3.0 (0.8)	1
	15	Front axle pivot pin bushing	Check, Add	PGL	-	2
	16	Wheel nuts	Check, Tighten	-	-	40
250 Hours	17	Tire(air pressure)	Check, Add	-	-	8
	18	Battery(voltage)	Check	-	-	1
	21	Air breather element	Replace	-	-	1
	24	Front axle differential gear case	Check, Add	GO	7.8 (2.1)	1
	25	Rear axle differential gear case	Check, Add	GO	8.4 (2.2)	1
	26	Axle planetary gear case(front, rear)	Check, Add	GO	1.2 (0.32)	4
	27	Front axle steering case	Check, Add	PGL	-	4
500 Hours	28	Aircon & heater fresh filter	Check, Clean	-	-	1
	2	Engine oil	Change	EO	18.5 (4.9)	1
	3	Engine oil filter	Replace	-	-	1
	5	Prefilter(water, element)	Replace	-	-	1
	29	Air cleaner element(primary)	Check, Clean	-	-	1
	30	Fuel filter element	Replace	-	-	1
1000 Hours	31	Radiator, oil cooler, charge air cooler	Check, Clean	-	-	3
	10	Swing reduction gear case	Change	GO	2.5 (0.7)	1
	12	Swing gear and pinion grease	Change	PGL	4.0kg (8.7lb)	1
	14	Transmission case	Change	EO	3.0 (0.8)	1
	19	Hydraulic oil return filter	Replace	-	-	1
	20	Drain filter cartridge	Replace	-	-	1
1500 Hours	23	Pilot line filter element	Replace	-	-	1
	24	Front axle differential gear case	Change	GO	7.8 (2.1)	1
	25	Rear axle differential gear case	Change	GO	8.4 (2.2)	1
2000 Hours	26	Axle planetary gear case(front, rear)	Change	GO	1.2 (0.32)	4
	1	Hydraulic oil	Change	HO	124 (32.8)	1
	4	Radiator coolant	Change	C	22 (5.8)	1
As required	22	Hydraulic oil suction strainer	Check, Clean	-	-	1
	28	Aircon & heater fresh filter	Replace	-	-	1
	28	Aircon & heater recirculation filter	Clean, Replace	-	-	1
	29	Air cleaner element(safety)	Replace	-	-	1
	29	Air cleaner element(primary)	Replace	-	-	1

★ Severely dusty area operation only.

※ Oil symbol

Please refer to the recommended lubricants for specification.

DF : Diesel fuel

GO : Gear oil

HO : Hydraulic oil

C : Coolant

PGL : Grease

EO : Engine oil