

### 3. STARTING AND STOP THE ENGINE

#### 1) CHECK INDICATOR LIGHTS

- (1) Check if all the operating levers are on the neutral position.
- (2) Turn the starting switch to the ON position, and check following.
  - ① If all the lamps light ON and buzzer sounding for 2 seconds.
  - ② After lamp check 「1.00」, the version of cluster program, is displayed on 「LCD(3)」 for 5 seconds and the cluster returns to default.
  - ③ Only below lamps will light ON and all the other lights will turn OFF after 2 seconds.
    - Engine oil pressure warning lamp(1)
    - Battery charging warning lamp(2)

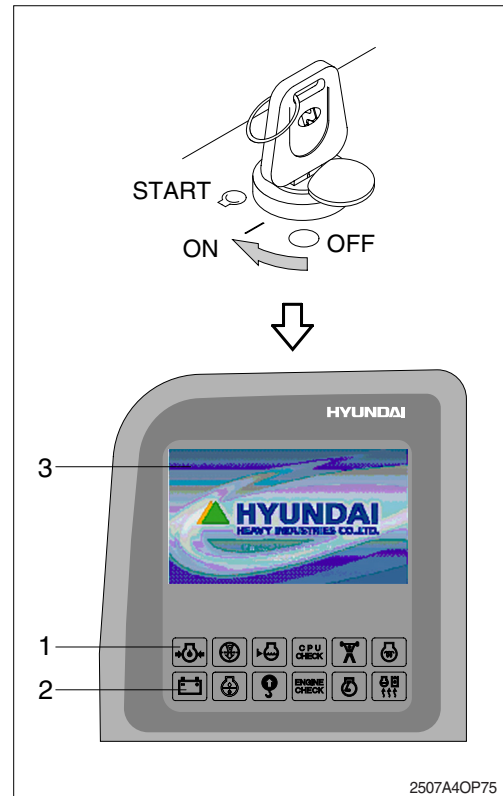

#### 2) STARTING ENGINE IN NORMAL TEMPERATURE

- ※ Sound the horn to warn the surroundings after checking if personnel or obstacles are in the area.
- (1) Turn the starting switch to START position to start the engine.
    - ※ If the engine does not start, allow the starter to cool for about 2 minutes before attempting to start the engine again.
  - (2) Release the starting switch instantly after the engine starts to avoid possible damage to the starting motor.

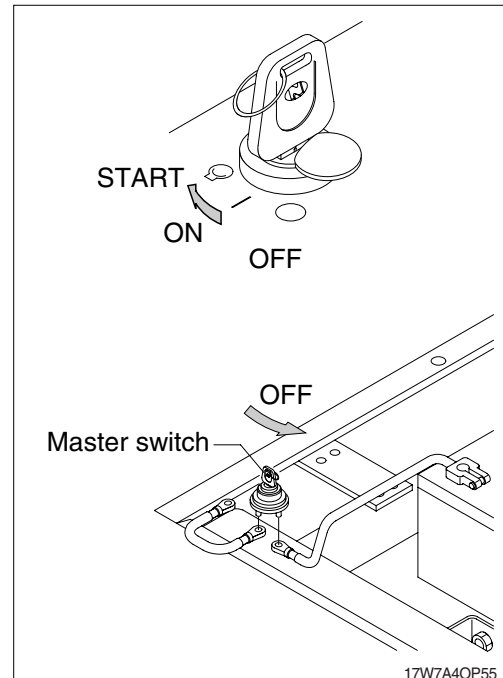

### 3) STARTING ENGINE IN COLD WEATHER

- ※ Sound horn to warn surroundings after checking if there are obstacles in the area.
- ※ Replace the engine oil and fuel referring to recommended oils at page 2-16.
- ※ Fill the anti-freeze solution to the coolant as required.
- ※ If you turn ON the starting switch, the fuel warmer is automatically operated to heat the fuel by sensing the coolant temperature.

- (1) Check if all the levers are in the neutral position.
  - (2) Turn the starting switch to ON position, and wait 1~2 minutes. More time may take according to ambient temperature.
  - (3) Press the preheat switch ON.
  - (4) Start the engine by turning the starting switch to the START position after the preheat pilot lamp OFF.
- ※ If the engine does not start, allow the starter to cool for about 2 minutes before attempting to start the engine again.
- (5) Release the starting switch immediately after starting engine.
  - (6) The operation for the warming up machine is automatic.

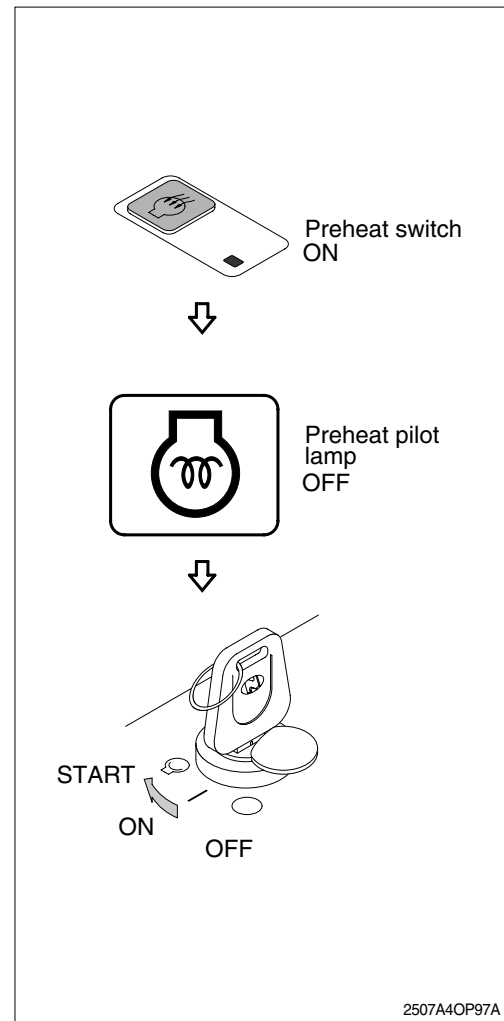

### 4) INSPECTION AFTER ENGINE START

Inspect and confirm the following after engine starts.

- (1) Is the level gauge of hydraulic oil tank in the normal level?
  - (2) Are there leakages of oil or water?
  - (3) Are all the warning lamps OFF(1~8)?
  - (4) Is the indicator of water temperature gauge(9) and hydraulic temperature gauge(10) in the 2nd ~10th step zone?
  - (5) Is the engine sound and the color of exhaust gas normal?
  - (6) Are the sound and vibration normal?
- ※ Do not increase engine speed quickly after starting, it can damage engine or turbocharger.
  - ※ If there are problems in the control panel, stop the engine immediately and correct problem as required.

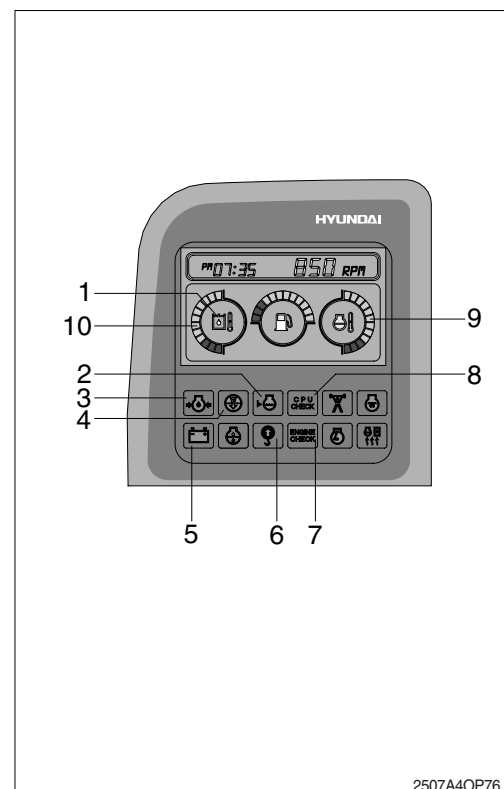

## 5) WARMING-UP OPERATION

- ※ The most suitable temperature for the hydraulic oil is about 50°C (122°F).

It can cause serious trouble in the hydraulic system by sudden operation when the hydraulic oil temperature is below 25°C (77°F).

Then temperature must be raised to at least 25°C (77°F) before starting work.

- (1) Run the engine at low idling for 5 minutes.
- (2) Speed up the idling and run the engine at mid-range speed.
- (3) Operate bucket lever for 5 minutes.
  - ※ Do not operate anything except bucket lever.
- (4) Run the engine at the high speed and operate the bucket lever and arm lever for 5-10 minutes.
  - ※ Operate only the bucket lever and arm lever.
- (5) This warming-up operation will be completed by operation of all cylinders several times, and operation of swing and traveling.
  - ※ Increase the warming-up operation during winter.

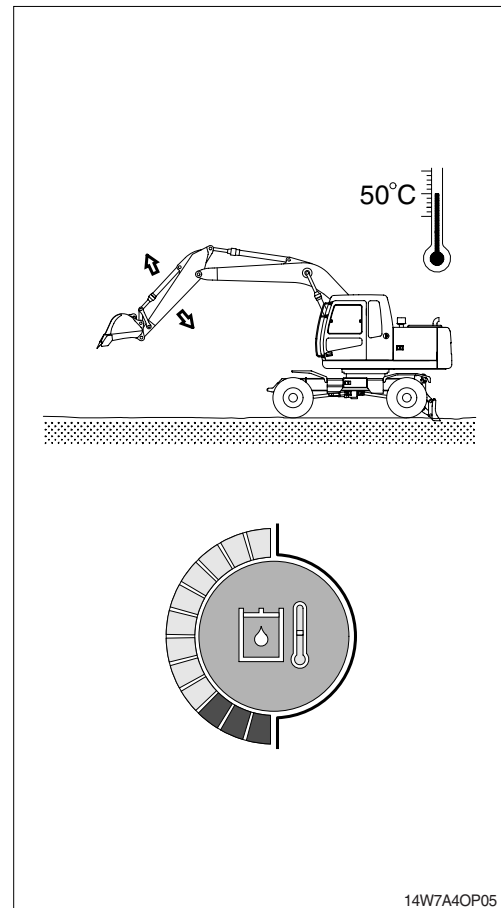

## 6) TO STOP THE ENGINE

- ※ If the engine is abruptly stopped before it has cooled down, engine life may be greatly shortened. Consequently, do not abruptly stop the engine apart from an emergency.
- ※ In particular if the engine has overheated, do not abruptly stop it but run it at medium speed to allow it to cool gradually, then stop it.

- (1) Place the forward/backward lever in the neutral.
- (2) Down the bucket, outrigger and dozer blade on the ground then put all the levers in the neutral position.
- (3) Put the parking switch in the parking position.
- (4) Run the engine at low idling speed for about 5 minutes.
- (5) Return the key of starting switch to the OFF position.
- (6) Remove the key to prevent other people using the machine and LOCK safety lever.
- (7) Lock the cab door.

