

## 12. RCV LEVER OPERATING PATTERN(STD)

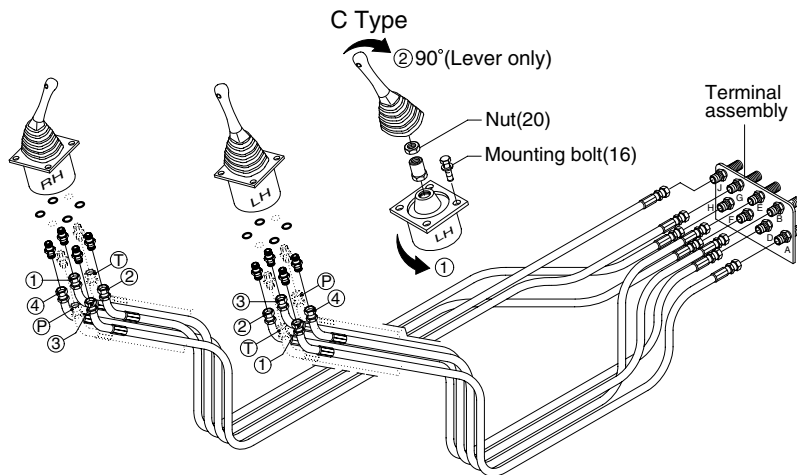

※ Whenever a change is made to the machine control pattern also exchange the pattern label in the cab to match the new pattern.

2107A4OP95

Pattern	Operation		Control function	Hose connection(Port)									
	Left	Right		RCV lever	Change of MCV port								
					From	To							
ISO Type			Left	① Arm out	②	D	-						
				② Arm in	④	E	-						
				③ Swing right	③	B	-						
				④ Swing left	①	A	-						
			Right	⑤ Boom lower	④	J	-						
				⑥ Boom raise	②	H	-						
				⑦ Bucket out	①	F	-						
				⑧ Bucket in	③	G	-						
Hyundai			Left	① Boom lower	See next page								
				② Boom raise									
A Type			Left	③ Swing right									
				④ Swing left									
				Right				⑤ Arm out					
								⑥ Arm in					
			B Type						Left	① Boom lower	②	D	J
										② Boom raise	④	E	H
③ Bucket in	③	A	G										
④ Bucket out	①	B	F										
C Type			Right	⑤ Arm out	④	J	D						
				⑥ Arm in	②	H	E						
				⑦ Swing right	①	F	A						
				⑧ Swing left	③	G	B						
C Type			Left	① Loosen the RCV lever mounting bolt(16) and rotates lever assy 90° counterclockwise; then install. ② To put lever in correct position, disassemble nut(20) and rotates only lever 90° clockwise.									
			Right	Same as ISO type									

# RCV LEVER OPERATING PATTERN(option, A type)

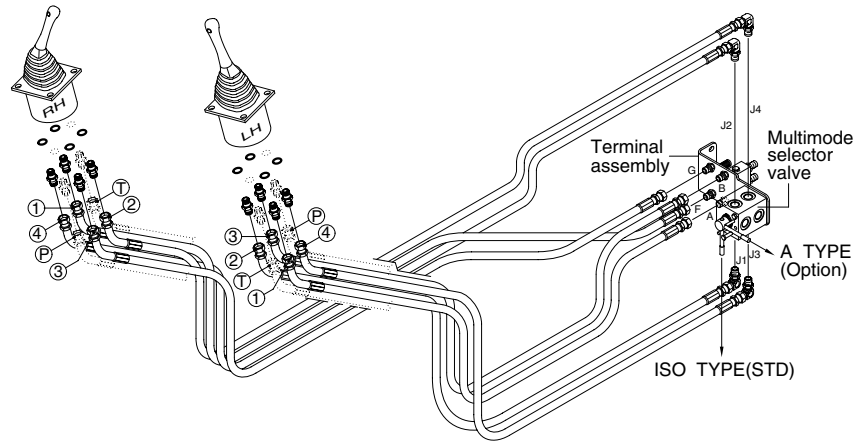

1607A40P94A

Pattern	Operation		Control function	Hose connection(Port)			
	Left	Right		RCV lever	MCV port		
A Type			Left	1 Boom lower	2	J1	
				2 Boom raise	4	J3	
				3 Swing right	3	B	
				4 Swing left	1	A	
	Right			Right	5 Arm out	4	J2
					6 Arm in	2	J4
					7 Bucket out	1	F
					8 Bucket in	3	G

1) The machine control pattern can easily be changed from the "ISO" type to the "A" type by changing the position of the lever.

**▲ Before starting the machine, check the lever position of multimode selector valve and actual operating of attachment.**

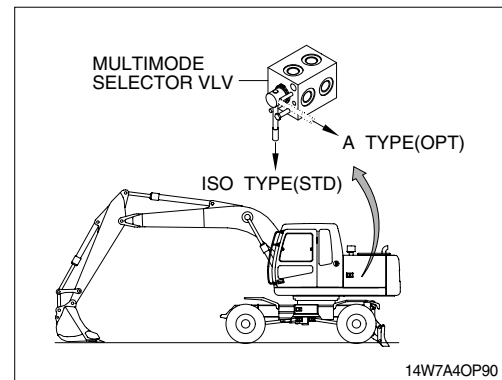

14W7A40P90

## 2) Change of operating pattern(ISO → A type)

- (1) Loosen bolt(11).
- (2) Move lever from the "ISO" type to "A" type position.
- (3) After setting the lever, tighten bolt to secure lever.

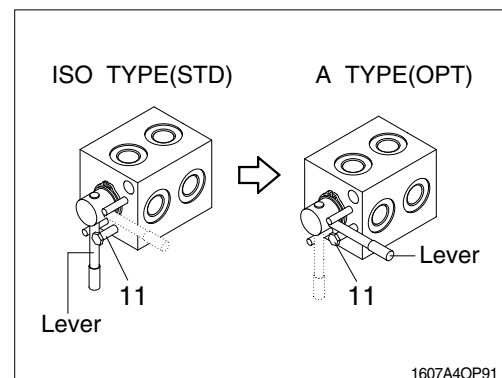

1607A40P91