

HYDRAULIC BREAKER AND QUICK CLAMP

1. SELECTING HYDRAULIC BREAKER

- 1) Become familiar with the manual and select breakers suitable to machine specifications.
- 2) Make careful selection in consideration of oil quantity, pressure and striking force, to enable satisfied performance.
- 3) When apply a breaker to the machine, consult your local dealer of Hyundai for further explanation.

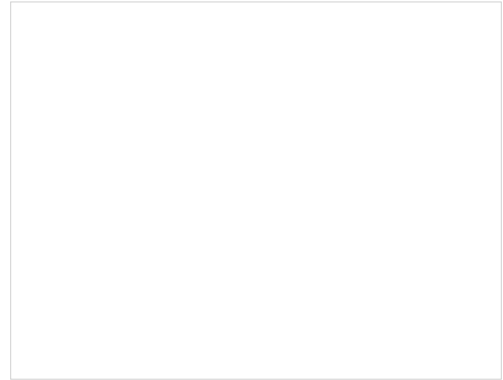

2. CIRCUIT CONFIGURATION

- 1) As for breaker oil pressure line, use extra spool of main control valve.
- 2) Set proper breaker pressure on load relief valve.
- 3) The pressure of the ROBEXR140W-7 system is 330kgf/cm²(4700psi).

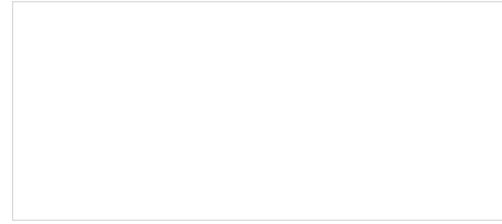

4) Adjusting oil quantity

- (1) Use the breaker mode from work mode. Default oil flow quantity is 110.7lpm at 2100rpm. Use accel dial switch to control the oil flow quantity.
 - (2) If the quantity of hydraulic oil is not controlled properly, it causes short lifecycle of the breaker and the machine by increased breaking force and count.
- 5) The accumulator should be used to the breaker charging and return line. Keep the pressure pulsation of pump below 60kgf/cm²(853psi) by installing the accumulator. If the accumulator is not used, it will be damage as the input wave is delivered.
 - 6) Do not connect the breaker return line to the main control, but connect to the return line front of the cooler.
 - 7) Do not connect the breaker return line to drain lines, such as of swing motor, travel motor or pump, otherwise they should be damaged.
 - 8) One of spool of the main control valve should be connected to the tank.
 - 9) Select the size of pipe laying considering the back pressure.
 - 10) Shimless tube should be used for the piping. The hose and seal should be used Hyundai genuine parts.
 - 11) Weld the bracket for pipe clamp to prevent damage caused by vibration.

Oil quantity according to engine rpm

Engine rpm	Oil flow /min	Oil flow U.S.gpm
2000	105.4	27.9
1900	100	26.4
1800	95	25.1
1700	90	23.78

Relief pressure : 200kgf/cm²

3. MAINTENANCE

1) MAINTENANCE OF HYDRAULIC OIL AND FILTER

- (1) As machine with an hydraulic breaker provides the hydraulic oil becomes severely contaminated.
- (2) So, unless frequently maintained, the machine may easily go out of order.
- (3) Inspect and maintain hydraulic oil and 4 kinds of filter elements in particular, in order to prolong machine life.
- (4) Replace when the breaker work is used for short time according to the standard of right graph.

2) RELEASE THE PRESSURE IN BREAKER CIRCUIT

When breaker operating is finished, stop engine and push pedal or switch for breaker to release pressure in breaker circuit.

If pressure still remains, the lifetime of the diaphragm in the accumulator will be shortened.

- 3) Be careful to prevent contamination by dust, sand and etc.
If such pollution become mixed into the oil, the pump moving parts will wear abnormally, shorten lifetime and become damaged.
- 4) When operating breaker, bolts and nuts of main equipment may be loosened by vibration. So, it must be inspected periodically.

Service interval

unit : hours

Attachment	Operating rate	Hydraulic oil	Filter element
Bucket	100%	2,000	250
Breaker	100%	600	100

Replace following filter same time

- Hydraulic return filter : 1EA
- Pilot line filter : 1EA
- Element in hydraulic tank breather : 1EA
- Drain filter cartridge : 1EA

Filter replace guide for hydraulic breaker

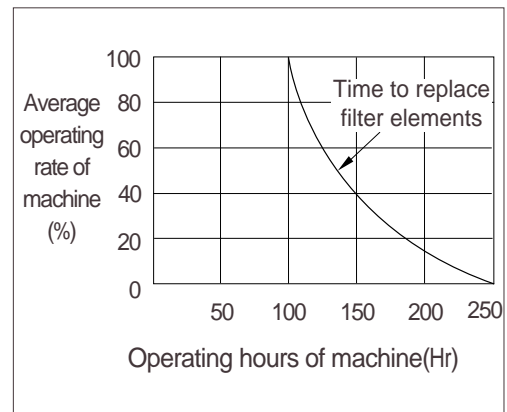

Oil change guide for hydraulic breaker

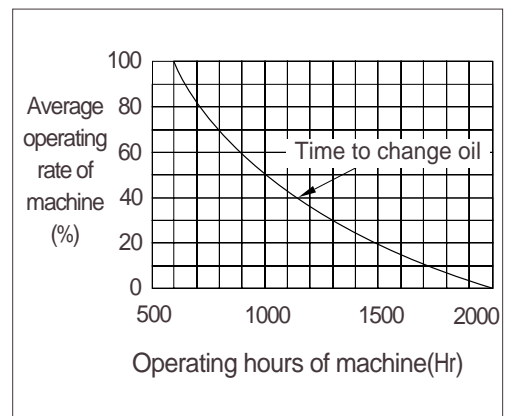

4. PRECAUTIONS WHILE OPERATING THE BREAKER

1) DO NOT BREAK ROCK WHILE LOWERING

As the breaker is heavy in comparison with bucket, it must be operated slowly.

If breaker is rapidly pushed down, working device may be damaged.

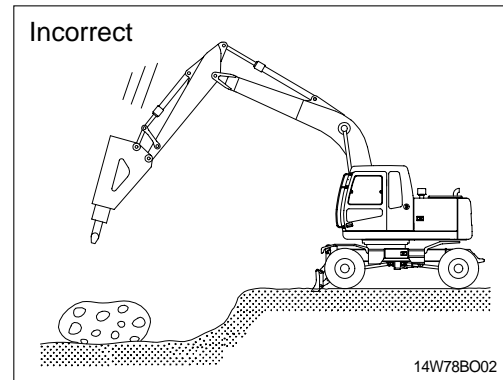

2) DO NOT USE BREAKER TO CARRY BROKEN STONE OR ROCK BY SWING OPERATING

This may damage the operation device and swing system.

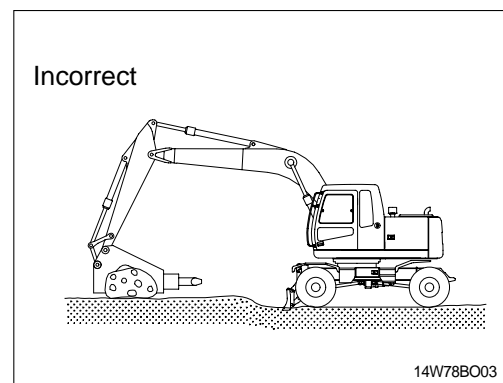

3) OPERATE BREAKER WITH A GAP IN EXCESS OF 100mm(4 inches) FROM THE END OF THE STROKE TIP

If breaker is operated with the end tip, the cylinder may be damaged.

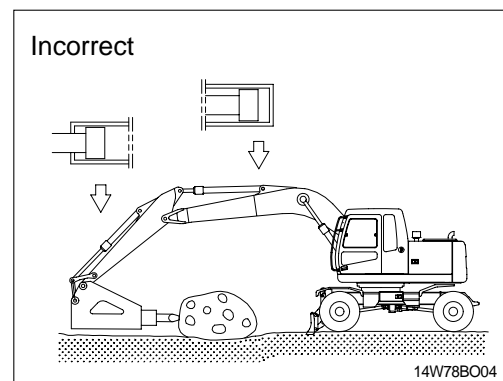

4) IF THE HYDRAULIC HOSES VIBRATE EXCESSIVELY

If the machine used in this condition continuously this will effect badly on the machine such as loosening bolt, oil leakage, damage of pump pipe and etc.

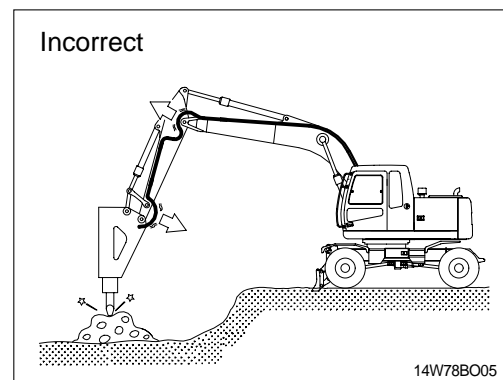

5) DO NOT CONTINUE TO WORKING OVER ONE MINUTE AT SAME POSITION OF BOOM AND ARM

This will increase the temperature of the oil, and cause problem in the accumulator and seals.

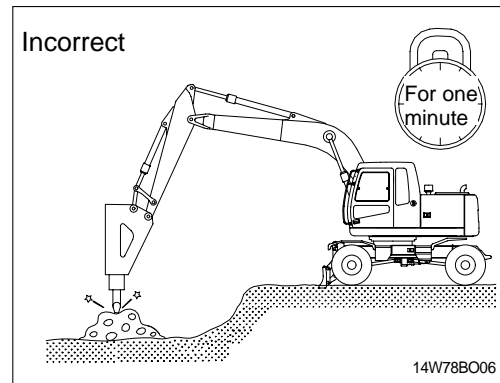

6) DO NOT MOVE MACHINE OR BREAKER WHILE STRIKING

Do not move hammer while striking.
This will cause damage to the working device and the swing system.

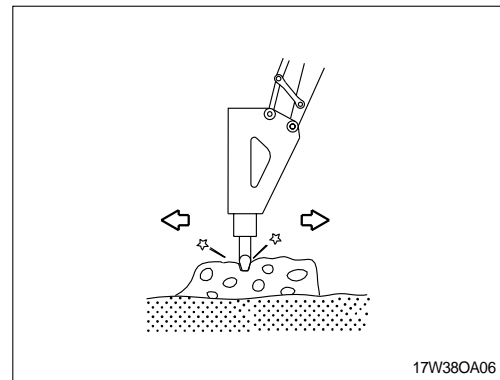

7) TAKE CARE OF CHISEL AND BOOM INTERFACE

Make sure of the arm and bucket control lever operation.

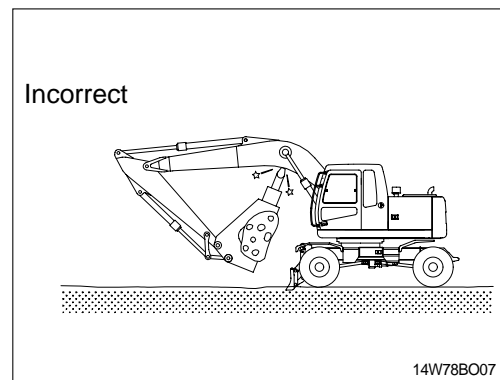

8) Do not extend the bucket cylinder fully and thrusting to raise the machine off the ground.

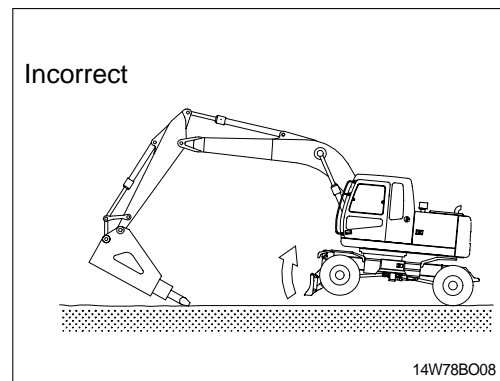

5. QUICK CLAMP

1) FIXING BUCKET WITH QUICK CLAMP

- (1) Before fixing bucket, remove safety pin of the moving hook.
- (2) Pulling safety button, press the quick clamp switch to unlock position. Then, the moving hook is placed on release position.

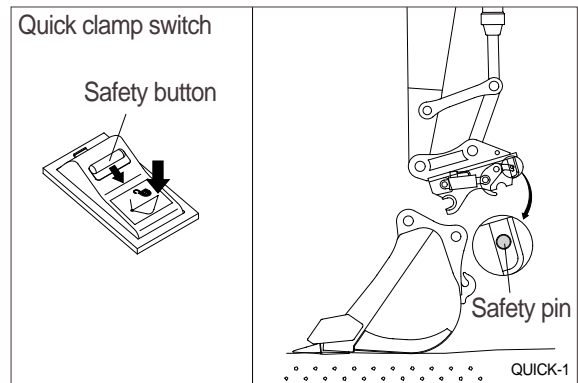

- (3) Aligning the arm and bucket, insert static hook of quick clamp to the bucket pin.

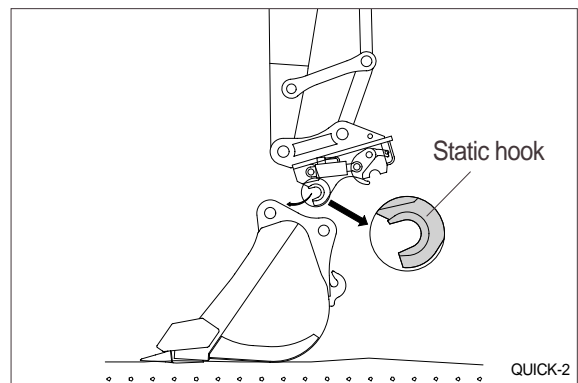

- (4) Operate RCV lever to bucket-in position. Then, the moving hook is coupled with the bucket link pin. Make sure that the moving hook is completely contacted with bucket link pin.

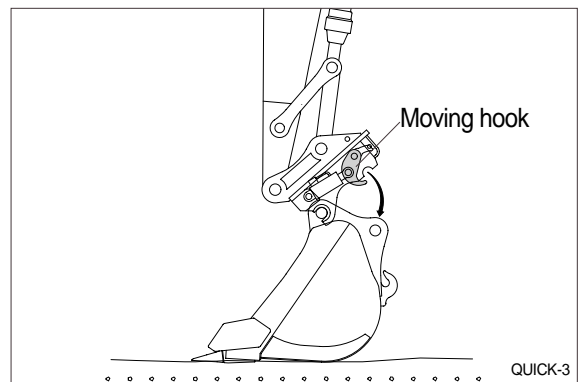

- (5) Press quick clamp switch to lock position. Operate RCV lever to bucket-in position. **Be sure to check connection status between bucket pins and hooks of quick clamp**

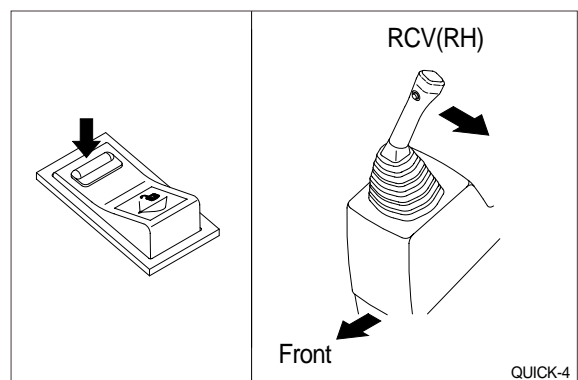

- (6) After checking the connection status between bucket pins and hooks of quick clamp, **insert safety pin of moving hook to lock position.**

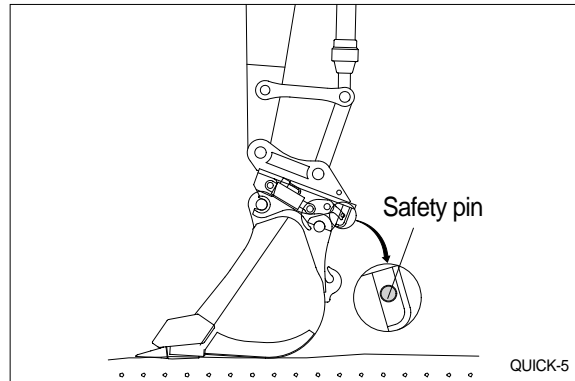

2) REMOVE BUCKET FROM QUICK CLAMP

Removing procedure is reverse of fixing.

3) PRE-CAUTION OF USING QUICK CLAMP.

- ⚠ When operating the machine with quick clamp, confirm that the quick clamp switch is lock position and safety pin of moving hook is inserted. Operating the machine with quick clamp switch unlocked and without safety pin of moving hook can cause the bucket to drop off and bring about the accident.

- ⚠ Serious injury or death can result from this accident.

- ⚠ Be careful to operate the machine equipped with quick clamp. The bucket may hit cab, boom and boom cylinders when it reaches vicinity of them.

HYUNDAI will not be responsible for any injury or damage in case that safety pin is not installed properly.

