

1. INSTRUCTION

1) INTERVAL OF MAINTENANCE

- (1) You may inspect and service the machine by the period as described at page 6-11 based on hour meter at control panel.
- (2) Shorten the interval of inspect and service depending on site condition.(Such as dusty area, quarry, sea shore and etc.)
- (3) Practice the entire related details at the same time when the service interval is doubled.
For example, in case of 100hours, carry out all the maintenance 「 Each 100hours, each 50 hours and daily service 」 at the same time.

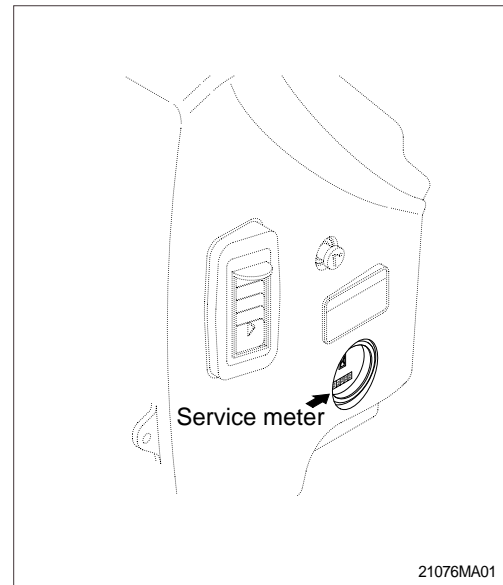

2) PRECAUTION

- (1) Start to maintenance after you have the full knowledge of machine.
- (2) The monitor installed on this machine does not entirely guarantee the condition of the machine.
Daily inspection should be performed according to clause 4, maintenance check list.
- (3) Engine and hydraulic components have been preset in the factory.
Do not allow unauthorized personnel to reset them.
- (4) Ask to your local dealer or Hyundai for the maintenance advice if unknown.
- (5) Drain the used oil and coolant in a container and handle according to the method of handling for industrial waste to meet with regulations of each province or country.

3) PROPER MAINTENANCE

(1) Replace and repair of parts

It is required to replace the wearable and consumable parts such as bucket tooth, side cutter, filter and etc., regularly.

Replace damaged or worn parts at proper time to keep the performance of machine.

- (2) Use genuine parts.
- (3) Use the recommended oil.
- (4) Remove the dust or water around the inlet of oil tank before supplying oil.
- (5) Drain oil when the temperature of oil is warm.
- (6) Do not repair anything while operating the engine.
Stop the engine when you fill the oil.
- (7) Relieve hydraulic system of the pressure before repairing the hydraulic system.
- (8) Confirm if the cluster is in the normal condition after completion of service.
- (9) For more detail information of maintenance, please contact local Hyundai dealer.

Be sure to start the maintenance after fully understand the chapter 1, safety hints.

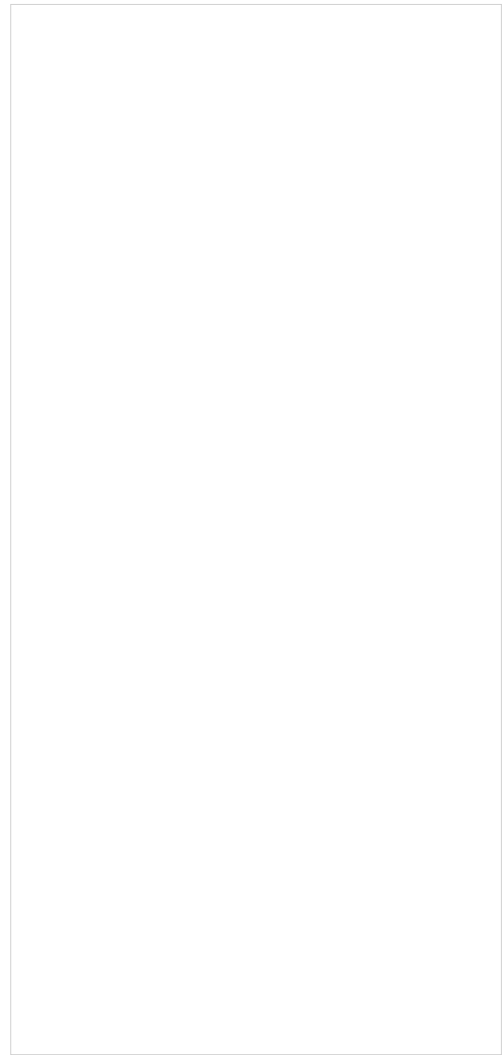

4) RELIEVING THE PRESSURE IN THE HYDRAULIC SYSTEM

Spouting of oil can cause the accident when loosening the cap or hose right after the operating of machine as the machine or oil is on the high pressure on the condition.

Be sure to relieve the pressure in the system before repairing hydraulic system.

- (1) Place machine in parking position, and stop the engine.

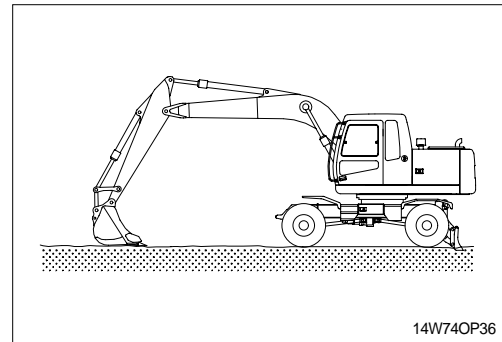

- (2) Set the safety lever completely in the release position, operate the control levers and pedals fully to the front, rear, left and right, to release the pressure in the hydraulic circuit.

This does not completely release the pressure, so when serving hydraulic component, loosen the connections slowly and do not stand in the direction where the oil spurt out.

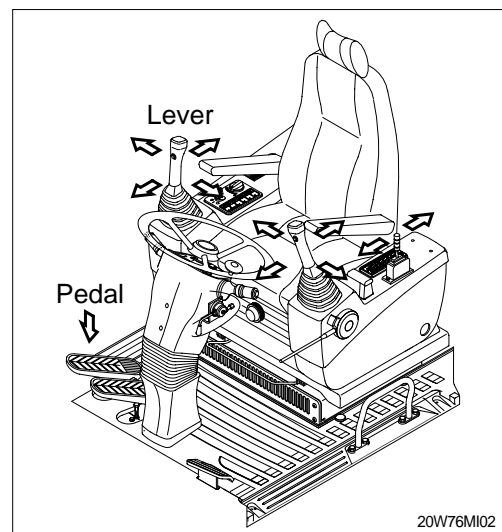

- (3) Loosen the cap and relieve the pressure in the tank by pushing the top of the air breather.

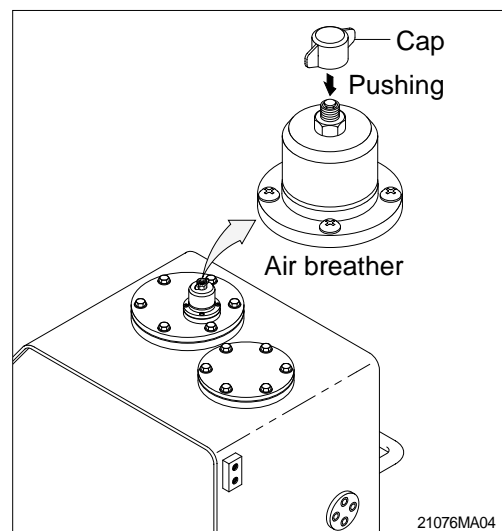

5) PRECAUTION WHEN INSTALLING HYDRAULIC HOSES OR PIPES

- (1) Be particularly careful that the joint of hose, pipe and functioning item are not damaged.
Avoid contamination.
- (2) Assemble after cleaning the hose, pipe and joint of functioning item.
- (3) Use genuine parts.
- (4) Do not assemble the hose in the condition of twisted or sharp radius.
- (5) Keep the specified tighten torque.

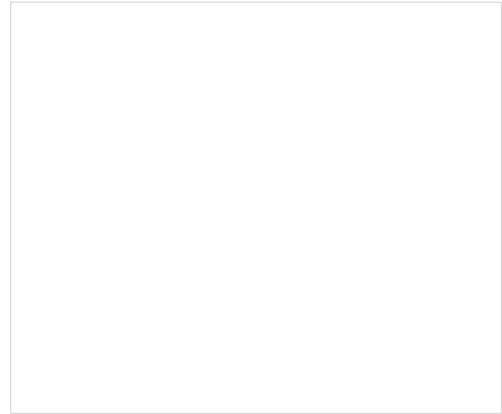

6) PERIODICAL REPLACEMENT OF SAFETY PARTS

(1) It is desirable to do periodic maintenance the machine for using the machine safely for a long time.

However, recommend to replace regularly the parts related safety not only safety but maintain satisfied performance.

(2) These parts can cause the disaster of life and material as the quality changes by passing time and it is worn, diluted, and gets fatigued by using repeatedly.

These are the parts which the operator can not judge the remained lifetime of them by visual inspection.

(3) Repair or replace if an abnormality of these parts is found even before the recommended replacement interval.

Periodical replacement of safety parts			Interval
Engine		Fuel hose(Tank-engine)	Every 2 years
		Heater hose (Heater-engine)	
Hydraulic system	Main circuit	Pump suction hose	Every 2 years
		Pump delivery hose	
		Swing hose	
	Working device	Boom cylinder line hose	Every 2 years
		Arm cylinder line hose	
		Bucket cylinder line hose	
	Brake line	Service brake line hose	Every 2 years
		Parking brake line hose	
		Steering line hose	

1. Replace O-ring and gasket at the same time when replacing the hose.

2. Replace clamp at the same time if the hose clamp is cracked when checking and replacing the hose.

2. TIGHTENING TORQUE

Use following table for unspecified torque.

1) BOLT AND NUT

(1) Coarse thread

Bolt size	8T		10T	
	kgf · m	lbf · ft	kgf · m	lbf · ft
M 6 × 1.0	0.9 ~ 1.3	6.5 ~ 9.4	1.1 ~ 1.7	8.0 ~ 12.3
M 8 × 1.25	2.0 ~ 3.0	14.5 ~ 21.7	2.7 ~ 4.1	19.5 ~ 29.7
M10 × 1.5	4.0 ~ 6.0	28.9 ~ 43.4	5.5 ~ 8.3	39.8 ~ 60.0
M12 × 1.75	7.4 ~ 11.2	53.5 ~ 81.0	9.8 ~ 15.8	70.9 ~ 114
M14 × 2.0	12.2 ~ 16.6	88.2 ~ 120	16.7 ~ 22.5	121 ~ 163
M16 × 2.0	18.6 ~ 25.2	135 ~ 182	25.2 ~ 34.2	182 ~ 247
M18 × 2.0	25.8 ~ 35.0	187 ~ 253	35.1 ~ 47.5	254 ~ 344
M20 × 2.5	36.2 ~ 49.0	262 ~ 354	49.2 ~ 66.6	356 ~ 482
M22 × 2.5	48.3 ~ 63.3	349 ~ 458	65.8 ~ 98.0	476 ~ 709
M24 × 3.0	62.5 ~ 84.5	452 ~ 611	85.0 ~ 115	615 ~ 832
M30 × 3.0	124 ~ 168	898 ~ 1214	169 ~ 229	1223 ~ 1656
M36 × 4.0	174 ~ 236	1261 ~ 1704	250 ~ 310	1808 ~ 2242

(2) Fine thread

Bolt size	8T		10T	
	kgf · m	lbf · ft	kgf · m	lbf · ft
M 8 × 1.0	2.2 ~ 3.4	15.9 ~ 24.6	3.0 ~ 4.4	21.7 ~ 31.8
M10 × 1.2	4.5 ~ 6.7	32.5 ~ 48.5	5.9 ~ 8.9	42.7 ~ 64.4
M12 × 1.25	7.8 ~ 11.6	56.4 ~ 83.9	10.6 ~ 16.0	76.7 ~ 116
M14 × 1.5	13.3 ~ 18.1	96.2 ~ 131	17.9 ~ 24.1	130 ~ 174
M16 × 1.5	19.9 ~ 26.9	144 ~ 195	26.6 ~ 36.0	192 ~ 260
M18 × 1.5	28.6 ~ 43.6	207 ~ 315	38.4 ~ 52.0	278 ~ 376
M20 × 1.5	40.0 ~ 54.0	289 ~ 391	53.4 ~ 72.2	386 ~ 522
M22 × 1.5	52.7 ~ 71.3	381 ~ 516	70.7 ~ 95.7	511 ~ 692
M24 × 2.0	67.9 ~ 91.9	491 ~ 665	90.9 ~ 123	658 ~ 890
M30 × 2.0	137 ~ 185	990 ~ 1339	182 ~ 248	1314 ~ 1796
M36 × 3.0	192 ~ 260	1390 ~ 1880	262 ~ 354	1894 ~ 2562

2) PIPE AND HOSE

Thread size	Width across flat(mm)	kgf · m	lbf · ft
1/4"	19	3	21.7
3/8"	22	4	28.9
1/2"	27	5	36.2
3/4"	36	12	86.8
1"	41	14	101

3) FITTING

Thread size	Width across flat(mm)	kgf · m	lbf · ft
1/4"	19	4	28.9
3/8"	22	5	36.2
1/2"	27	6	43.4
3/4"	36	13	94.0
1"	41	15	109

4) TIGHTENING TORQUE OF MAJOR COMPONENT

No.	Descriptions	Bolt size	Torque		
			kgf · m	lbf · ft	
1	Engine	Engine mounting bolt, nut	M20 × 2.5	55 ± 3.5	398 ± 25.3
2		Radiator mounting bolt	M12 × 1.75	12.8 ± 3.0	92.5 ± 21.6
3		Main pump housing mounting bolt	M10 × 1.5	6.9 ± 0.3	49.9 ± 2.2
4		Coupling mounting bolt	M16 × 2.0	22.1 ± 2.4	159 ± 17.3
5	Hydraulic system	Main pump mounting bolt	M16 × 2.0	22.1 ± 2.4	159 ± 17.3
6		Main control valve mounting bolt	M12 × 1.75	12.8 ± 3.0	92.5 ± 21.6
7		Fuel tank mounting bolt	M20 × 2.5	46.0 ± 5.1	333 ± 36.9
8		Hydraulic oil tank mounting bolt	M20 × 2.5	46.0 ± 5.1	333 ± 36.9
9		Turning joint mounting bolt, nut	M12 × 1.75	12.2 ± 1.3	88.2 ± 9.4
10	Power train system	Swing motor mounting bolt	M16 × 2.0	29.7 ± 4.5	215 ± 32.5
11		Swing bearing upper mounting bolt	M18 × 2.5	41.3 ± 6.2	299 ± 44.8
12		Swing bearing lower mounting bolt	M16 × 1.5	31.3 ± 4.7	266 ± 34.0
13		Front axle mounting bolt, nut	M20 × 2.5	57.9 ± 8.7	419 ± 63
15		Rear axle mounting bolt, nut	M20 × 2.5	58.0 ± 6.3	420 ± 45.6
16		Transmission mounting bolt	M20 × 2.5	44.0 ± 2.0	318 ± 14.5
17		Oscillating cylinder mounting bolt	M22 × 1.5	83.2 ± 9.2	602 ± 66.5
18		Oscillating cylinder support bolt	M12 × 1.75	12.3 ± 2.5	88.9 ± 18.1
19		Wheel nut	M22 × 1.5	62.0 ± 3.0	448 ± 21.7
20		Front drive shaft mounting bolt, nut	M10 × 1.0	5.9 ± 0.6	42.7 ± 4.3
21		Rear drive shaft mounting bolt, nut	M10 × 1.0	5.9 ± 0.6	42.7 ± 4.3
22	Others	Counter weight mounting bolt	M27 × 3.0	140 ± 15.0	1013 ± 108
23		Cab mounting bolt, nut	M12 × 1.75	12.2 ± 1.3	88.2 ± 9.4
24		Operator's seat mounting bolt	M 8 × 1.25	1.17 ± 0.1	8.5 ± 0.7

3. FUEL, COOLANT AND LUBRICANTS

1) NEW MACHINE

New machine used and filled with following lubricants.

Description	Specification
Engine oil	SAE 15W-40(API CF-4)
Hydraulic oil	ISO VG 46(SAE 10W)
Swing reduction gear oil	SAE 85W-140(API GL-5)
Transmission oil	SAE 10W-30(API CF-4)
Axle differential gear case oil	SAE 85W-90 with LS-ADDITIVE
Axle planetary gear case oil	SAE 85W-140(API GL-5)
Grease	Lithium base grease NLGI No. 2
Fuel	ASTM D975-No. 2
Coolant	Mixture of 50% ethylene glycol base antifreeze and 50% water.

SAE : Society of Automotive Engineers

API : American Petroleum Institute

ISO : International Organization for Standardization

NLGI : National Lubricating Grease Institute

ASTM : American Society of Testing and Material

2) RECOMMENDED OILS

Use only oils listed below or equivalent.

Do not mix different brand oil.

Service point	Kind of fluid	Capacity (U.S. gal)	Ambient temperature °C(°F)						
			-20 (-4)	-10 (14)	0 (32)	10 (50)	20 (68)	30 (86)	40 (104)
Engine oil pan	Engine oil	15.3(4.0)	SAE 30						
			SAE 10W						
Transmission case		3.2(0.85)	SAE 10W-30						
			SAE 15W-40						
Swing drive	Gear oil	2.5(0.66)	SAE 85W-140						
	Grease	0.35(0.09)	NLGI NO.1						
			NLGI NO.2						
Front axle differential gear case	Gear oil	7.75(2.0)	SAE 85W-90						
Rear axle differential gear case		8.4(2.2)							
Axle planetary gear case	Gear oil	1.2(0.32) × 4	SAE 85W-140						
Hydraulic tank	Hydraulic oil	Tank: 124(32.7) System: 240(63.4)	ISO VG 32						
			ISO VG 46						
			ISO VG 68						
Fuel tank	Diesel fuel	270(71.3)	ASTM D975 NO.1						
			ASTM D975 NO.2						
Fitting (Grease nipple)	Grease	As required	NLGI NO.1						
			NLGI NO.2						
Radiator (Reservoir tank)	Mixture of antifreeze and water 50 : 50	24(6.4)	Ethylene glycol base permanent type						

SAE : Society of Automotive Engineers

API : American Petroleum Institute

ISO : International Organization for Standardization

NLGI : National Lubricating Grease Institute

ASTM : American Society of Testing and Material

4. MAINTENANCE CHECK LIST

1) DAILY SERVICE BEFORE STARTING

Check items	Service	Page
Visual check		
Fuel tank	Check, Refill	6-25
Hydraulic oil level	Check, Add	6-29
Engine oil level	Check, Add	6-18
Coolant level	Check, Add	6-20
Control panel & pilot lamp	Check, Clean	6-44
Water separator	Check, Drain	6-26
Fan belt tension	Check, Adjust	6-28

2) EVERY 50 HOURS SERVICE

Check items	Service	Page
Fuel tank(Water sediment)	Drain	6-25
Swing bearing grease	Check, Add	6-33
Drive shaft joint	Check, Add	6-34
Swing reduction gear oil	Check, Add	6-33
Lubricate pin and bushing	Lubricate	6-43
· Boom cylinder tube end		
· Boom foot		
· Boom cylinder rod end		
· Arm cylinder tube end		
· Arm cylinder rod end		
· Boom + Arm connecting		
· Bucket cylinder tube end		
· Bucket cylinder rod end		
· Arm + Bucket connecting		
· Arm + Link, Bucket control		
· Bucket control rod		
· Bucket link connecting		
· Dozer blade cylinder(Rod end, tub end)	Lubricate	6-35
· Dozer blade pivot pin	Lubricate	6-35
· Outrigger(Pivot pin, cylinder pin)	Lubricate	6-35
· Drive shaft(Front and rear)	Lubricate	6-34
· Axle pivot	Lubricate	6-35
· Hub pivot	Lubricate	6-35
· Steering links	Lubricate	6-35

3) INITIAL 50 HOURS SERVICE

Check items	Service	Page
Engine oil	Change	6-18, 19
Engine oil filter	Replace	6-18, 19
Pilot line filter	Replace	6-32
Hydraulic return filter	Replace	6-31
Drain filter cartridge	Replace	6-32
Fuel filter	Replace	6-26
Bolts & Nuts	Check, Tight	6-8
<ul style="list-style-type: none"> · Power train mounting bolts · Swing motor mounting bolts · Swing bearing mounting bolts · Engine mounting bolts · Counterweight mounting bolts · Turning joint locating bolts · Hydraulic pump mounting bolts 		

Service the above items only for the new machine, and thereafter keep the normal service interval.

4) INITIAL 100 HOURS SERVICE

Check items	Service	Page
Transmission oil	Change	6-39

5) EVERY 100 HOURS SERVICE

Check items	Service	Page
Return filter	Replace	6-31
Pilot line filter	Replace	6-32
Element in hydraulic tank breather	Replace	6-31
Drain filter cartridge	Replace	6-32

Replace 4 filters for continuous hydraulic breaker operation only.

6) INITIAL 250 HOURS SERVICE

Check items	Service	Page
Swing reduction gear oil	Change	6-33
Swing reduction grease	Check, Add	6-33

7) EVERY 250 HOURS SERVICE

Check items	Service	Page
Battery electrolyte	Check, Add	6-44
Hydraulic oil return filter	Replace	6-31
Pilot line filter	Replace	6-32
Drain filter cartridge	Replace	6-32
Element in hydraulic tank breather	Replace	6-32
Axle & drive shaft	Lubricate	6-34, 35
Axle oil level	Check, Add	6-37
Transmission oil	Check, Add	6-39
Bolts & Nuts	Check, Tight	6-8
<ul style="list-style-type: none"> · Power train mounting bolts · Swing motor mounting bolts · Swing bearing mounting bolts · Engine mounting bolts · Counterweight mounting bolts · Turning joint locating bolts · Hydraulic pump mounting bolts 		

★ If you use high sulfur containing fuel above than 0.5% or use low grade of engine oil reduce change interval.

8) INITIAL 500 HOURS SERVICE

Check items	Service	Page
Axle oil	Change	6-38

9) EVERY 500 HOURS SERVICE

Check items	Service	Page
★Engine oil	Change	6-18, 19
★Engine oil filter	Replace	6-18, 19
Radiator and cooler fin	Check, Clean	6-23
☆Air cleaner element(Primary)	Inspect, Clean	6-25
Fuel filter	Replace	6-26

★ If you use high sulfur containing fuel above than 0.5% or use low grade of engine oil reduce change interval.

☆ Clean the primary element only after 500 hours operation or when the air cleaner warning lamp blinks. Replace primary element and safety element after 4 times cleanings of primary element.

10) EVERY 1000 HOURS SERVICE

Check items	Service	Page
Swing reduction gear oil	Change	6-33
Swing reduction grease	Refill	6-33
Grease in swing gear and pinion	Change	6-33
Axle oil	Change	6-38
Transmission oil	Change	6-39

11) EVERY 2000 HOURS SERVICE

Check items	Service	Page
Hydraulic tank		
· Oil	Change	6-31
· Suction strainer	Check, Clean	6-31
Coolant	Change	6-20, 21, 22, 23

Change oil every 600 hours of continuous hydraulic breaker operation.

12)WHEN REQUIRED

Whenever you have trouble in the machine, you must perform the service of related items, system by system.

Check items	Service	Page
Fuel system		
· Fuel tank	Drain or Clean	6-25
· Water separator	Drain or Replace	6-26
· Fuel filter	Replace	6-26
Engine lubrication system		
· Engine oil	Change	6-18, 19
· Engine oil filter	Replace	6-18, 19
Engine cooling system		
· Coolant	Add or Change	6-20, 21, 22, 23
· Radiator	Clean or Flush	6-20, 21, 22, 23
Engine air system		
· Air cleaner	Replace	6-25
Hydraulic system		
· Hydraulic oil	Add or Change	6-30
· Return filter	Replace	6-31
· Drain line filter	Replace	6-32
· Pilot line filter	Replace	6-32
· Element of breather	Replace	6-32
· Suction strainer	Clean	6-31
Tire pressure	Check, Inflate	6-36
Bucket		
· Tooth	Replace	6-41
· Side cutter	Replace	6-41
· Linkage	Adjust	6-40
· Bucket assy	Replace	6-40
Air conditioner and heater		
· Fresh filter	Clean, Replace	6-47
· Recirculation filter	Clean	6-48

5. MAINTENANCE CHART

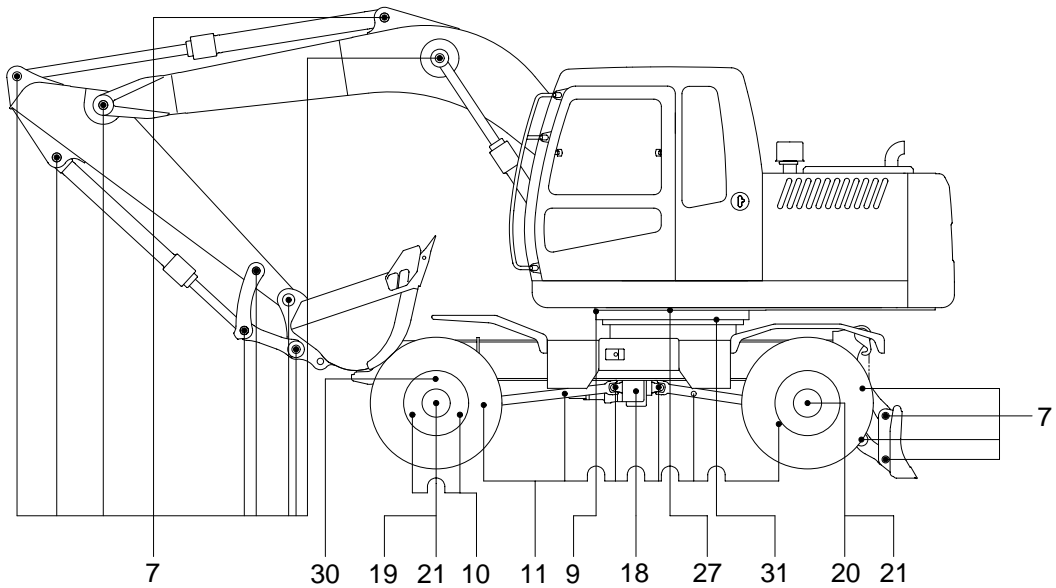
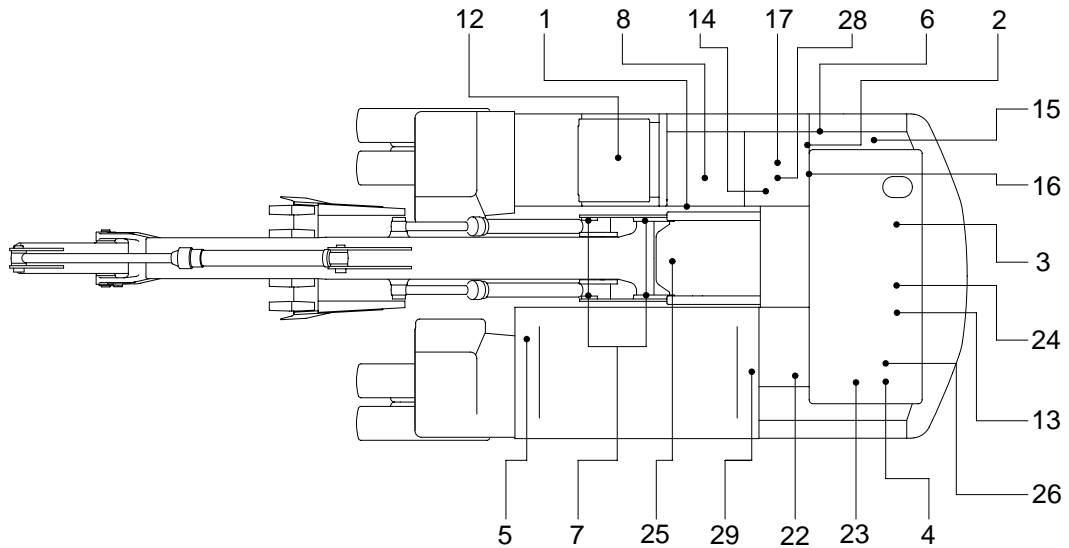

140W76M103

Caution

1. Service intervals are based on the hour meter reading.
2. The number of each item shows the lubrication point on the machine.
3. Stop engine while filling oil, and use no open flames.
4. For other details, refer to the service manual.

Service interval	No.	Description	Service action	Oil symbol	Capacity l (U.S.gal)	Service points No.
10Hours or daily	1	Fuel tank	Check, Refill	DF	270(71.3)	1
	2	Hydraulic oil level	Check, Add	HO	124(32.7)	1
	3	Engine oil level	Check, Add	EO	15.3(4.0)	1
	4	Radiator coolant level	Check, Add	C	24(6.4)	1
	5	Control panel and pilot lamp	Check, Clean	-	-	1
	6	Water separator	Check, Drain	-	-	2
	7	Fan belt tension & damage	Check, Adjust	-	-	1
50 Hours or weekly	8	Attachment pins	Check, Add	PGL	-	See note
	9	Fuel tank strainer and drain	Check, Clean	-	-	1
	10	Swing bearing grease	Check, Add	PGL	-	3
	11	Drive shaft(joint)	Check, Add	PGL	-	6
	12	Transmission case	Check, Add	EO	3.2(0.85)	1
	13	Swing reduction gear case	Check, Add	GO(1)	2.5(0.66)	1
	14	Swing drive gear case	Check, Add	PGL	0.35(0.09)	1
250 Hours	15	Front axle trunnion bushing	Check, Add	PGL	-	2
	16	Battery(Electrolyte, voltage)	Check	-	-	2
	17	Hydraulic oil return filter	Replace	-	-	1
	18	Pilot line filter element	Replace	-	-	1
	19	Drain filter cartridge	Replace	-	-	1
	20	Air breather element	Replace	-	-	1
	21	Front axle differential gear case	Check, Add	GO(2)	-	1
	22	Rear axle differential gear case	Check, Add	GO(2)	-	1
	23	Axle planetary gear case(Front, rear)	Check, Add	GO(2)	-	4
	24	Front axle steering case	Check, Add	PGL	-	2
500 Hours	3	Engine oil level	Change	EO	15.3(4.0)	1
	25	Engine oil filter	Replace	-	-	1
	26	Air cleaner element(Primary)	Check, Clean	-	-	2
	27	Radiator and cooler fin	Check, Clean	-	-	1
	28	Fuel filter element	Replace	-	-	1
1000 Hours	12	Transmission case	Change	EO	3.2(0.85)	1
	13	Swing reduction gear case	Change	GO(1)	2.5(0.66)	1
	21	Front axle case	Change	GO(2)	7.75(2.0)	1
	22	Rear axle case	Change	GO(2)	8.4(2.2)	1
	23	Axle planetary gear case(Front, rear)	Change	GO	1.2(0.32)	4
	29	Swing gear and pinion	Change	PGL	4.4(1.2)	1
2000 Hours	2	Hydraulic tank oil level	Change	HO	124(32.7)	1
	4	Radiator coolant level	Change	C	24(6.4)	1
	30	Hydraulic oil suction strainer	Check, Clean	-	-	1
As required	31	Air conditioner filters	Check, Clean	-	-	2

Note : Pins of boom : Mono boom(17), Two pieces boom(20)

Pins of lower frame : Dozer blade(12), Outrigger(8)

★ Severely dusty area operation only.

※ Oil symbol

Please refer the recommended lubricants for specification.

DF : Diesel fuel GO(1) : Gear oil(SAE 85W-140) GO(2) : Gear oil(SAE 85W-90 LSD)

HO : Hydraulic oil C : Coolant PGL : Grease EO : Engine oil

6. SERVICE INSTRUCTION

1) CHECK ENGINE OIL LEVEL

Check the oil level with the machine on a flat ground before starting engine.

- (1) Pull out the dipstick and wipe with a clean cloth.
- (2) Check the oil level by inserting the dipstick completely into the hole and pulling out again.
- (3) If oil level is LOW, add oil and then check again.
 - ※ If the oil is contaminated or diluted, change the oil regardless of the regular change interval.
 - ※ Check oil level after engine has been stopped for 15 minutes.
 - ▲ Do not operate unless the oil level is in the normal range.

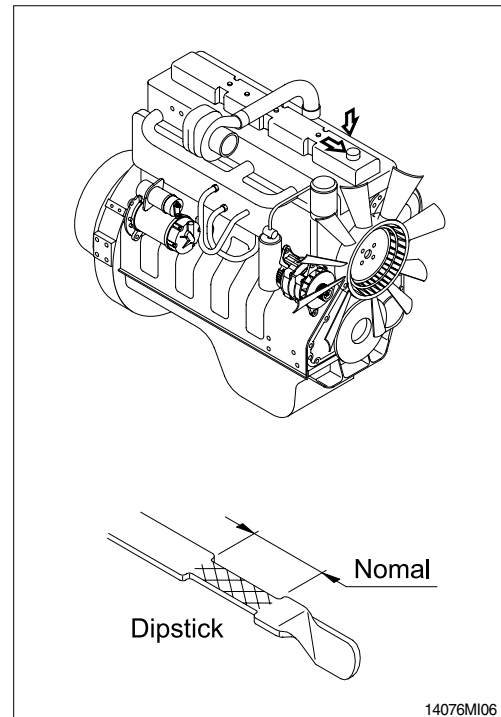

2) REPLACEMENT OF ENGINE OIL AND OIL FILTER

- (1) Warm up the engine.
- (2) Turn the lever to open position.
 - ※ A drain pan with a capacity of 23 liters (6.0U.S. gallons) will be adequate.
- (3) Clean around the filter head, remove the filter and clean the gasket surface.
 - Wrench size : 90 ~ 95mm(3.5~3.8in)

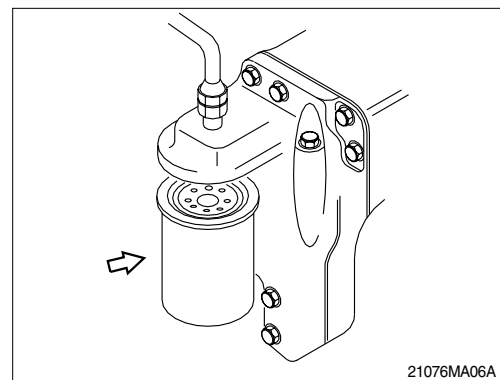
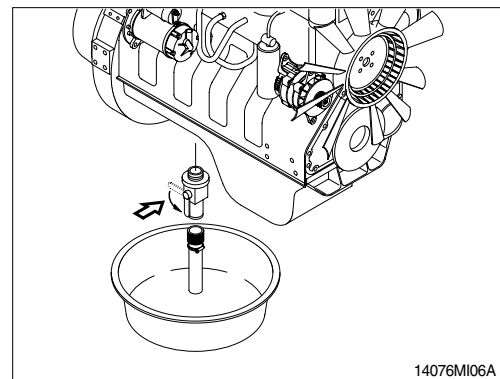

- (4) Apply a light film of lubricating oil to the gasket sealing surface before installing the filters.
Fill the filters with clean lubricating oil.

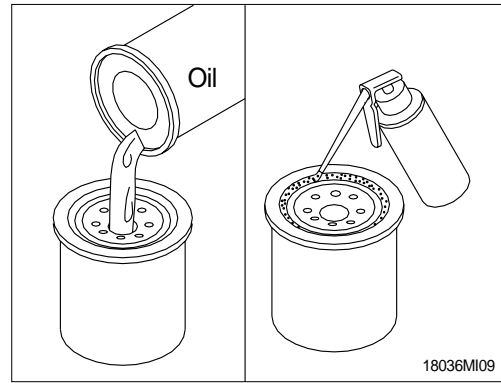

- (5) Install the filter to the filter head.
Mechanical over-tightening may distort the threads or damage the filter element seal.
· Install the filter as specified by the filter manufacturer.

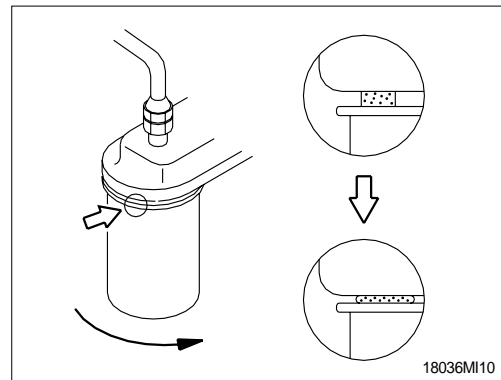

- (6) Fill the engine with clean oil to the proper level.
· Quantity : 15.3 (4.0U.S.gallons)

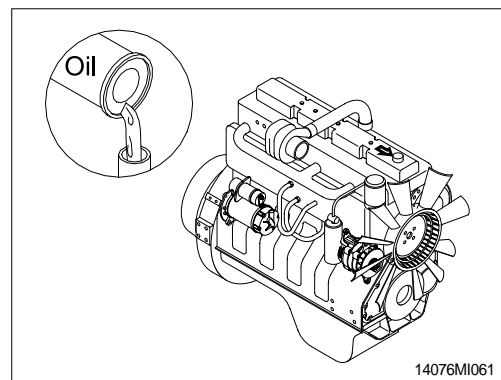

- (7) Operate the engine at low idle and inspect for leaks at the filters and the drain plug.
Shut the engine off and check the oil level with the dipstick. Allow 15minutes for oil to drain down before checking.

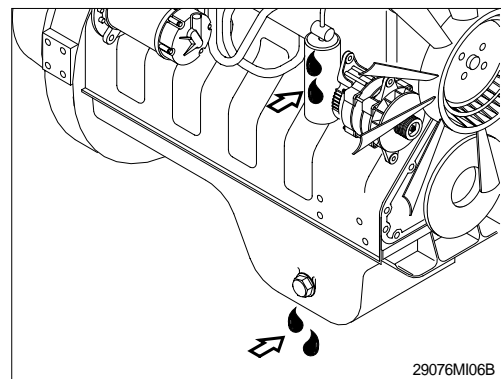

3) CHECK COOLANT

- (1) Check if the level of coolant in reservoir tank is between FULL and LOW.
- (2) Add the mixture of antifreeze and water after removing the cap of the reservoir tank if coolant is not sufficient.
- (3) Be sure to use the reservoir empty, add the coolant by opening the cap of radiator.
- (4) Replace gasket of radiator cap when it is damaged.

▲ Hot coolant can spray out if radiator cap is removed while engine is hot. Remove the cap after the engine has cooled down.

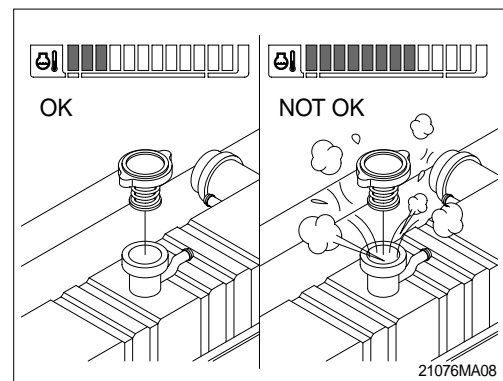
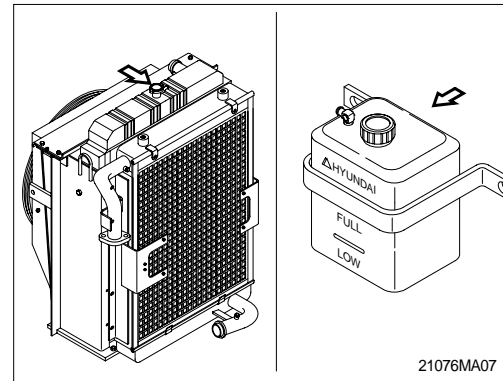

4) FLUSHING AND REFILLING OF RADIATOR

(1) Change coolant

▲ Avoid prolonged and repeated skin contact with used antifreeze. Such prolonged repeated contact can cause skin disorders or other bodily injury.

Avoid excessive contact-wash thoroughly after contact.

Keep out of reach of children.

Protect the environment : Handling and disposal of used antifreeze can be subject to federal, state, and local law regulation.

Use authorized waste disposal facilities, including civic amenity sites and garages providing authorized facilities for the receipt of used antifreeze.

If in doubt, contact your local authorities for guidance as to proper handling of used antifreeze.

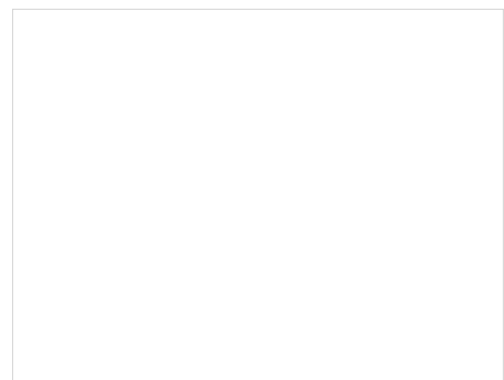
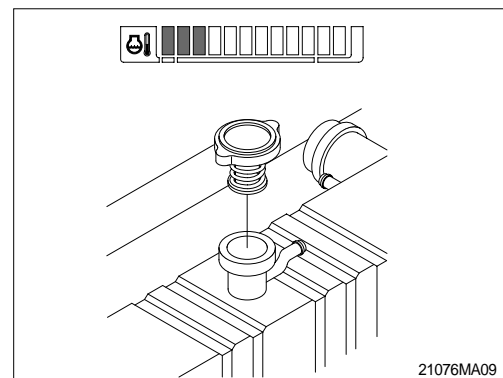

▲ Wait until the temperature is below 50°C (120°F) before removing the coolant system pressure cap.

Failure to do so can cause personal injury from heated coolant spray.

Drain the cooling system by opening the drain valve on the radiator and removing the plug in the bottom of the water inlet. A drain pan with a capacity of 40 liters(10U.S.gallons) will be adequate in most applications.

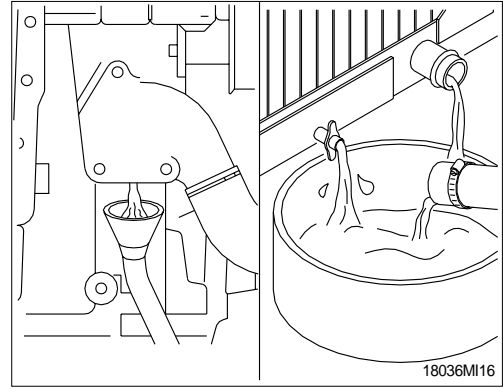

(2) Flushing of cooling system

Fill the system with a mixture of sodium carbonate and water(or a commercially available equivalent).

Use 0.5kg(1.0pound) of sodium carbonate for every 23 liters(6.0U.S. gallons) of water.

Do not install the radiator cap. The engine is to be operated without the cap for this process.

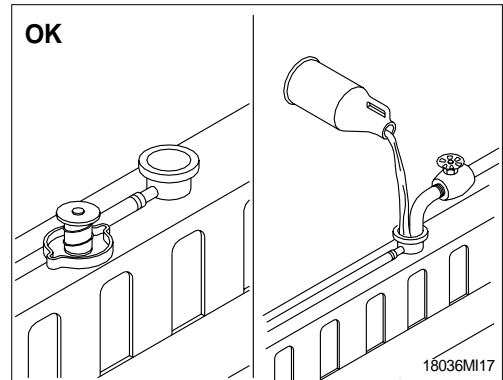

During filling, air must be vented from the engine coolant passages. Open the engine venting petcock.

The system must be filled slowly to prevent air locks. Wait 2 to 3 minutes to allow air to be vented, then add mixture to bring the level to the top.

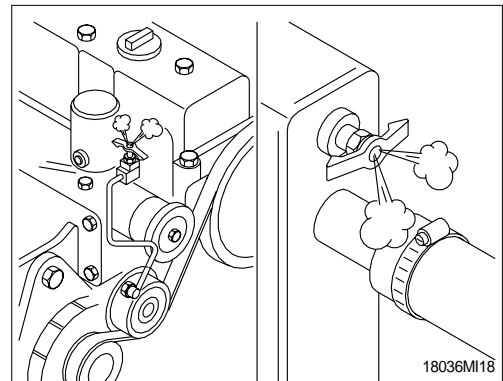

Operate the engine for 5 minutes with the coolant temperature above 80°C(176°F) .

Shut the engine off, and drain the cooling system.

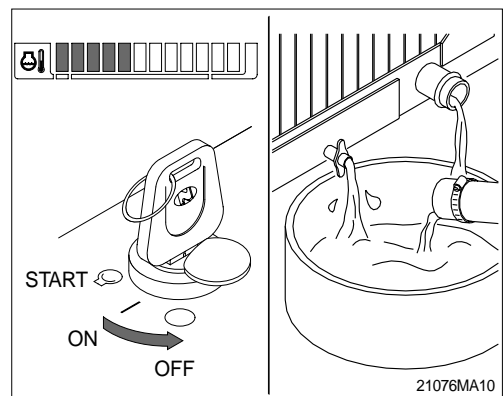

Fill the cooling system with clean water.

Be sure to vent the engine and aftercooler for complete filling.

Do not install the radiator cap or the new coolant filter.

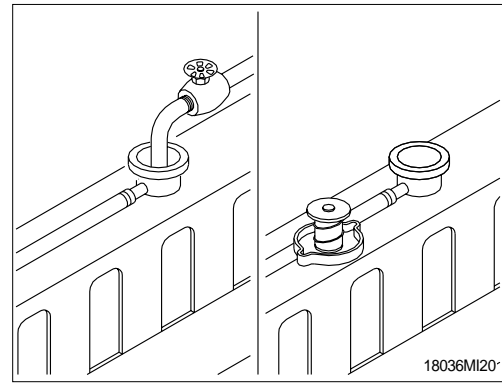

Operate the engine for 5 minutes with the coolant temperature above 80°C(176°F) .

Shut the engine off, and drain the cooling system.

If the water being drained is still dirty, the system must be flushed again until the water is clean.

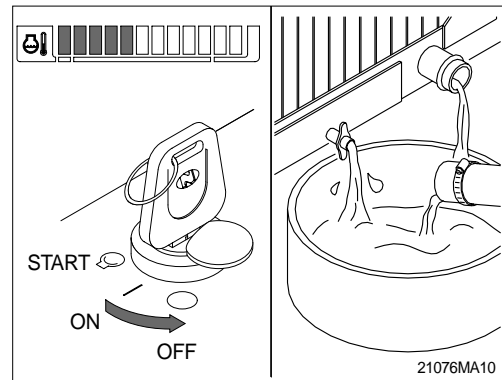

(3) Cooling system filling

Use a mixture of 50 percent water and 50 percent ethylene glycol antifreeze to fill the cooling system.

Coolant capacity(engine only) : 8.3 (2.2U.S. gallons)

Use the correct amount of DCA4 corrosion inhibitor to protect the cooling system.

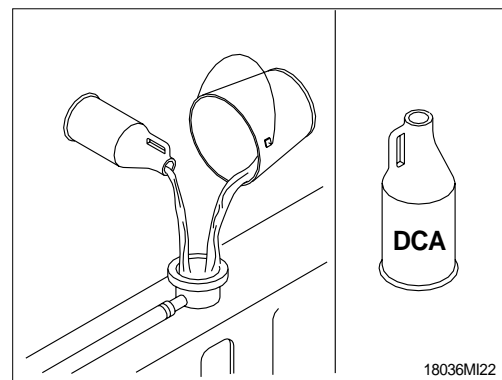

The system has a maximum fill rate of 14 liters(3.5U.S. gallons) per minute.

Do not exceed this fill rate.

The system must be filled slowly to prevent air locks.

During filling, air must be vented from the engine coolant passage.

Be sure to open the petcock.

Then add mixture to bring the level to the top.

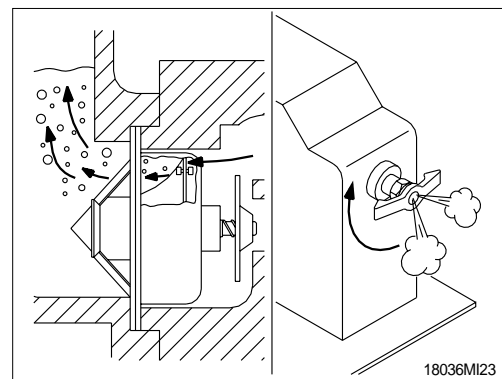

Install the pressure cap. Operate the engine until it reaches a temperature 80°C(176°F), and check for coolant leaks.

Check the coolant level again to make sure the system is full of coolant.

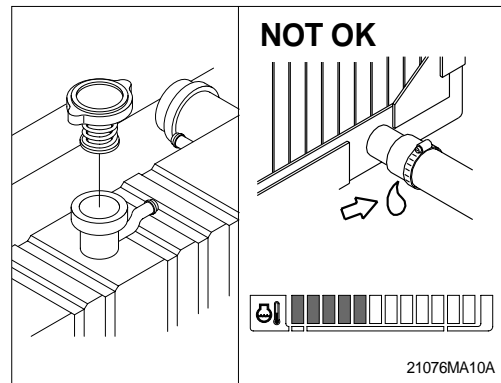

5) CLEAN RADIATOR AND OIL COOLER

Check, and if necessary, clean and dry outside of radiator and oil cooler. After working in a dusty place, clean radiator more frequently.

- (1) Visually inspect the radiator for clogged radiator fins.
- (2) Use 550kPa(80psi) air pressure to blow the dirt and debris from the fins.
Blow the air in the opposite direction of the fan air flow.

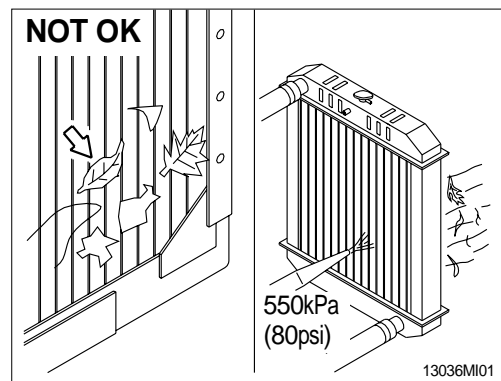

- (3) Visually inspect the radiator for bent or broken fins.

If the radiator must be replaced due to bent or broken fins which can cause the engine to overheat, refer to the manufacturer's replacement procedures.

- (4) Visually inspect the radiator for core and gasket leaks.

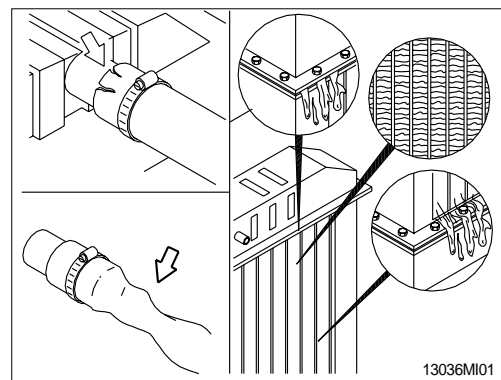

6) CHECK CHARGE AIR COOLER

Inspect the charge air cooler for dirt and debris blocking the fins. Check for cracks, holes, or other damage. If damage is found, please contact Hyundai distributor.

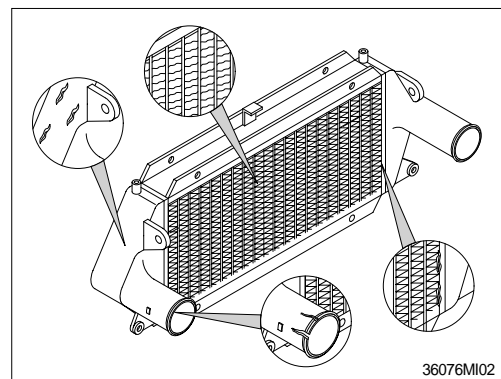

7) FAN BELT TENSION

- (1) Measure the belt deflection at the longest span of the belt.
 - Maximum deflection : 9.5 - 12.7mm
(3/8 to 1/2inch)

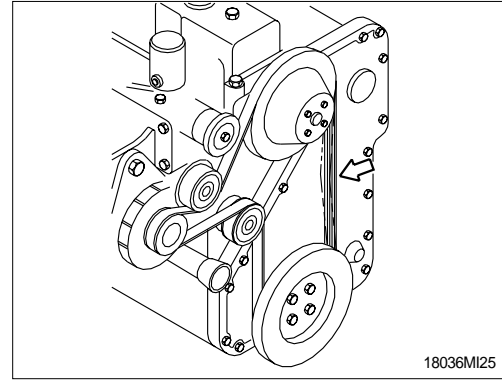

- (2) Inspect the drive for damage.

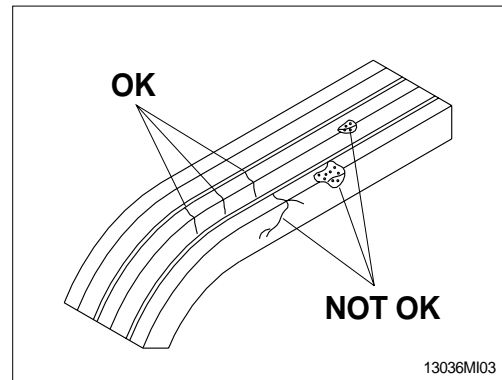

- (3) Inspect the drive belt, tension bearing and fan hub.

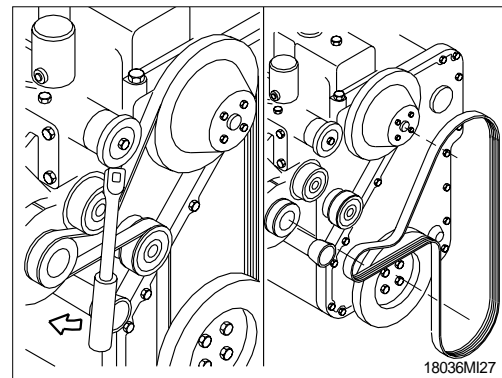

8) INSPECTION OF COOLING FAN

- ▲ **Personal injury can result from a fan blade failure. Never pull or pry on the fan. This can damage the fan blade and cause fan failure. Rotate the crankshaft by using the engine barring gear.**
- A visual inspection of the cooling fan is required daily.**
- Check for cracks, loose rivets, and bent or loose blades.**
- Check the fan to make sure it is securely mounted. Tighten the capscrews if necessary. Replace any fan that is damaged.**

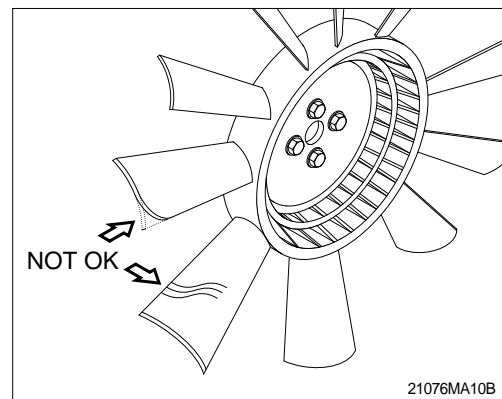

9) CLEANING OF AIR CLEANER

(1) Primary element

Loosen the wing nut and remove the element.

Clean the inside of the body.

Clean the element with pressurized air.

- Remove the dust inside of the element by the pressurized air (Below 3kgf/cm^2 , 40psi) forward and backward equally.

Inspect for cracks or damage of element by putting a light bulb inside of the element.

Insert element and tighten wing nut.

Replace the primary element after 4 times cleanings.

(2) Safety element

Replace the safety element only when the primary element is cleaned for the 4 times.

Always replace the safety element. Never attempt to reuse the safety element by cleaning the element.

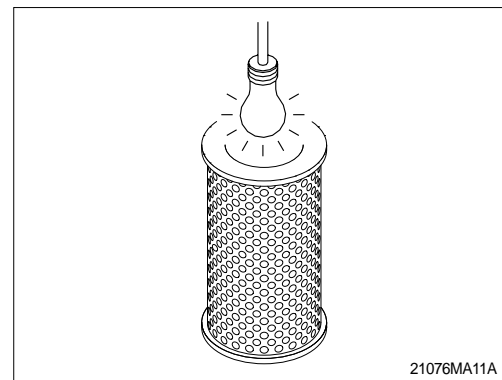
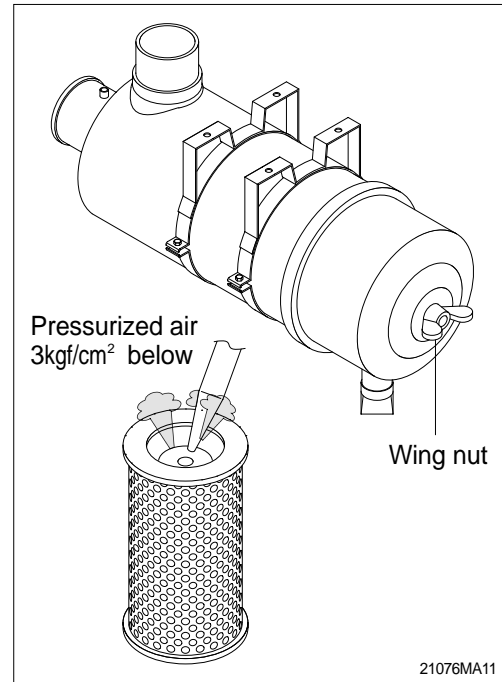

10) FUEL TANK

- (1) Fill fuel fully when system the operation to minimize water condensation, and check it with fuel gauge before starting the machine.

- (2) Drain the water and sediment in the fuel tank by opening the drain cock.

Be sure to LOCK the cap of fuel tank.

Remove the strainer of the fuel tank and clean it if contaminated.

⚠ Stop the engine when refueling.

All lights and flames shall be kept at a safe distance while refueling.

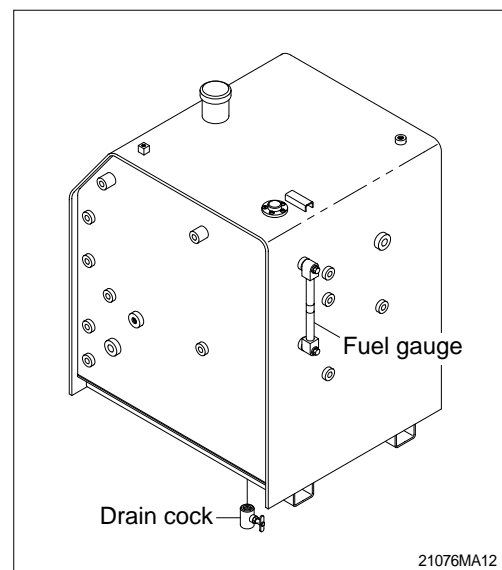

11) WATER SEPARATOR

- (1) Drain the water and sediment by loosening the drain plug.
- (2) Retighten the drain plug.
- (3) Check for leakage.
Drain the water if it reaches the red line regardless of the service interval.
Bleed the air if the air is mingled on the fuel line when draining water.

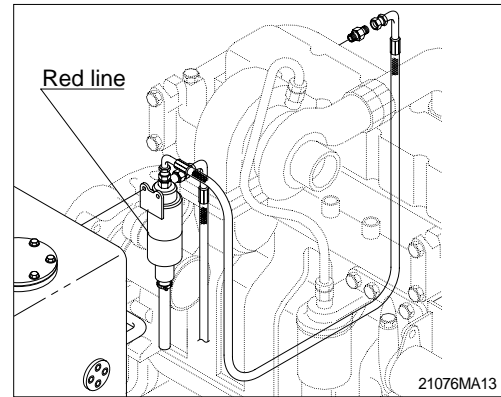

12) REPLACEMENT OF FUEL FILTER

- (1) Clean around the filter head, remove the filter and clean the gasket surface.
 - Wrench size : 90~95mm(3.5~3.8in)
- (2) Replace the O-ring.
- (3) Fully fill fuel in the new filter.
- (4) Apply engine oil on the gasket of filter when mounting, and tighten 3/4 to 1 turn more after the gasket touches the filter head.
- (5) Relieve the air after mounting.
Check for fuel leakage after the engine starts.
If air is in the fuel system, the engine will not start. Start engine after bleeding the air according to the method of bleeding air.

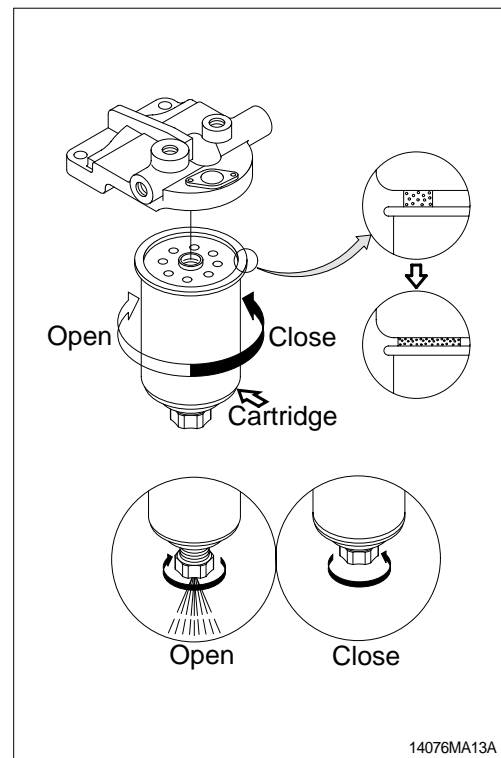

FUEL WATER SEPARATOR

- Drain the water and sediment from the separator daily.
- Shut off the engine.
- Use your hand to open the drain valve.
- Turn the valve counterclockwise 4 complete turns until the valve drops down 1".
- Drain the filter sump of water until clear fuel is visible.
Do not overtighten the valve.
Overtightening can damage the threads.
- Push the valve up and turn the valve clockwise to close the drain valve.
If more than 2 ozs is drained, refilling of the filter is required to prevent hard starting.
Refer to low pressure lines and fuel filter venting clause 12)-(2).

13) BLEEDING THE FUEL SYSTEM

(1) Controlled venting is provided at the injection pump through the fuel drain manifold. Small amounts of air introduced by changing the filters or injection pump supply line will be vented automatically, if the fuel filter is changed in accordance with the instructions.

However, manual bleeding will be required if :

- **The fuel filter is not filled prior to installation.**
- **Injection pump is replaced.**
- **High pressure fuel lines are replaced.**

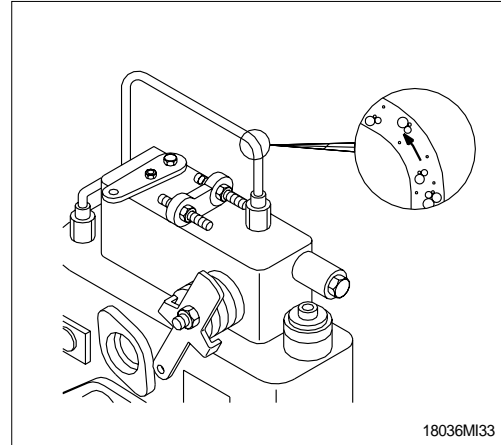

(2) Venting the low pressure lines and fuel filter

Open the bleed screw.

- Wrench size : 8mm

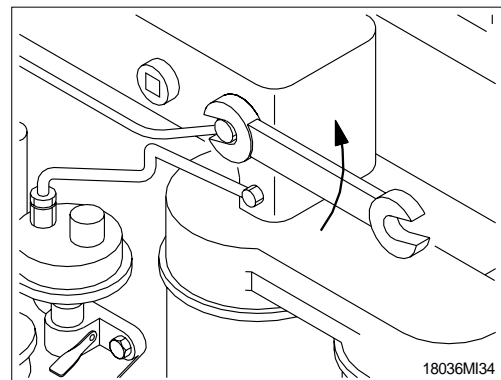

Operate the hand lever until the fuel flowing from the fitting is free of air.

Tighten the bleed screw.

- Torque : 0.97kgf · m(7lbf · ft)

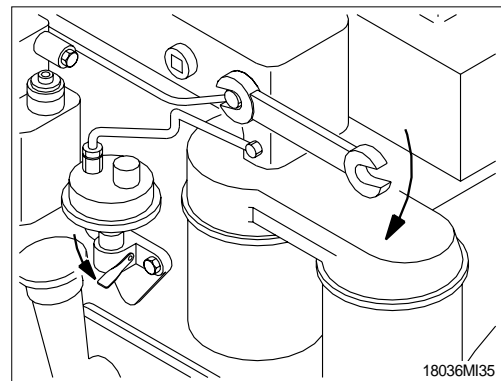

(3) Venting at the injection pumps

Bleed the Lucas CAV pump in this illustration.

- Wrench size : 8mm

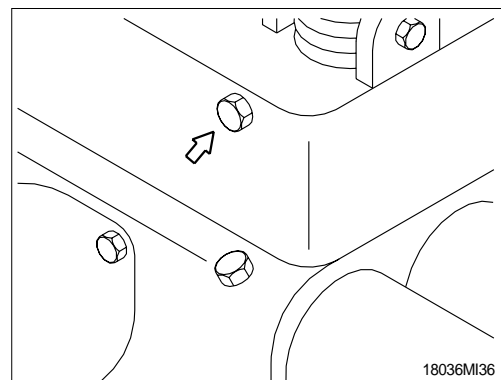

14) BELT TENSIONER, AUTOMATIC ADJUSTMENT

- (1) Every 1000hours, or 1 year, whichever occurs first, inspect the automatic belt tensioner.

With the engine turned off, check that neither the top nor bottom tensioner arm stop is touching the cast boss on the tensioner body. If either of the stops is touching a boss, the alternator belt must be replaced. Check to make sure the correct belt part number is being used if either condition exists.

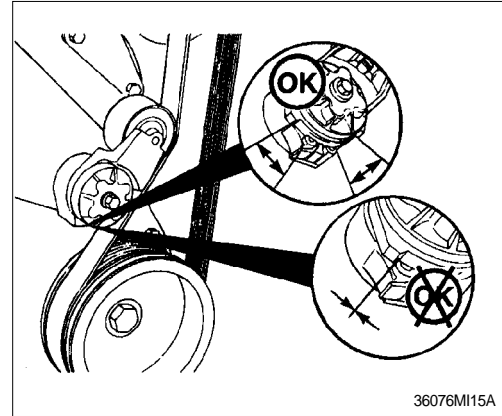

- (2) Check the tensioner pulley and body for cracks. If any cracks are noticed, the tensioner must be replaced. Refer to a Cummins Authorized Repair facility. Check the tensioner for dirt buildup. If this condition exists, the tensioner must be removed and steam-cleaned.

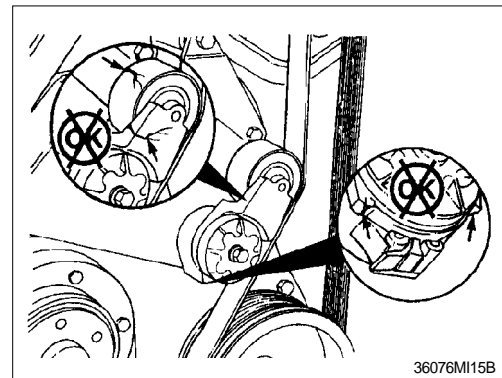

- (3) Check that the bottom tensioner arm stop is in contact with the bottom tensioner arm stop boss on the tensioner body. If these two are not touching, the tensioner must be replaced.

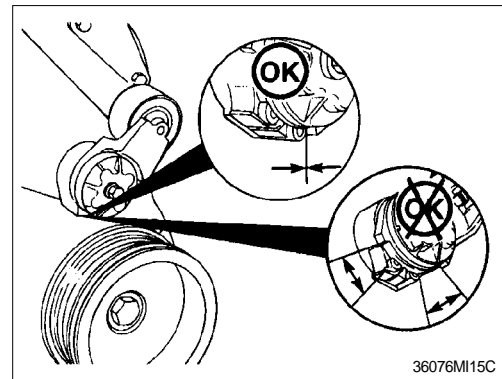

- (4) Inspect the tensioner for evidence of the pivoting tensioner arm contacting the stationary circular base. If there is evidence of these two areas touching, the pivot tube bushing has failed and the tensioner must be replaced.

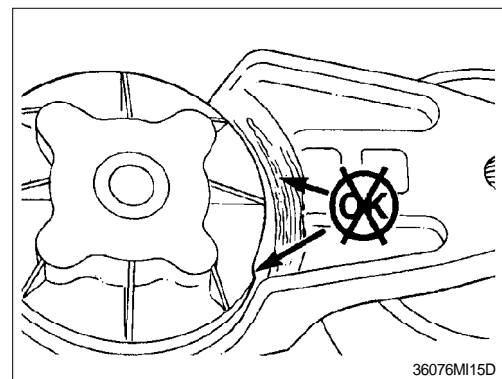

- (5) A worn tensioner that has play in it or a belt that “walks” off its pulley possibly indicates pulley misalignment.

Maximum pulley mislignment is three degrees. This measurement can be taken with a straightedge and an inclinometer.

- (6) Install the belt.

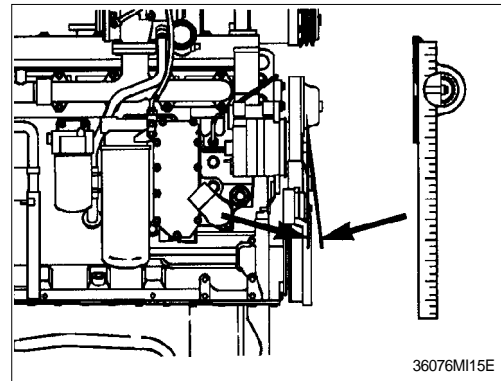

15) LEAKAGE OF FUEL

- ▲ Be careful and clean the fuel hose, injection pump, fuel filter and other connections as the leakage from these part can cause fire.**

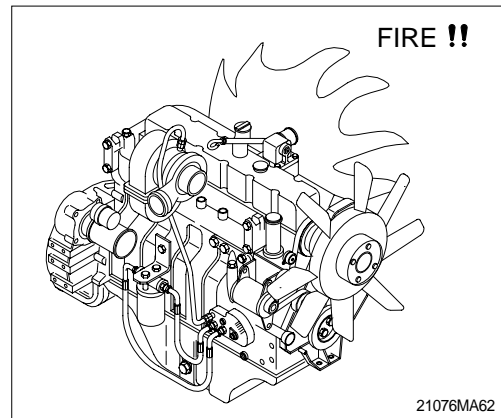

16) HYDRAULIC OIL CHECK

- (1) Stop the engine after retract the arm and bucket cylinders, then lower the boom and set the bucket on the ground at a flat location as in the illustration.
- (2) Check the oil level at the level gauge of hydraulic oil tank.
- (3) The oil level is normal if between the red lines.

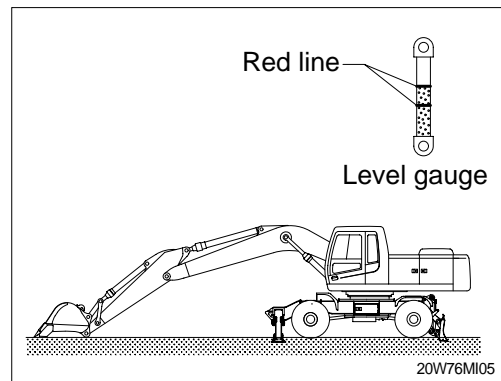

17) FILLING HYDRAULIC OIL

- (1) Stop the engine to the position of level check.
- (2) Loosen the cap and relieve the pressure in the tank by pushing the top of the air breather.
- (3) Remove the breather on the top of oil tank and fill the oil to the specified level.
 - Tightening torque : $1.44 \pm 0.3 \text{kgf} \cdot \text{m}$
($10.4 \pm 2.1 \text{lbf} \cdot \text{ft}$)
- (4) Start engine after filling and operate the work equipment several times.
- (5) Check the oil level at the level check position after engine stops.

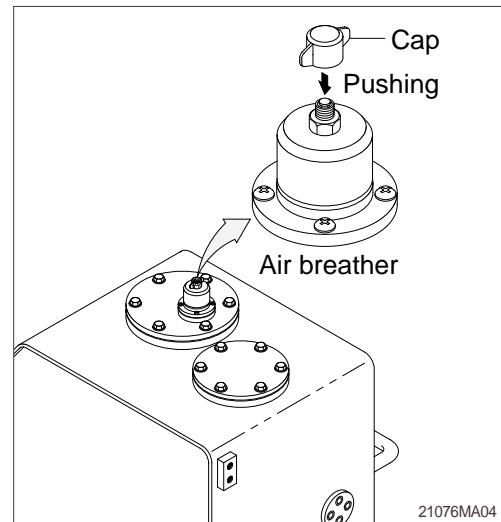

18) CHANGE HYDRAULIC OIL

- (1) Lower the bucket on the ground pulling the arm and bucket cylinder to the maximum.
- (2) Loosen the cap and relieve the pressure in the tank by pushing the top of the air breather.
- (3) Remove the cover.
 - Tightening torque : $6.9 \pm 1.4 \text{kgf} \cdot \text{m}$
($50 \pm 10 \text{lbf} \cdot \text{ft}$)
- (4) Prepare a suitable container.
- (5) To drain the oil loosen the drain plug at the bottom of the oil tank.
- (6) Fill proper amount of recommended oil.
- (7) Put the breather in the right position.
- (8) Bleed air hydraulic pump loosen the air breather at top of hydraulic pump assembly.**
- (9) Start engine and run continually. Release the air by full stroke of each control lever.

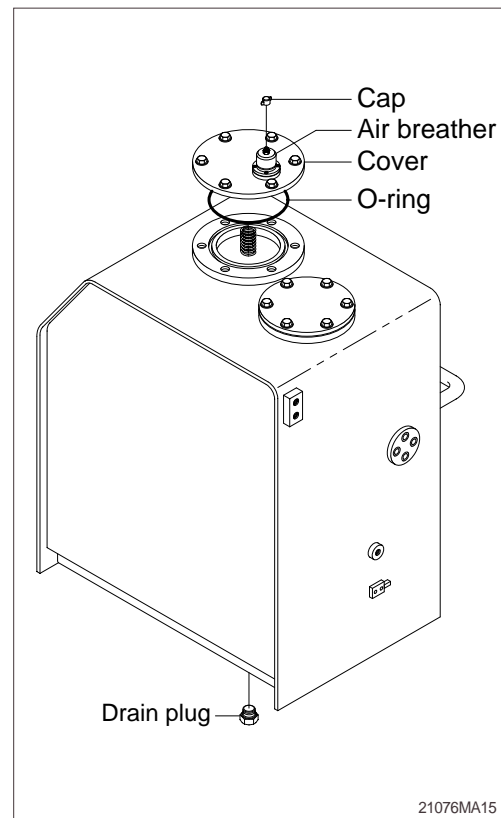

19) CLEAN SUCTION STRAINER

Clean suction strainer as follows paying attention to the cause to be kept during oil filling.

- (1) Remove the cover on the top of the oil tank.
 - Tightening torque : $6.9 \pm 1.4\text{kgf} \cdot \text{m}$
($50 \pm 10\text{lbf} \cdot \text{ft}$)
- (2) Pull out the strainer in the tank.
- (3) Wash the foreign material on the suction strainer with gasoline or cleaning oil.
- (4) Replace the suction strainer if it is damaged.
- (5) Assemble with reverse order of disassembly.
Be sure to install a new O-ring and reinsert in the oil tank.

Loosen the bolt slowly at the cover can be spring out by the spring when removing it.

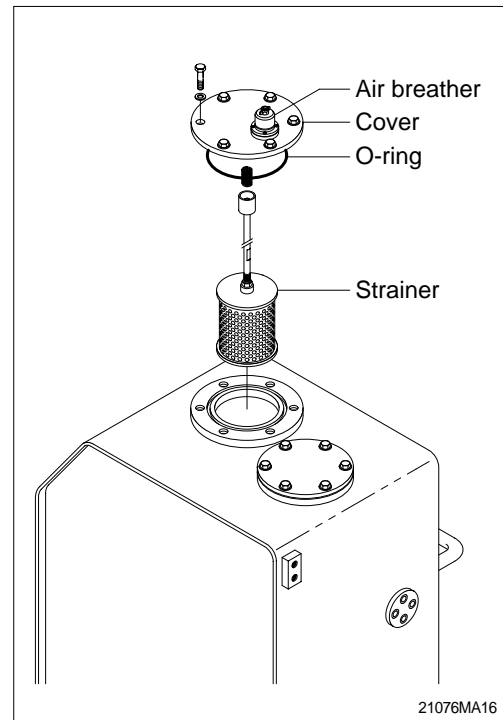

20) REPLACEMENT OF RETURN FILTER

Replace as follows paying attention to the cause to be kept during the replacement.

- (1) Remove the cover.
 - Tightening torque : $6.9 \pm 1.4\text{kgf} \cdot \text{m}$
($50 \pm 10\text{lbf} \cdot \text{ft}$)
- (2) Remove the spring, by-pass valve, and return filter in the tank.
- (3) Replace the element with new one.

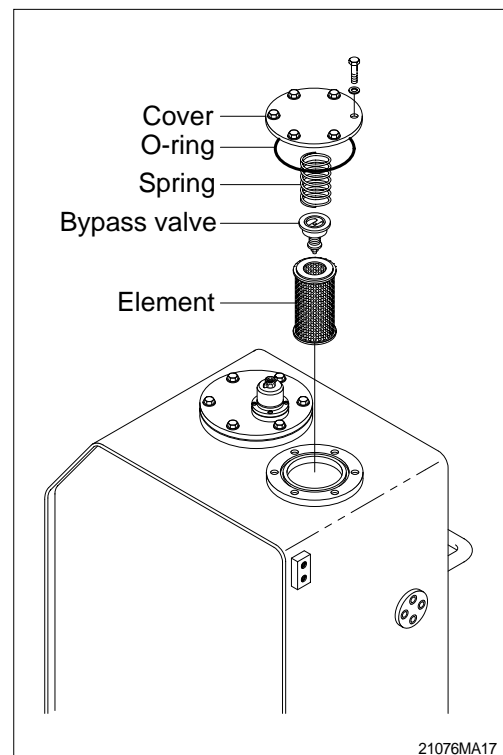

21) REPLACEMENT OF ELEMENT IN HYDRAULIC TANK BREATHER

- (1) Loosen the cap and relieve the pressure in the tank by pushing the top of the air breather.
- (2) Loosen the lock nut and remove the cover.
- (3) Pull out the filter element.
- (4) Replace the filter element new one.
- (5) Apply oil on the O-ring and reassemble by reverse order of disassembly.
 - Tightening torque : 0.2~0.3kgf · m
(1.4~2.1lbf · ft)

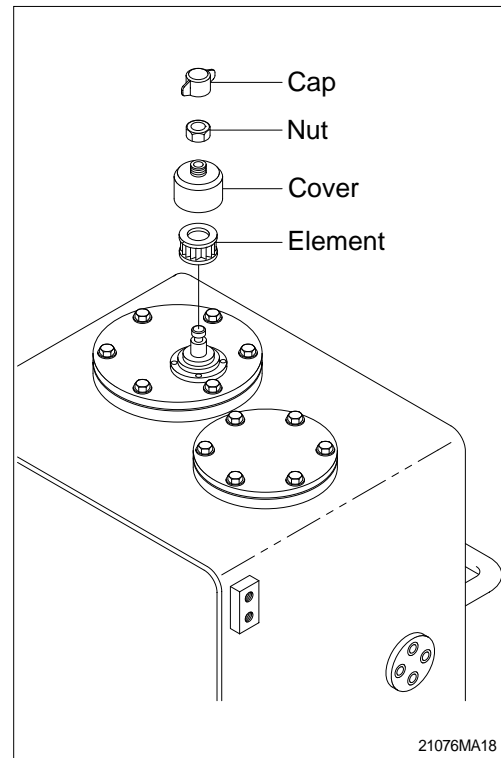

22) REPLACE OF DRAIN FILTER CARTRIDGE

Clean the dust around filter and replace with new one after removing the cartridge.

Tighten about 2/3 turn more after the gasket of cartridge contacts seal side of filter body for mounting.

Change cartridge after initial 50 hours of operation. Thereafter, change cartridge every 250 hours.

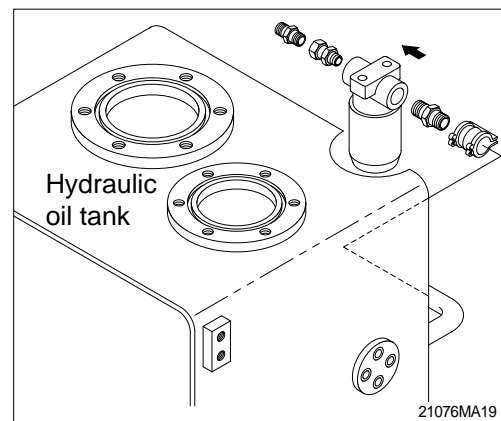

23) REPLACE OF PILOT LINE FILTER

- (1) Loosen the nut positioned on the filter body.
- (2) Pull out the filter element and clean filter housing.
- (3) Install the new element and tighten using specified torque.
 - Change cartridge after initial 50 hours of operation. Thereafter, change cartridge every 250 hours.**

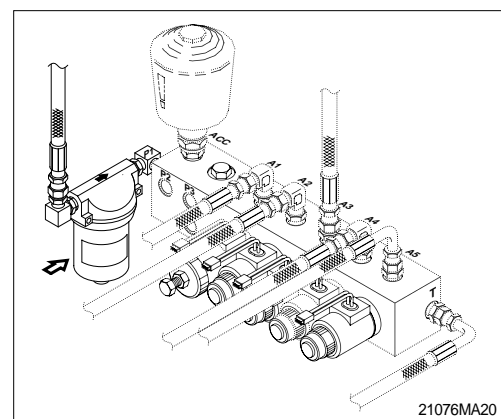

24) CHECK THE SWING REDUCTION GEAR OIL

- (1) Pull out the dipstick and clean it.
- (2) Insert it again.
- (3) Pull out one more time to check the oil level and fill the oil if the level is not sufficient.

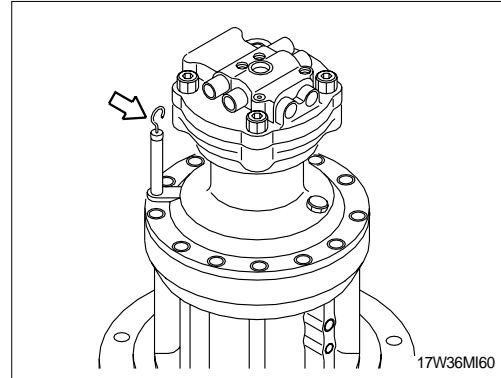

25) CHANGE SWING REDUCTION GEAR OIL

- (1) Raise the temperature of oil by swinging the machine before replace the oil and park the machine on the flat ground.
 - (2) Loosen the plug of the drain port.
 - (3) Drain into a proper container.
 - (4) Wash the drain plug and reinstall it with sealing tape.
- Fill proper amount of recommended oil.
- Amount of oil : 2.5 (0.66U.S.gal)

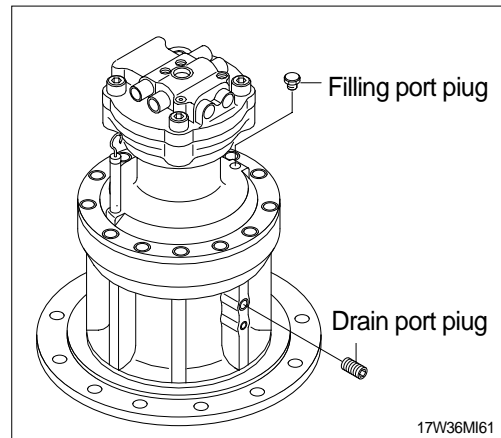

26) LUBRICATE BEARING OF OUTPUT SHAFT IN REDUCTION GEAR

- (1) Remove air vent plug.
 - (2) Remove grease fill plug and install grease fitting at that place.
 - (3) Lubricate NLGI No.2 with grease gun until comes out new grease from air vent port.
- Lubricate every 1000 hours.**
- Amount of grease : 0.35 (0.09U.S.gal)

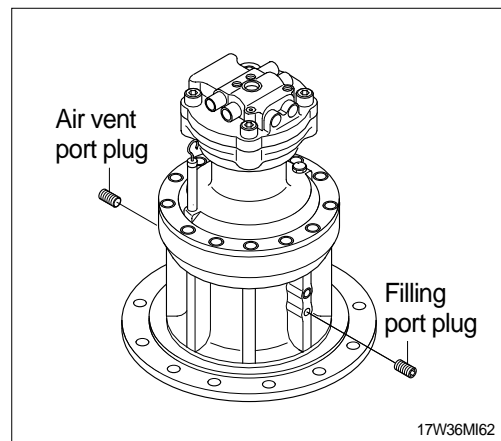

27) LUBRICATE SWING BEARING

- (1) Grease at 3 fitting.
- Lubricate every 50 hours.**

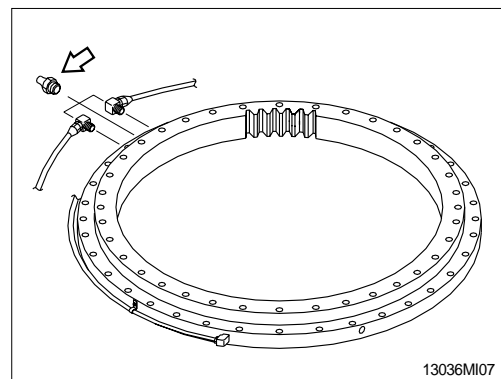

28) SWING GEAR AND PINION

(1) Drain old grease

- Remove under cover of lower frame.
- Remove drain cover of lower frame.
- Remove filler cover of upper frame.
- Operate full turn(360°) of swing several times.

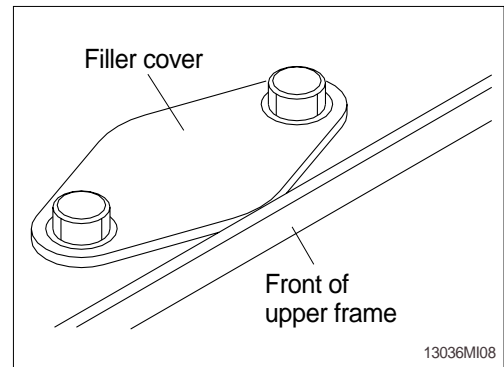

(2) Refill new grease

- Install drain cover.
- Fill with new grease.
- Install filler cover.
- Capacity : 3.9kg(8.6lb)

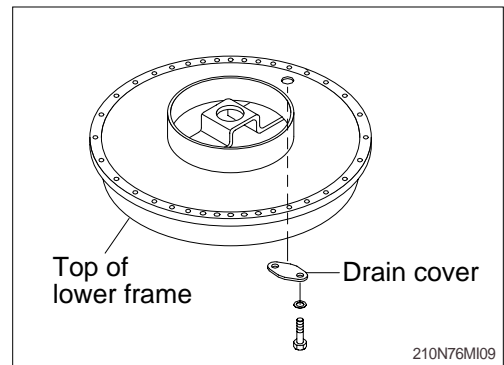

29) LUBRICATE RCV LEVER

- Remove the bellows and with a grease gun grease the joint part(A) and sliding parts(B).

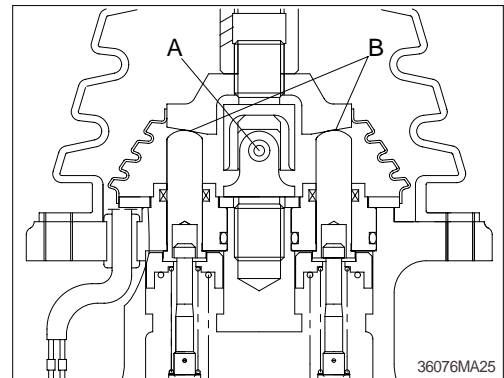

30) LUBRICATE

(1) Drive shaft

- Front drive shaft : 3 point
- Rear drive shaft : 3 point

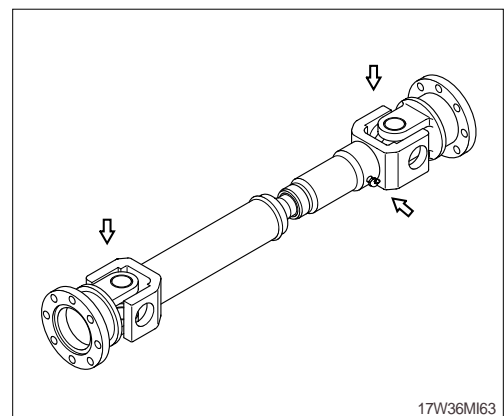

(2) Axle

Front axle : 2 point

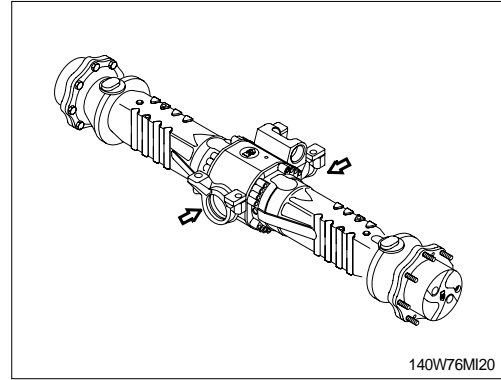

(3) Steering link : 4 point

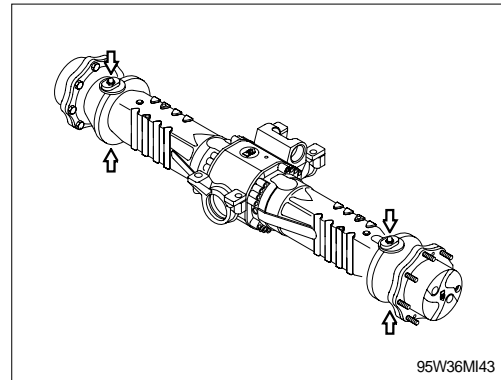

(4) Outrigger : 8 point

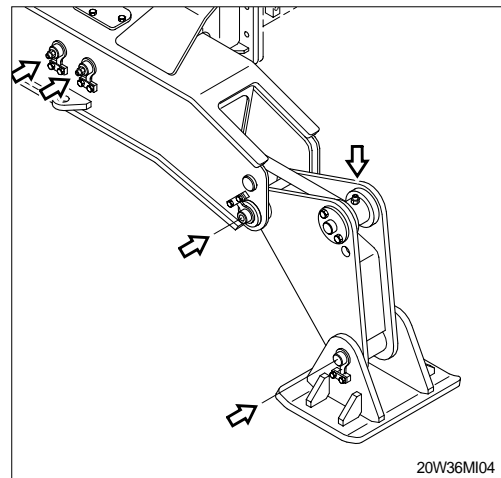

(5) Dozer blade : 12 point

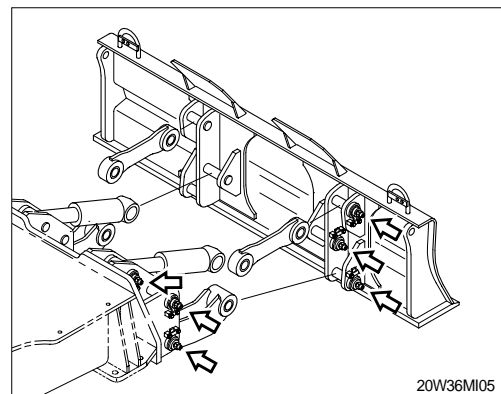

31) TIRE

(1) Air pressure

It is important to keep air pressure properly for maximizing tire life. Both excessive and insufficient air pressure of tires should be avoided not to damage tires.

Specification : 7.0kg/cm²(100psi)

(2) Handling of tire

Removal of tire

- Lift the main body until a tire separate from the ground, and place the block under front and rear axle.
- Loosen wheel nut with torque wrench and remove tire.

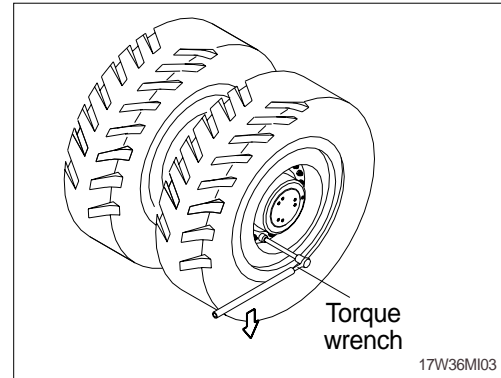

Installation of tire

- Coat some grease on wheel stud and nut screw.
- Install the tires and tighten a nut slightly and get down a tire on the ground, and then tighten the torque in the order as figure.

-Tightening torque :

$62.0 \pm 3.0 \text{kgf} \cdot \text{m} (448 \pm 21.7 \text{lb} \cdot \text{ft})$

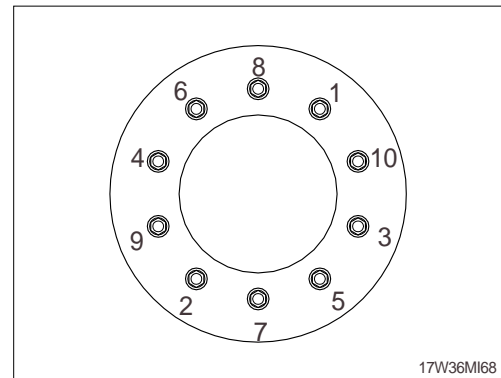

Position change of tire

- Tire is worn out differently part by part according to installing position, so change position regularly as figure.

Keep air pressure at standard.

Use same pattern of groove and same maker's tire.

Always check the tire before operation.

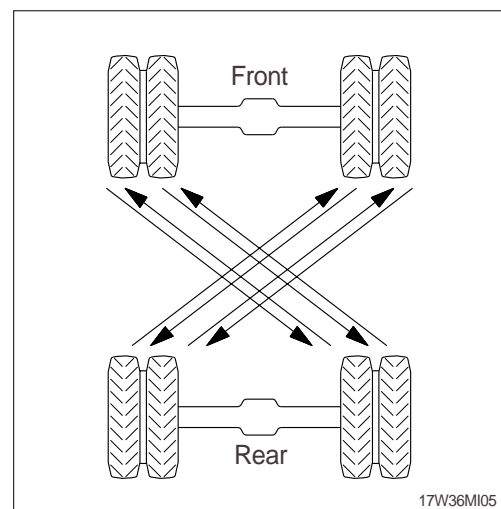

32) CHECK PLANETARY GEAR OIL LEVEL

- (1) Move the machine to flat ground.
- (2) Remove the plug and check the oil amount.
Set the oil level check line of planetary gear in parallel to the around.
- (3) If the oil level is below the plug hole, supply oil through a plug hole.
- (4) After checking, install plug.

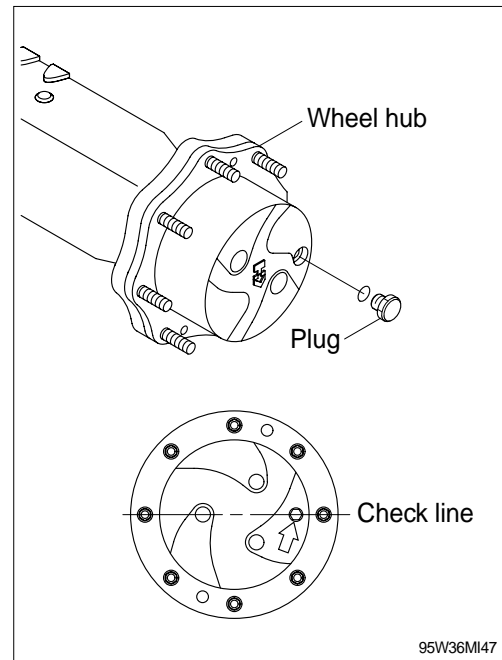

33) CHECK AND SUPPLYING AXLE OIL

- (1) Move the machine to flat ground.
- (2) Open the axle air breather to relieve internal air pressure.

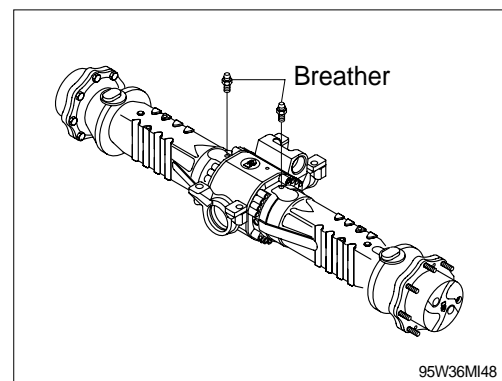

- (3) Remove the plug and check the oil amount.
If the oil level is at the hole of the plug, it is normal.
- (4) If the oil level is below the plug hole, supply oil through a plug hole.

▲ When checking the oil level, press the service brake.

▲ As the machine is hot after operation, wait until the oil temperature has dropped.

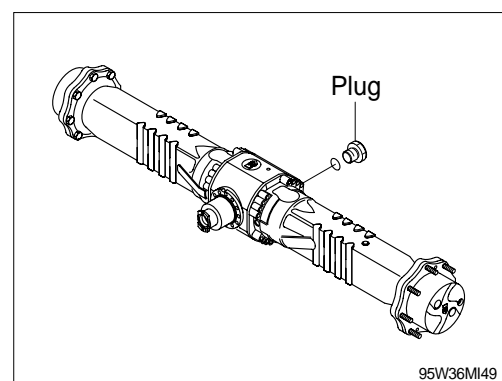

34) CHANGE THE AXLE OIL

- (1) Place a drain box under drain plug to catch oil.
- (2) Remove the air breather to relieve internal pressure.
- (3) **Drain oil the differential gear**
Remove the filling plug and remove the drain plug to drain oil off.
Wash drain plug and install it.

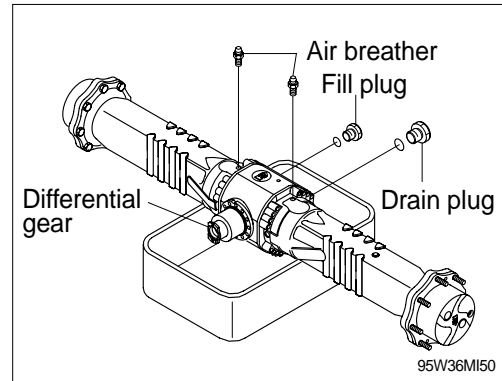

- (4) **Drain oil planetary gear**
Drain oil by removing drain plug.
The drain plug should be facing the ground.

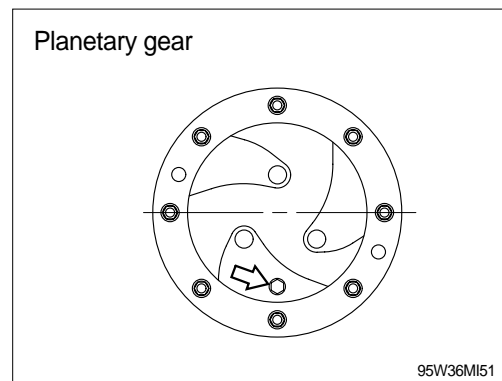

- (5) Supply oil into the differential gear and the planetary gear.
· Oil amount

Description	Capacity
Front axle differential gear	7.75 (2.0U.S. gal)
Rear axle differential gear	8.4 (2.2U.S. gal)
Planetary gear case(each)	1.2 (0.32U.S. gal)

- (6) Supply oil until it overflows from the oil filler, then install the plug.
▲ As the machine is hot after operation, wait until the temperature has dropped.
If a work requires frequent use of brake, replace it earlier than normal change interval.

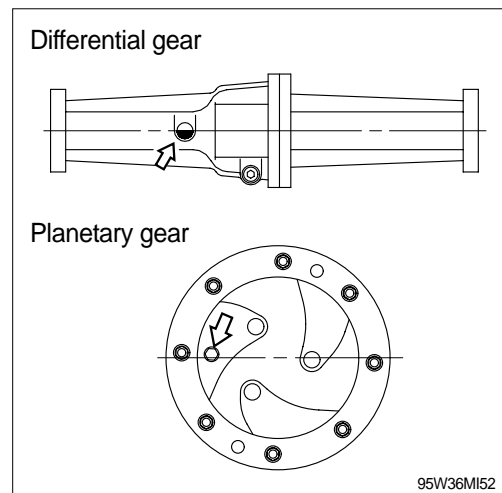

35) CLEANING AXLE BREATHER

- (1) Remove dust or debris around the breather.
- (2) Remove the breather and wash it with cleaning oil.

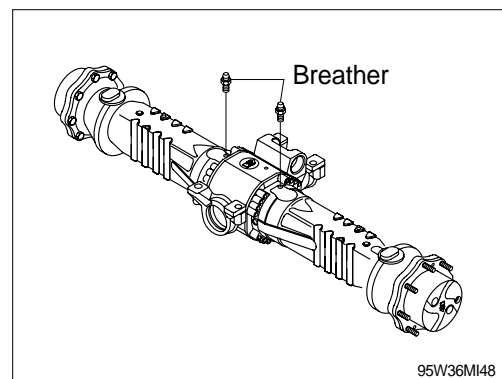

36) CHECK AND SUPPLYING TRANSMISSION OIL

- (1) Move the machine to flat ground.
- (2) Open the transmission air breather to relieve internal air pressure.
- (3) Remove the plug and check the oil amount.
If the oil level is at the hole of the plug, it is normal.
- (4) If the oil level is below the plug hole, supply oil through a plug hole.

▲ As the machine is hot after operation, wait until the oil temperature has dropped.

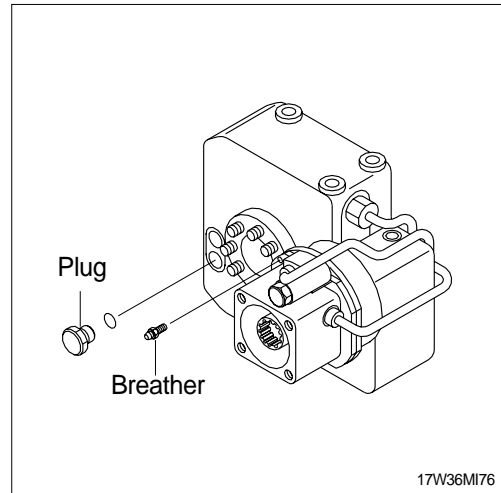

37) CHANGE THE TRANSMISSION OIL

- (1) Place a drain box under drain plug to catch oil.
- (2) Open transmission air breather to relieve internal air pressure.
- (3) Remove the drain plug to drain oil.
- (4) Wash drain plug and install it.
- (5) Supply oil into the transmission case.
· Oil amount : 3.2 (0.85U.S. gal)

▲ As the machine is hot after operation, wait until the temperature has dropped.

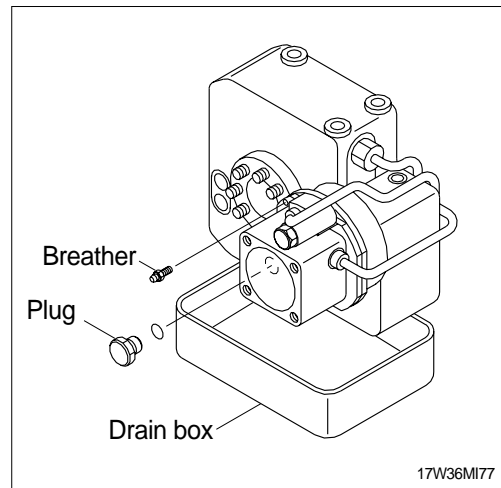

38) CLEANING TRANSMISSION AIR BREATHER

- (1) Remove dust or debris around the air breather.
- (2) Remove the air breather and wash it with cleaning oil.

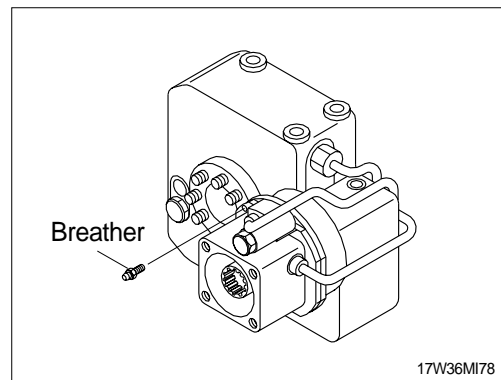

39) REPLACEMENT OF BUCKET

⚠ When knocking the pin in with a hammer, metal particles may fly and cause serious injury, particularly if they get into your eyes. When carrying out this operation, always wear goggles, helmet, gloves, and other protective equipment.

When the bucket is removed, place it in a stable condition.

When performing joint work, make sure signals to each other and work carefully for safety's sake.

(1) Lower the bucket on the ground as the picture shown in the right.

(2) Lock the safety lever to the LOCK position and stop the engine.

(3) Remove the stopper bolts(1) and nuts(2), then remove pins(3, 4) and remove the bucket.

When removing the pins, place the bucket so that it is in light contact with the ground.

If the bucket is lowered strongly to the ground, the resistance will be increased and it will be difficult to remove the pins.

After remove the pins, make sure that they do not become contaminated with sand or mud and that the seals of bushing on both sides do not become damaged.

(4) Align the arm with holes(A) and the link with holes(B), then coat with grease and install pins(3, 4)

When installing the bucket, the O-rings are easily damaged, so fit the O-rings on the boss of the bucket as shown in the picture.

After knocking the pin, move the O-ring down to the regular groove.

(5) Install the stopper bolt(1) and nuts(2) for each pin, then grease the pin.

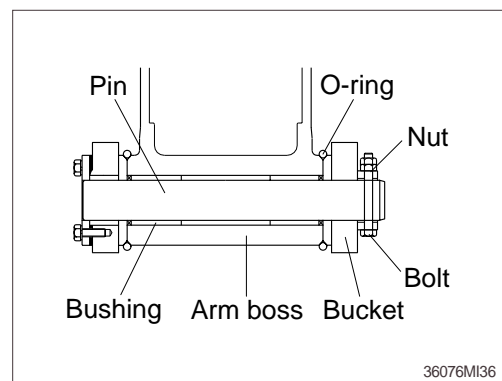
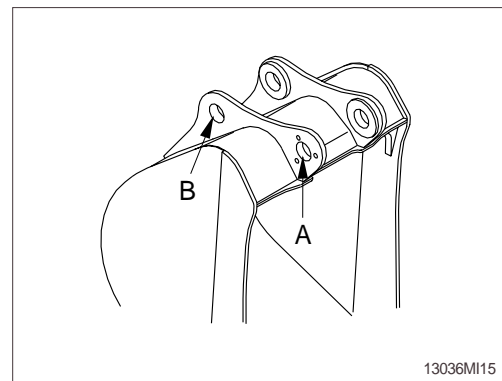
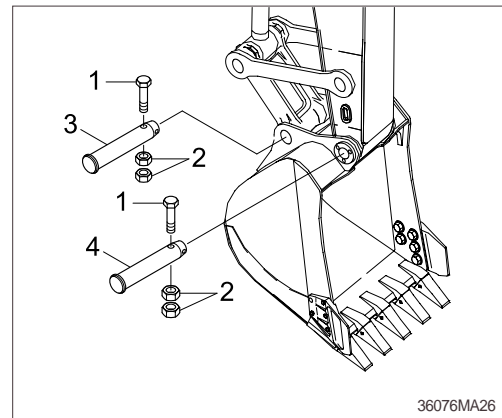
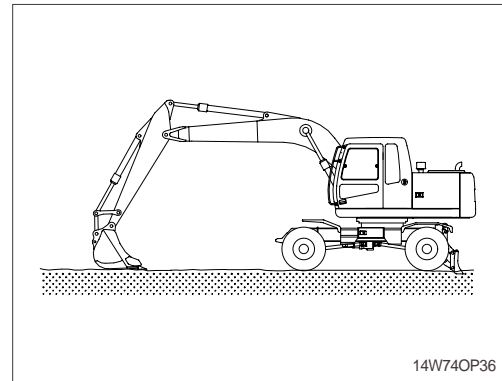

40) REPLACEMENT OF BUCKET TOOTH

(1) Timing of replacement

Check wearing condition as shown in the illustration and replace tooth tip before adapter starts to wear.

If excessive use, tooth adapter has worn out, replacement may become impossible.

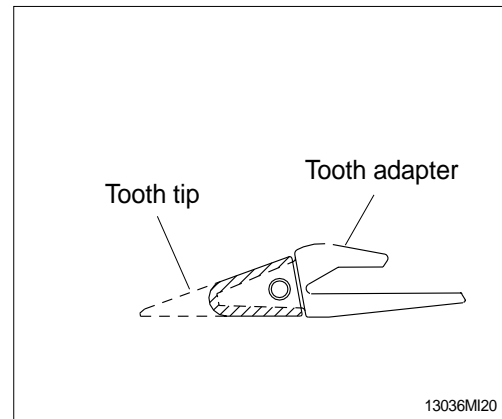

(2) Instructions for replacement

Pull out pin by striking pin with punch or hammer, avoiding damage to locking washer.

Remove dust and mud from surface of tooth adapter by using knife.

Place locking washer in its proper place, and fit tooth tip to adapter.

Insert pin until locking washer is positioned at tooth pin groove.

▲ Personal injury can result from bucket falling.

▲ Block the bucket before changing tooth tips or side cutters.

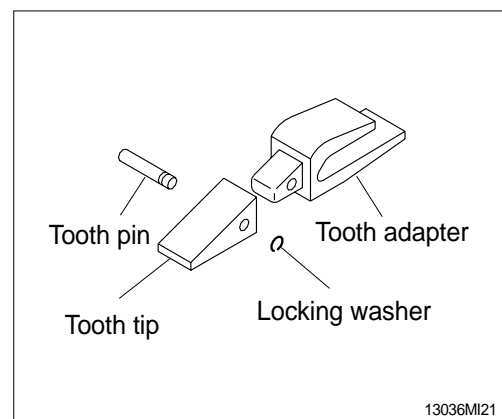

41) ADJUSTMENT OF BUCKET CLEARANCE

- (1) Lower the bucket on the ground as the picture shown in the right.
- (2) Swing to the left and keep the arm boss to be contact to the bucket left.
- (3) Lock the safety lever to the LOCK position and stop the engine.
- (4) Measure the clearance(A) between bucket and arm boss. This is the total clearance.

(5) Adjusting

Loosen bolt(2), and remove washer(3), plate(1) and shim(4).

Remove the shim equivalent value with measuring value.

Assemble the parts in the reverse order of removal.

- Tightening torque : $29.6 \pm 3.2 \text{kgf} \cdot \text{m}$
($214.0 \pm 23.1 \text{lbf} \cdot \text{ft}$)
- Normal clearance : $0.5 \sim 1.0 \text{mm}$
($0.02 \sim 0.04 \text{in}$)

If the bucket is not adjusted correctly, noise and vibration created during operation, and damaged O-ring, pin and bushing quickly.

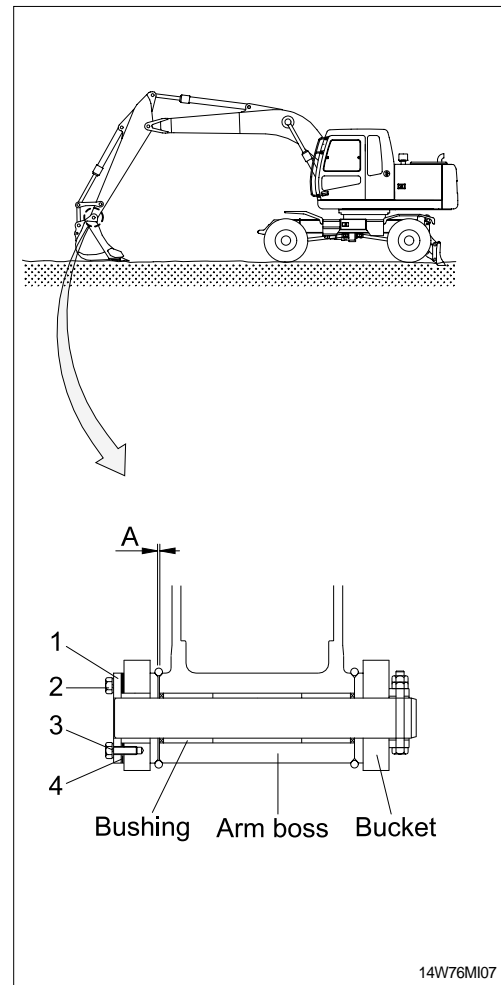

42) LUBRICATE PIN AND BUSHING

(1) Lubricate to each pin of working device

Lubricate the grease to the grease nipple according to the lubricating interval.

No.	Description	Qty
1	Lubrication manifold at boom	5
2	Boom cylinder pin	2
3	Boom and arm connection pin	1
4	Arm cylinder pin(Rod side)	1
5	Bucket cylinder pin(Head, rod)	2
	Bucket link(Control rod)	3
	Arm and bucket connection pin	1
	Arm and control link connection pin	1
6	Boom rear center bearing	1

Shorten lubricating interval when working in the water or dusty place.

(2) Dust seals are mounted on the rotating part of working device to extend the lubricating interval.

Mount the lip to be faced outside when replace the dust seal.

If it is assembled in wrong direction, it will cause fast wear of pin and bushing, and create noise and vibration during operation. Assemble the seal same direction with picture and use with plastic hammer when replace.

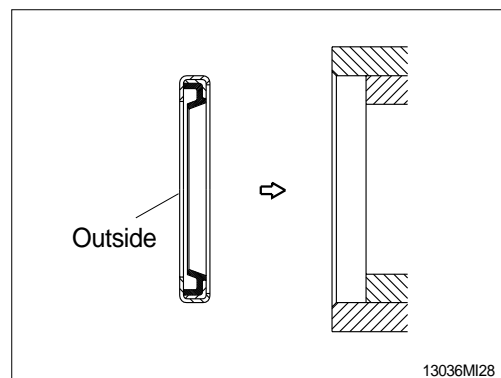
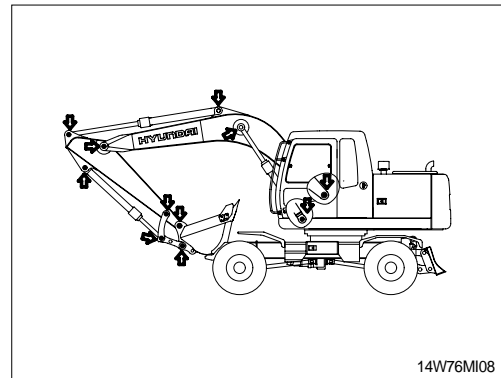
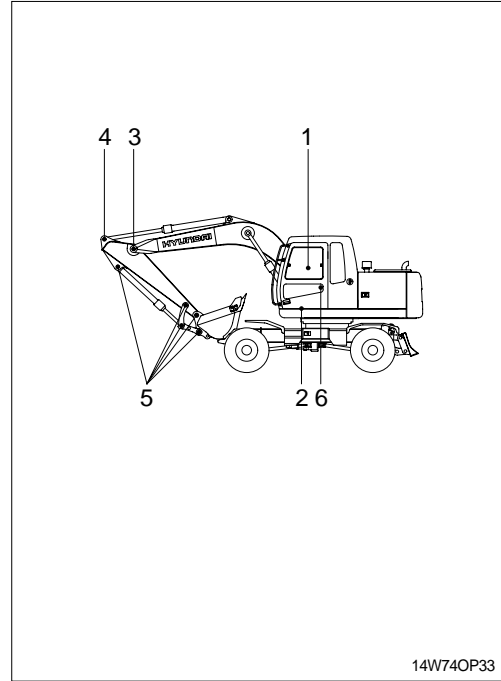

7. ELECTRICAL SYSTEM

1) WIRING, GAUGES

Check regularly and repair loose or malfunctioning gauges when found.

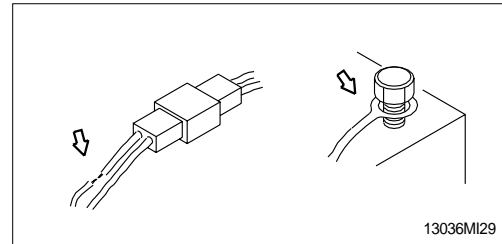

2) BATTERY

(1) Check and repair

Check the electrolyte level and fill with distilled water to the prescribed level as necessary.

Wash the terminal with hot water if it is contaminated, and apply grease to the terminals after washing.

⚠ Do not stain clothes or skin with electrolyte as it is acid.

Be careful not to get the electrolyte in eyes.

Wash with clean water and go to the doctor if it enters the eyes.

Remove the fire and spark around battery.

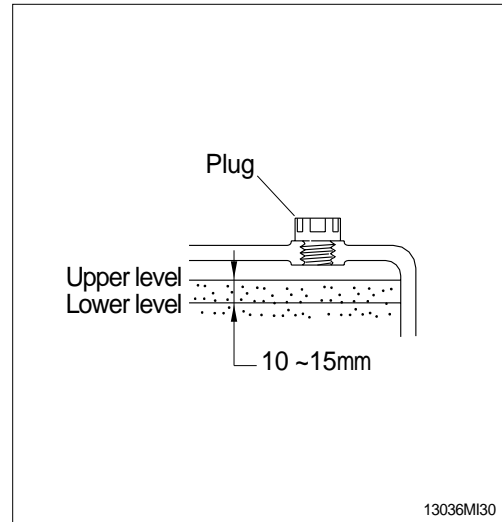

(2) Specific gravity of battery

Judge the charging rate of battery by the specific gravity. The specific gravity changes by the ambient temperature.

Check the charging rate by referring to the chart below.

Temperature	20°C (68°F)	10°C (50°F)	-10°C (14°F)
Charging rate			
100%	1.26	1.27	1.28
90%	1.24	1.25	1.26
80%	1.22	1.23	1.24
75%	1.21	1.22	1.23

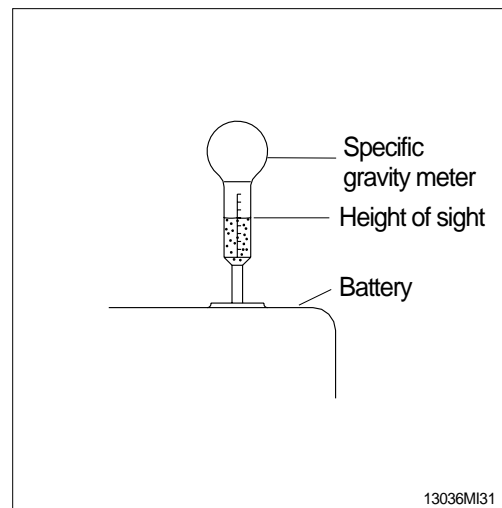

(3) Method of removing the battery cable

Remove the cable from the ground connection first (⊖ terminal side) and reconnect it last when reassembling.

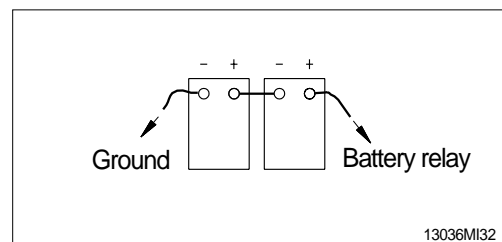

3) STARTING THE ENGINE WITH A BOOSTER CABLE

Keep following order when you are going to start engine using booster cable.

(1) Connection of booster cable

Use the same capacity of battery for starting.

Make sure that the starting switches of the normal machine and trouble machine are both at the OFF position.

Connect the red terminal of booster cable to the battery (+) terminal between exhausted and new battery.

Connect the black terminal of the booster cable between new battery (-) terminal and chassis of trouble machine.

Keep firmly all connection, the spark will be caused when connecting finally.

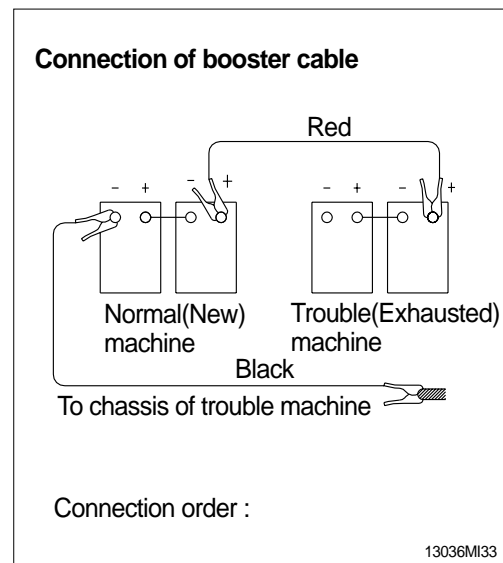

(2) Starting the engine

Starting the engine of the normal machine and keep it to run at high idle.

Start engine of the trouble machine with starting switch.

If you can not start it by one time, restart the engine after 2 minutes.

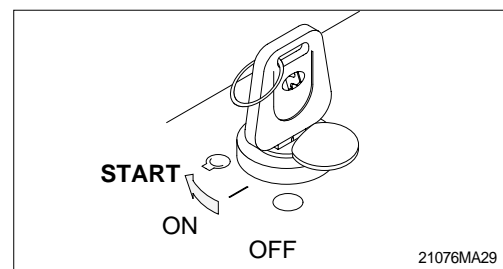

(3) Taking off the booster cable

Take off the booster cable(black).

Take off the booster cable(red) connected to the (+) terminal.

Run engine with high idle until charging the exhausted battery by alternator, fully.

▲ Explosive gas is generated while using the battery or charging it. Keep away flame and be careful not to cause the spark. Charge the battery in the well ventilated place.

Place the machine on the earth or concrete.

Avoid charging the machine on the steel plate.

Do not connect (+) terminal and (-) terminal when connecting booster cable because it will be shorted.

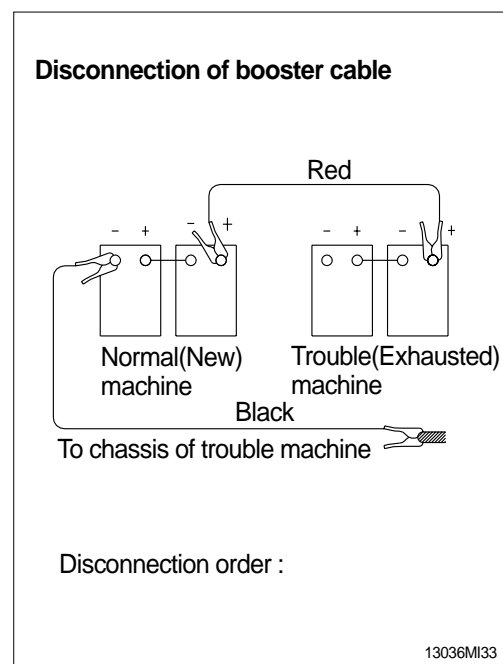

(4) Welding repair

Before start to welding, follow the below procedure.

- ① Shut off the engine and remove the starting switch.
 - ② Disconnect ground cable from battery by master switch.
 - ③ Before carrying out any electric welding on the machine, the battery cables should be disconnected and the connectors pulled out of the electronic control units(CPU, cluster etc).
 - ④ Connect the earth(ground) lead of the welding equipment as close to the welding point as possible.
- ※ Do not weld or flame cut on pipes or tubes that contain flammable fluids. Clean them thoroughly with nonflammable solvent before welding or flame cutting on them.
- ▲ Do not attempt to welding work before carry out the above.
If not, it will caused serious damage at electric CAPO system.

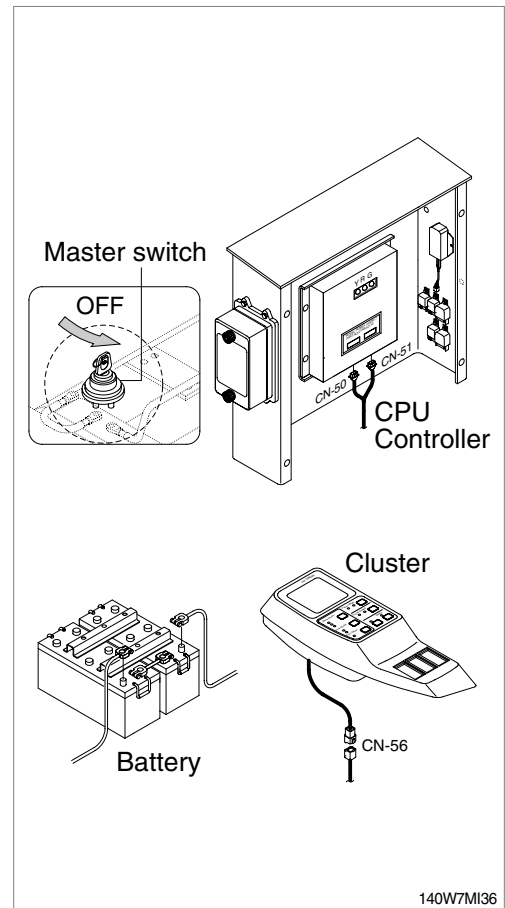

8. AIR CONDITIONER AND HEATER

1) CLEAN AND REPLACE OF OUTER FILTER

Always stop the engine before servicing.

- (1) Move seat and console box to arrow direction using the adjust lever.

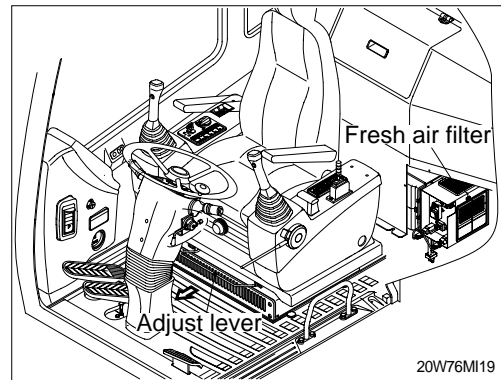

- (1) Remove the outer filter.

When installing a filter, be careful not to change the filter direction.

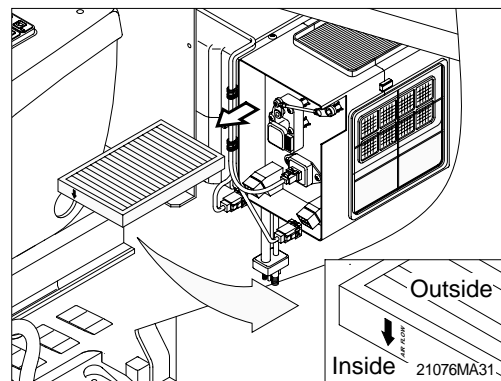

- (3) Clean the filter using a pressurized air (Below 2kgf/cm^2 , 28psi).

△ **When using pressurized air, be sure to wear safety glasses.**

- (4) Inspect the filter after cleaning. If it is damaged or badly contaminated, use a new filter.

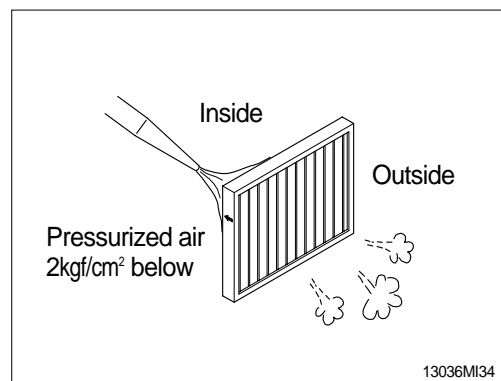

2) CLEAN AND REPLACE OF INNER FILTER

Always stop the engine before servicing.

- (1) Move seat and console box to arrow direction using the adjust lever.

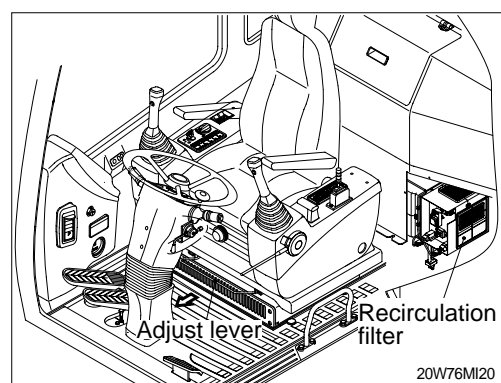

(2) Remove recirculation filter.

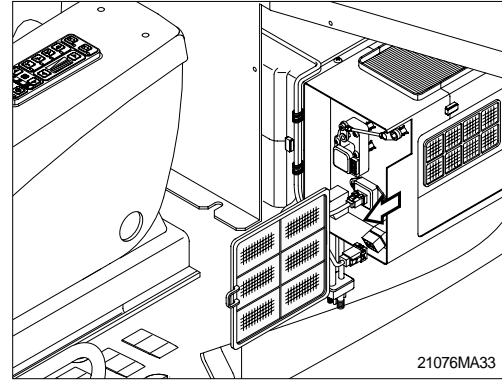

(3) Clean the recirculation filter using a pressurized air (Below 2kgf/cm^2 , 28psi) or washing with water.

△ **When using pressurized air, be sure to wear safety glasses.**

Dry off after washing with water.

(4) Inspect the filter after cleaning. If it is damaged or badly contaminated, use a new filter.

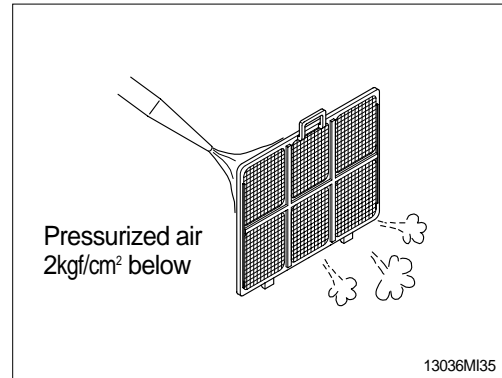

3) PRECAUTIONS FOR USING AIR CONDITIONER

(1) When using the air conditioner for a long time, open the window once every one hour.

(2) Be careful not to overcool the cab.

(3) The cab is properly cooled if the operator feels cool when entering there from outside (About 5°C lower than the outside temperature).

(4) When cooling, change air occasionally.

4) CHECK DURING SEASON

Ask the service center for replenishment of refrigerant or other maintenance service so that the cooling performance is not damaged.

5) CHECK DURING OFF-SEASON

Operate the air conditioner 2 or 3 times a month (Each for a few minutes) to avoid loss of oil film in the compressor.