

5. TRANSPORTATION

1. ROAD TRAVELING

As this machine can run at the maximum speed of 32km/h, it is not necessary to transport the machine on trailer in a short distance.

But the transportation by the trailer is convenient in a long distance.

If it is necessary to travel on a road, observe the followings.

- 1) Comply with regulations regarding this machine for the sake of safety.
- 2) Perform daily inspection before starting the machine.
- 3) Cross the bridge after checking that it will safely support the machine weight. If the bridge can not support, a detour must be prepared or the bridge must be reinforced.
- 4) When traveling for a long distance, stop every hour to allow tires and other components to cool down and check any abnormality.
- 5) Drive with the bucket empty.

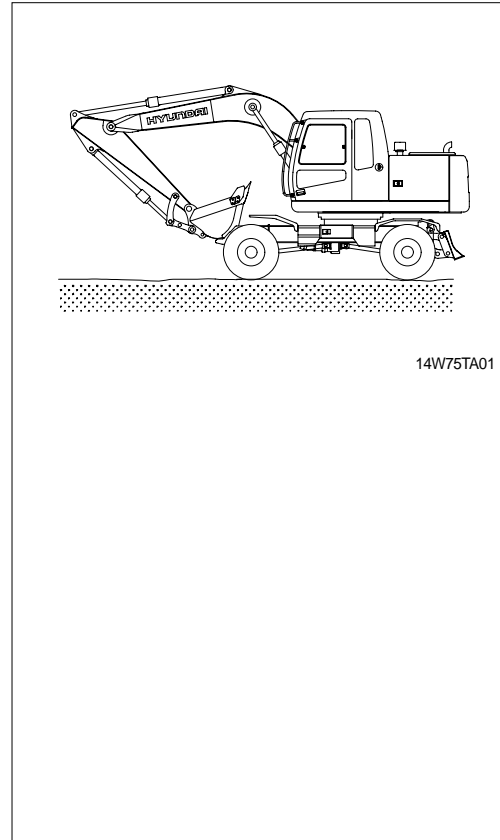

14W75TA01

2. PREPARATION FOR TRANSPORTATION

- 1) When transporting the machine, observe the various road rules, road transportation vehicle laws and vehicle limit ordinances, etc.
- 2) Select proper trailer after confirming the weight and dimension from the chapter 2, specification.
- 3) Check the whole route such as the road width, the height of bridge and limit of weight and etc., which will be passed.
- 4) Get the permission from the related authority if necessary.
- 5) Prepare suitable capacity of trailer to support the machine.

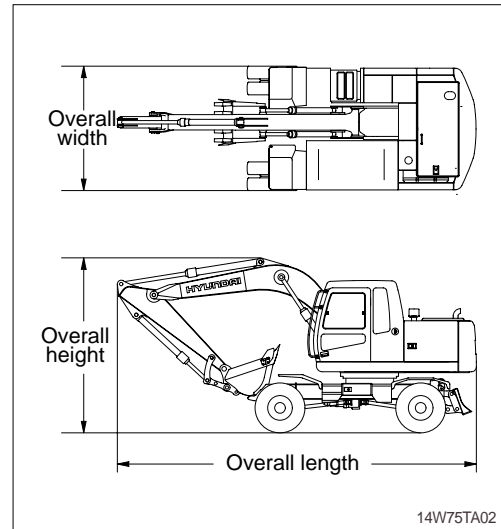

- 6) Prepare gangplank for safe loading referring to the below table and illustration.

A	B
1.0	3.65 ~ 3.85
1.1	4.00 ~ 4.25
1.2	4.35 ~ 4.60
1.3	4.75 ~ 5.00
1.4	5.10 ~ 5.40
1.5	5.50 ~ 5.75

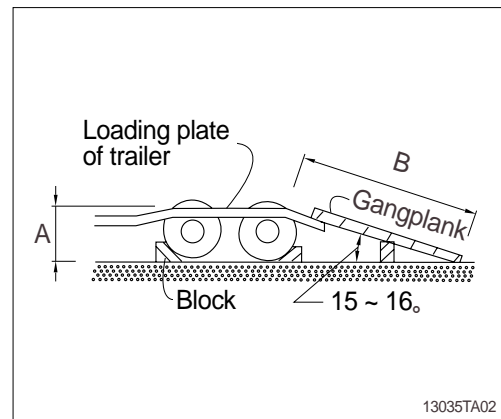

3. DIMENSION AND WEIGHT

1) ROBEX 140W-7

(1) Base machine

Mark	Description	Unit	Specification
L	Length	mm(ft-in)	4395(14' 5")
H	Height	mm(ft-in)	3140(10' 4")
W	Width	mm(ft-in)	2500(8' 2")
Wt	Weight	kg(lb)	11120(24515)

1900kg(4190lb) counterweight.

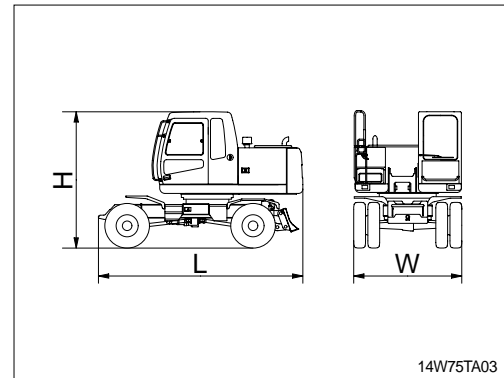

(2) Boom assembly

Mark	Description	Unit	Specification
L	Length	mm(ft-in)	4760(15' 7")
H	Height	mm(ft-in)	1340(4' 5")
W	Width	mm(ft-in)	520(1' 8")
Wt	Weight	kg(lb)	1020(2250)

4.6m(15' 1") boom with arm cylinder(Included piping and pins).

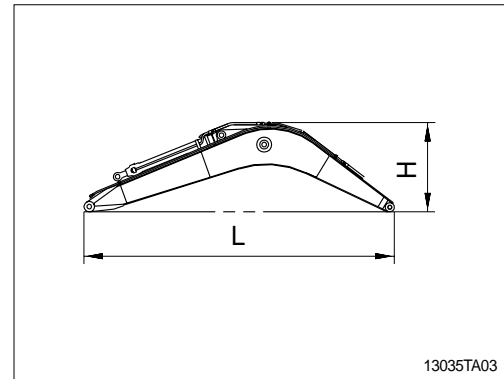

(3) Arm assembly

Mark	Description	Unit	Specification
L	Length	mm(ft-in)	2880(9' 5")
H	Height	mm(ft-in)	810(2' 8")
W	Width	mm(ft-in)	380(1' 3")
Wt	Weight	kg(lb)	570(1260)

2.10m(6'11") arm with bucket cylinder(Included linkage and pins).

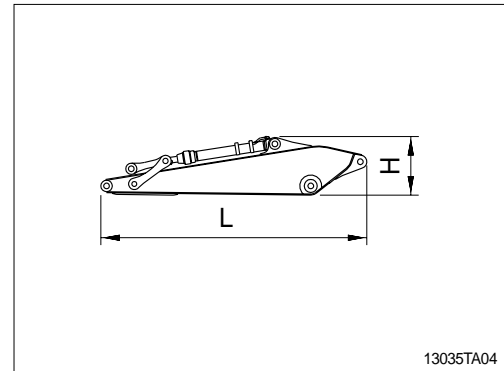

(4) Bucket assembly

Mark	Description	Unit	Specification
L	Length	mm(ft-in)	1400(4' 7")
H	Height	mm(ft-in)	800(2' 7")
W	Width	mm(ft-in)	1130(3' 8")
Wt	Weight	kg(lb)	480(1060)

0.58m³(0.76yd³) SAE heaped bucket(Included tooth and side cutters).

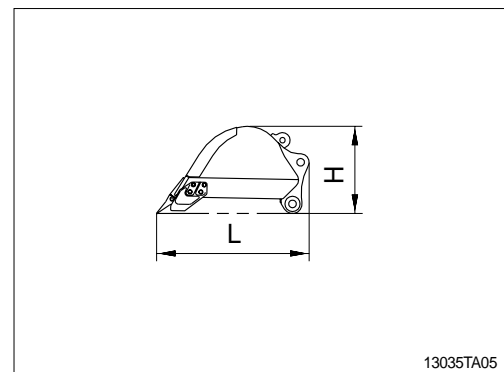

(5) Boom cylinder

Mark	Description	Unit	Specification
L	Length	mm(ft-in)	1760(5' 9")
H	Height	mm(ft-in)	210(0' 8")
W	Width	mm(ft-in)	310(1' 0")
Wt	Weight(2EA)	kg(lb)	260(570)

Included piping.

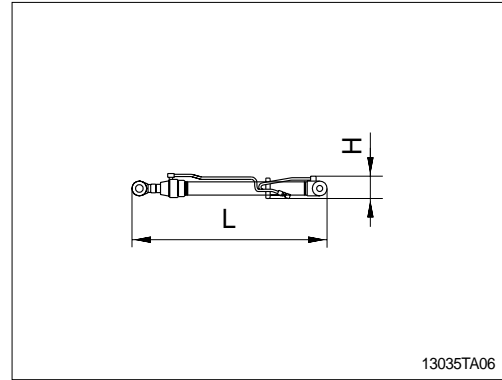

(6) Cab assembly

Mark	Description	Unit	Specification
L	Length	mm(ft-in)	1962(6' 4")
H	Height	mm(ft-in)	1676(5' 5")
W	Width	mm(ft-in)	1288(4' 2")
Wt	Weight	kg(lb)	310(680)

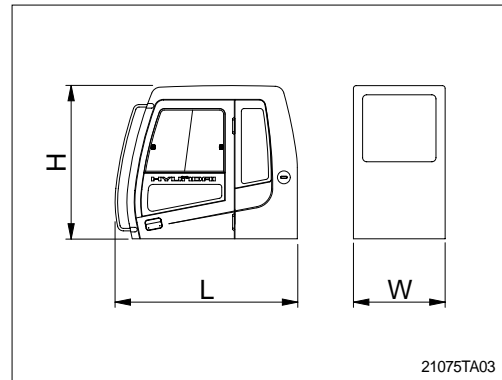

(7) Counterweight

Mark	Description	Unit	Specification
L	Length	mm(ft-in)	2475(8' 1")
H	Height	mm(ft-in)	1050(3' 5")
W	Width	mm(ft-in)	450(1' 6")
Wt	Weight	kg(lb)	1900(4190)

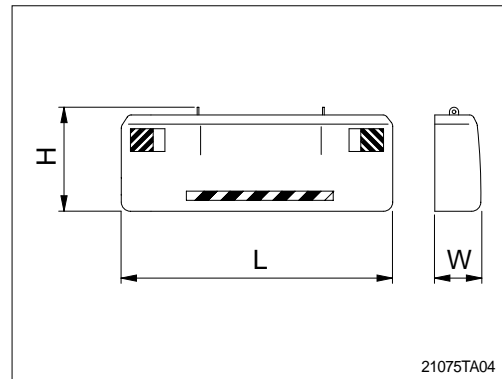

4. LOADING THE MACHINE

- 1) Load and unload the machine on a flat ground.
- 2) Use the gangplank with sufficient length, width, thickness and gradient.
- 3) Place block tires of the truck and the trailer not to move the trailer.
- 4) Place the swing lock device to the **LOCK** position before fixing the machine at the bed of trailer and confirm if the machine parallels the bed of trailer.
- 5) Drive straight and depress the acceleration pedal slowly on the gangplank with the two speed switch positioned as low speed.

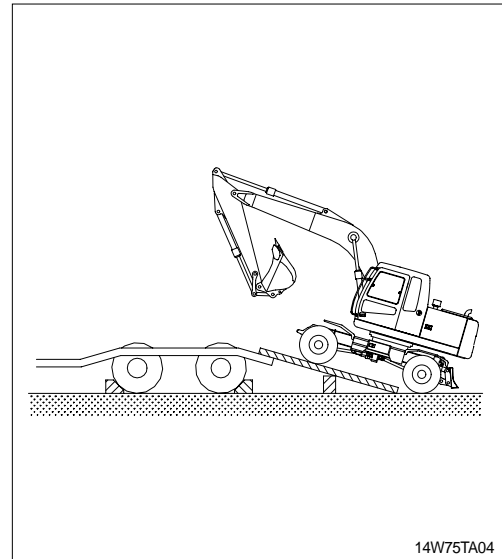

- 6) Do the following after loading the machine to the trailer.
 - (1) Stop loading when the machine is located horizontally with the rear wheel of trailer.

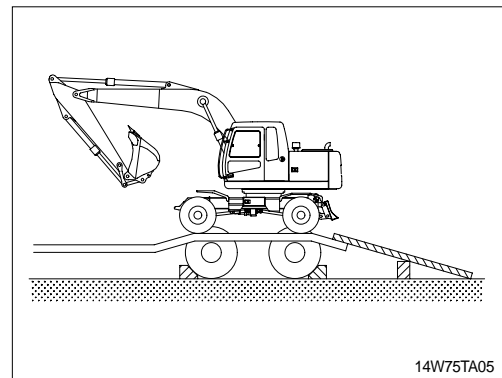

- (2) Place the swing lock device to the **LOCK** position after the swing the machine 180 degree.

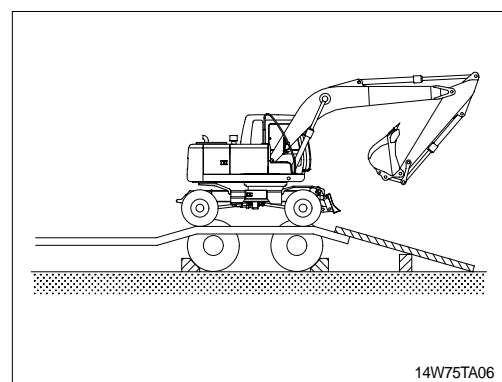

(3) Lower the working equipment gently after the location is determined.

Place rectangular timber under the bucket cylinder to prevent the damage of it during transportation.

⚠ Be sure to keep the travel speed switch on the low speed while loading and unloading the machine.

⚠ Avoid using the working equipment for loading and unloading since it will be very dangerous.

⚠ Do not operate any other device when loading.

⚠ Be careful on the boundary place of loading plate or trailer as the balance of machine will abruptly be changed on the point.

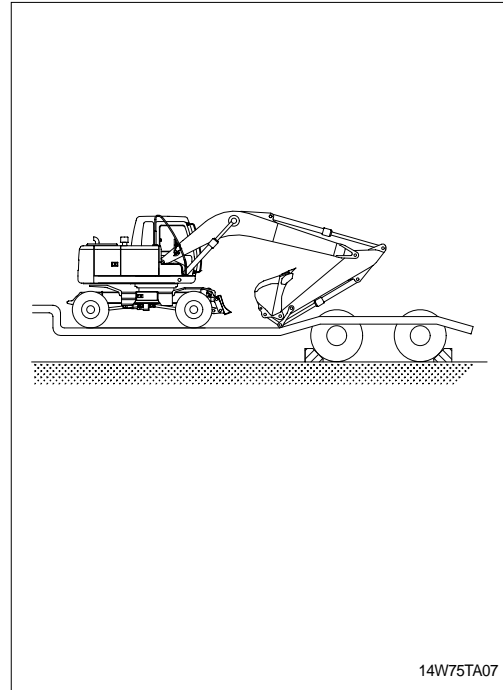

5. FIXING THE MACHINE

- 1) Place the swing lock device on the LOCK position.
- 2) Place the parking switch to the parking position.
- 3) Keep the safety lever on the SAFETY position.
- 4) Turn OFF all the switches and remove the key.

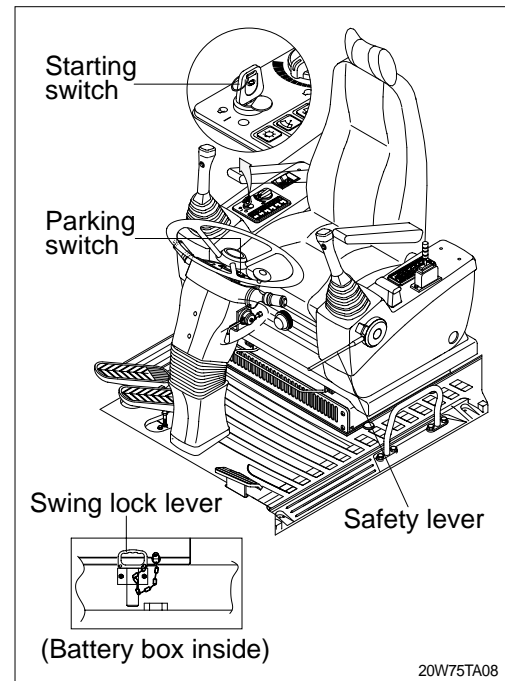

- 5) Secure all locks.

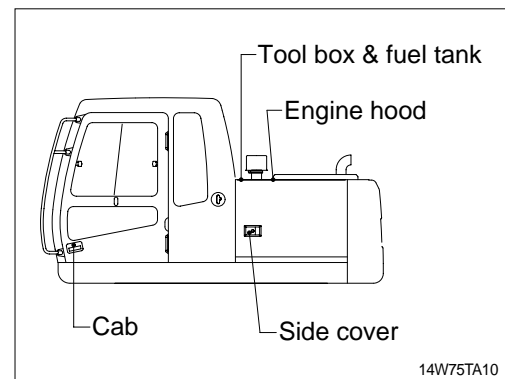

- 6) Place timber underneath of the tires and fix firmly with wire rope to prevent the machine from moving forward, backward, right or left.

