

3. LOADING THE MACHINE

- 1) Load and unload the machine on a flat ground.
- 2) Use the gangplank with sufficient length, width, thickness and gradient.
- 3) Place the swing lock lever to the LOCK position before fixing the machine at the bed of trailer and confirm if the machine parallels the bed of trailer. Keep the travel motor in the rear when loading and in the front when unloading.

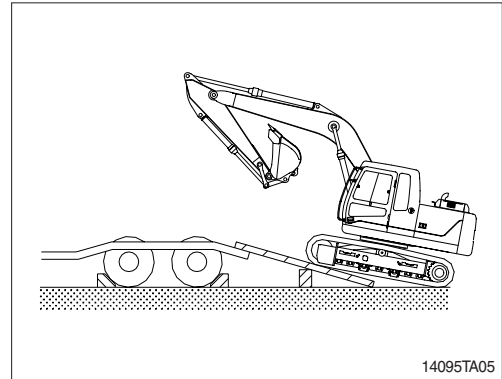

- 4) Do the following after loading the machine to the trailer.
 - (1) Stop loading when the machine is located horizontally with the rear wheel of trailer.

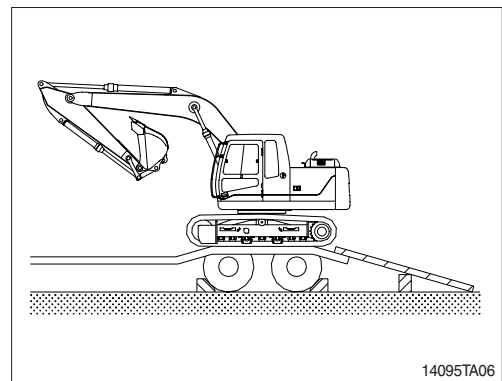

- (2) Place the swing lock lever to the LOCK position after the swing the machine 180 degree.

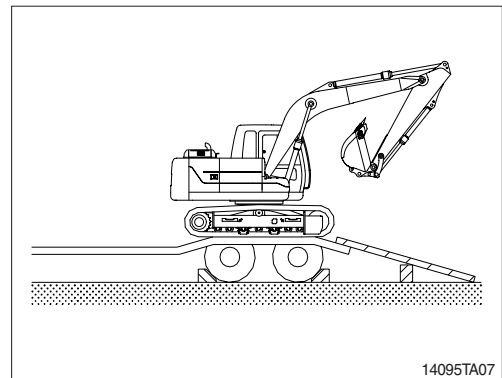

- (3) Lower the working equipment gently after the location is determined.
- ※ **Place rectangular timber under the bucket cylinder to prevent the damage of it during transportation.**
- ▲ **Be sure to keep the travel speed switch on the LOW (turtle mark) while loading and unloading the machine.**
 - ▲ **Avoid using the working equipment for loading and unloading since it will be very dangerous.**
 - ▲ **Do not operate any other device when loading.**
 - ▲ **Be careful on the boundary place of loading plate or trailer as the balance of machine will abruptly be changed on the point.**

