

4. LEVERS AND PEDALS

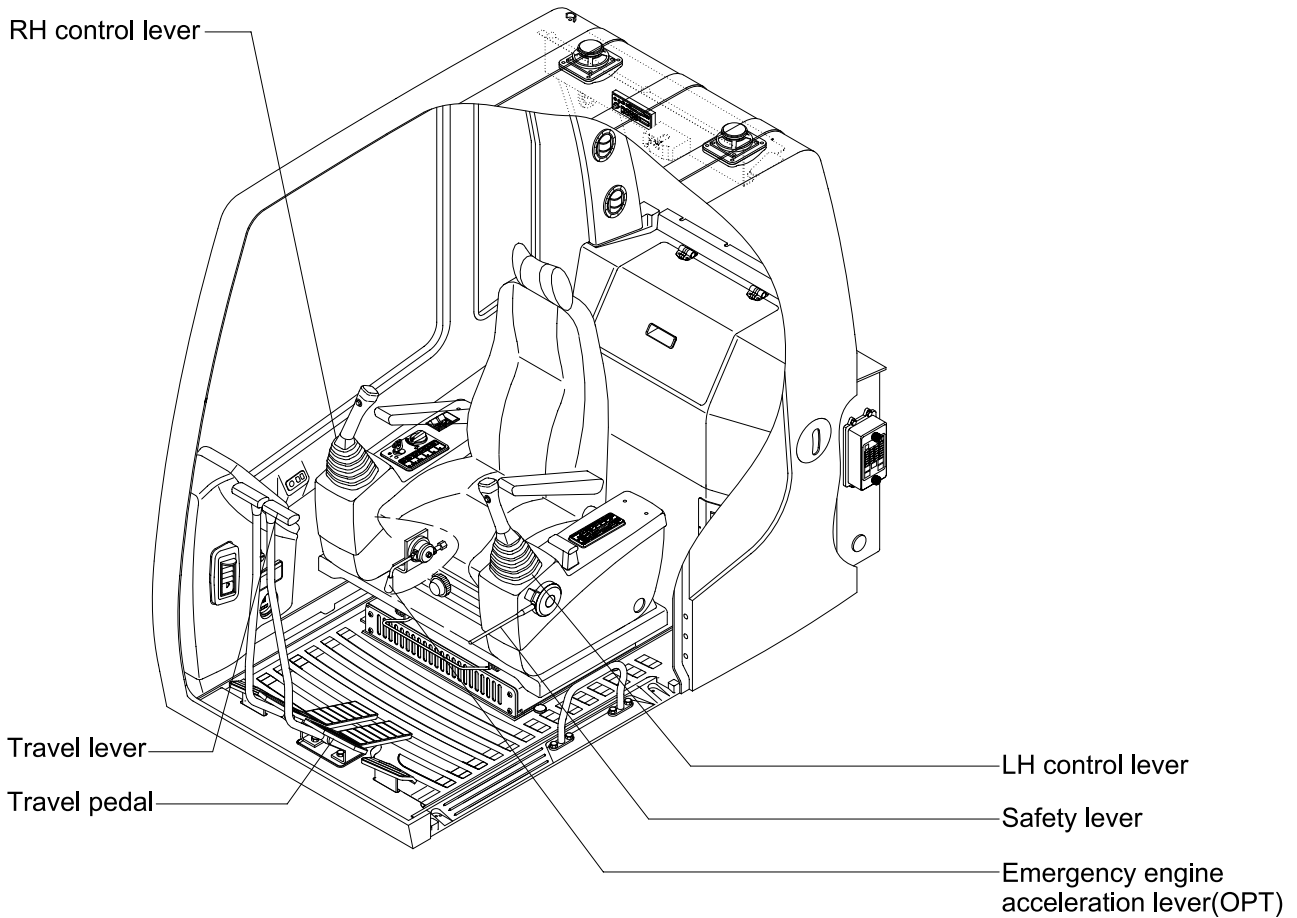

32073CD41

1) LH CONTROL LEVER

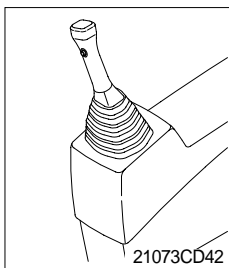

- (1) This joystick is used to control the swing and the arm.
- (2) Refer to **operation of working device** in chapter 4 for details.

2) RH CONTROL LEVER

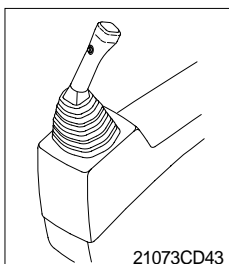

- (1) This joystick is used to control the boom and the bucket.
- (2) Refer to **operation of working device** in chapter 4 for details.

3) ENGINE ACCELERATION LEVER FOR EMERGENCY(Option)

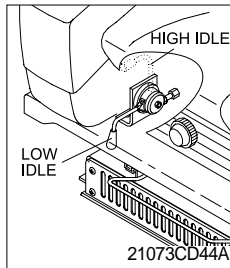

- (1) This lever is used to increase or reduce the rotation speed of engine when the abnormality is occurred in CPU controller .
Connect the resistor with frame harness.
Refer to the 3-26 page for connection of prolix resistor.
- (2) Move the lever up to increase engine RPM.
Move the lever down to decrease engine RPM.
When stopping the engine, turn the key to OFF and move the acceleration lever completely down.

METHOD OF CONNECTING EMERGENCY ENGINE ACCELERATION LEVER(Option)

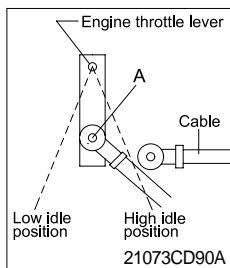

- (1) Open engine hood and disconnect rod from throttle lever at a A point.
- (2) Connect emergency engine acceleration cable to throttle lever at A point.

4) EMERGENCY ENGINE STARTING CONNECTOR

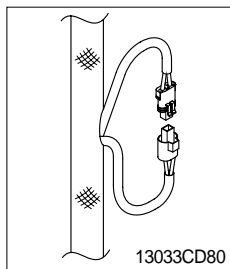

- (1) If the CPU controller is removed, the engine does not start.
- (2) Before starting the engine, connect the connector CN-92 A with B.

Do not connect these connectors when the CPU is not removed.

5) SAFETY LEVER

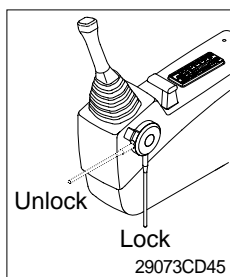

- (1) All control levers and pedals are disabled from operation by pulling the lever to lock position as shown.
Be sure to keep the lever to LOCK position when leaving from operator's seat.
- (2) By pushing lever to UNLOCK position, machine is operational.
Do not use the safety lever for handle when getting on or off the machine.

6) TRAVEL LEVER

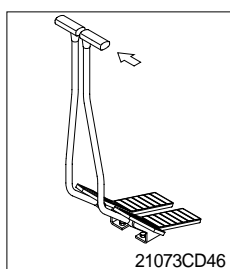

- (1) This lever is mounted on travel pedal and used for traveling by hand.
The operation principle is same as the travel pedal.
- (2) Refer to **traveling of the machine** in chapter 4 for details.

7) TRAVEL PEDAL

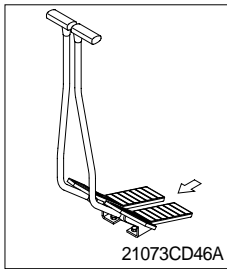

- (1) This pedal is used to move the machine forward or backward.
- (2) If left side pedal is pressed, left track will move.
If right side pedal is pressed, right track will move.
- (3) Refer to **traveling of machine** in chapter 4 for details.

8) SEAT AND CONSOLE BOX ADJUST LEVER

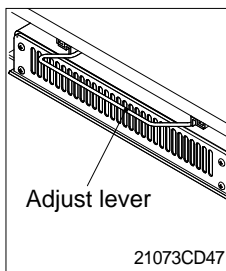

- (1) This lever is used to move the seat and console box to fit the contours of the operator's body.
- (2) Pull the lever to adjust forward or backward over 170mm(6.7").

9) DOZER CONTROL LEVER(Option)

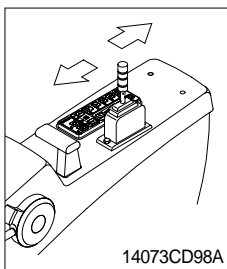

- (1) This lever is used to operate the dozer blade.
- (2) If the lever is pushed forward, the dozer blade will be going down.
And the lever is pulled back, the dozer blade will be going up.